

Noritake **itron**

VACUUM FLUORESCENT DISPLAY
MODULE
SPECIFICATION

MODEL : CU24025ECPB-W1J

SPECIFICATION NO. : DS-627-0000-01

DATE OF ISSUE : Apr. 3, 1997

R E V I S I O N : Nov. 27, 1997

PUBLISHED BY
ISE ELECTRONICS CORP. / JAPAN

This specification is subject to change without prior notice.

1. General Description

1.1 Application :

Readout of computer, micro-computer, communication terminal and automated instruments.

1.2 Construction :

Single board display module consists of 48 characters(2 x 24) VFD, one chip controller driver which has character generator ROM and RAM, DC/DC converter.

1.3 Scope

Interface level is TTL-8/4 bit parallel and the module can be connected to the CPU bus directly. +5V single power supply is required.

2. Absolute Maximum Ratings

Parameter	Symbol	Min.	Typ.	Max.	Unit	Condition
Power Supply Voltage	VCC	0	—	5.5	VDC	—
Logic Input Voltage	VI	0	—	VCC	VDC	—

3. Electrical Ratings

Conditions :Ta=25°C

Parameter	Symbol	Min.	Typ.	Max.	Unit	Condition
Logic Input Voltage	"H"	VIH	2.0	—	VCC	VDC VCC = 5.0V
	"L"	VIL	0	—	0.8	
Power supply Voltage	Vcc	4.75	5.00	5.25	VDC	—

4. Electrical Characteristics

Conditions : Ta =25°C, VCC=5.0V

Parameter	Symbol	Min.	Typ.	Max.	Unit	Condition
Logic Output Voltage	"H"	VOH	VCC-0.4	—	—	VDC IOH = -1.60mA IOL = 1.60 mA
	"L"	VOL	—	—	0.4	
Power Supply Current 1	ICC 1	—	155	225	mA	Display ON
Power Supply Current 2	ICC 2	—	2	10	mA	Display OFF

Note : ICC1 shows the current, when all dots are turned on.

Slow-start power supply may cause a failure of Power-on reset which is explained in " 8.2 Power-on reset". The power supply is recommended to be quick switch-type(quicker than 50ms).

ICC1 might be anticipated twice as usual at power on rush.

5. Optical Characteristics

Number of characters	: 48 (2 lines x 24 chars)
Matrix format	: 5 x 7 dot with underline
Display area	: 85.2 x 11.5mm (X x Y)
Character size	: 2.4 x 4.7 mm (X x Y) Underline is not included.
Character pitch	: 3.6 mm
Line pitch	: 6.1 mm
Dot size	: 0.4 x 0.5mm (X x Y)
Dot pitch	: 0.5 x 0.7mm (X x Y)
Luminance	: 350 cd/m ² (100fL) Min.
Color of illumination	: Blue-Green

6. Environmental Conditions

Operating temperature	: -40 to +85 °C
Storage temperature	: -40 to +85 °C
Operating humidity	: 20 to 80 % RH (Non condensation)
Vibration(Non operation):	10 to 55 to 10 Hz(Frequency), 1 mm(Total Amplitude) 30 Min.(Duration) X,Y,Z each direction
Shock (Non operation)	: 539 m/S ² , 10mS

7. Functional Descriptions

7.1 Instruction table

Instruction	CODE										Cycle Time	Description	
	RS	R/W	DB7	DB6	DB5	DB4	DB3	DB2	DB1	DB0			
Display clear	0	0	0	0	0	0	0	0	0	0	1	2.3 ms Max.	Clears all display and sets DD RAM address 0 in the address counter.
Cursor home	0	0	0	0	0	0	0	0	0	1	*	1*tCYC	Sets DD RAM address 0 in the address counter. Also returns the display being shifted to the original position. DD RAM contents remain unchanged.
Entry mode set	0	0	0	0	0	0	0	0	1	I/D	S	1*tCYC	Sets the cursor direction and specifies display shift. These operations are performed during writing/reading data.
Display ON/OFF control	0	0	0	0	0	0	0	1	D	C	B	1*tCYC	Sets all display ON/OFF(D), cursor ON/OFF(C), cursor blink of character position (B).
Cursor or display shift	0	0	0	0	0	0	1	S/C	R/L	*	*	1*tCYC (2*tCYC)	Shifts displayed cursor, keeping DD RAM contents.
Function set	0	0	0	0	1	IF	*	*	*	*	*	1*tCYC	Sets data length (IF).
Brightness control	1	0	*	*	*	*	*	*	*	BR1	BR0	1*tCYC	Accepts 1 byte data of just after "Function set" as brightness control data.

Instruction	CODE										Time	Description
	RS	R/W	DB7	DB6	DB5	DB4	DB3	DB2	DB1	DB0		
CG RAM address setting	0	0	0	1	ACG						1*tCYC (2*tCYC)	Sets the CG RAM address.
DD RAM address setting	0	0	1	ADD						1*tCYC (2*tCYC)	Sets the DD RAM address.	
Busy flag & address reading	0	1	BF	ACC						1*tCYC	Reads BusyFlag (BF) and address counter.	
Data writing to CG or DD RAM	1	0	Data writing						1*tCYC	Writes data into CG RAM or DD RAM.		
Data reading from CG or DD RAM	1	1	Data reading						1*tCYC	Reads data from CG RAM or DD RAM		
	I/D = 1 : Increment IF = 1 : 8-bit I/D = 0 : Decrement IF = 0 : 4-bit S = 1 : Display shift enabled BF = 1 : Busy S = 0 : Cursor shift enabled BF = 0 : Not S/C = 1 : Display shift busy S/C = 0 : Cursor move R/L = 1 : Shift to the right R/L = 0 : Shift to the left BR1, BR0 = 00: 100% 01: 75% 10: 50% 11: 25%											DD RAM: Display Data RAM CG RAM: Character Generator RAM ACG: CG RAM address ADD: DD RAM address corresponds to cursor address

Note:

* : don't care

tCYC : tCYC is read/write cycle (Min1us) of HOST SYSTEM.

() : If RAM read is a next operation, needs execution time indicated by "()".

7.2 Display Clear

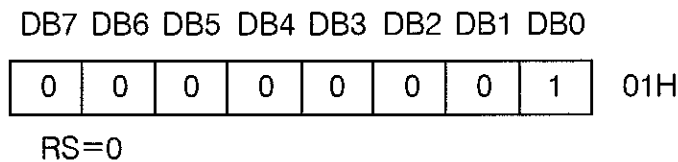

This instruction

1. Fills all locations in the display data (DD) RAM with 20H(Blank character).
2. Clears the contents of the address counter to 0H.
3. Sets the display for zero character shift.
4. Sets the address counter to point to the DD RAM.
5. If the cursor is displayed, moves the cursor to the left most character in the top line (line 1).
6. Sets the address counter to increment on each access of DD RAM or CG RAM

7.3 Cursor Home

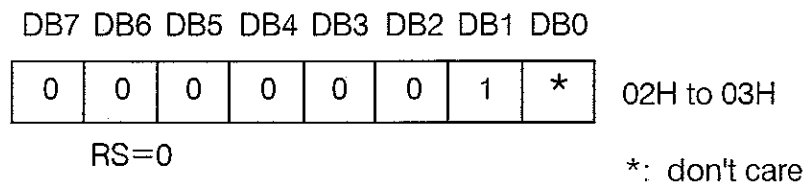

This instruction

1. Clears the contents of the address counter to 0H.
2. Sets the address counter to point to the DD RAM.
3. Sets the display for zero character shift.
4. If the cursor is displayed, moves the left most character in the top line (line 1).

7.4 Entry Mode Set

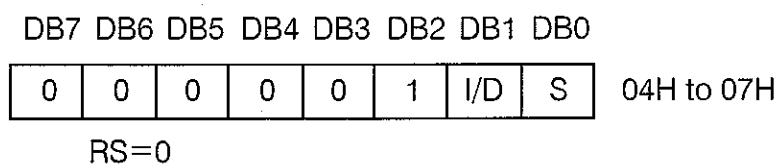

The I/D bit selects the way in which the contents of the address counter are modified after every access to DD RAM or CG RAM.

- I/D=1: The address counter is incremented.
- I/D=0: The address counter is decremented.

The S bit enables display shift, instead of cursor shift, after each write or read to the DD RAM.

- S=1: Display shift enabled.
- S=0: Cursor shift enabled.

The direction in which the display is shifted is opposite in sense to that of the cursor. For example if S=0 and I/D=1, the cursor would shift one character to the right after a CPU writes to DD RAM. However if S=1 and I/D=1, the display would

shift one character to the left and the cursor would maintain its position on the panel.

The cursor will already be shifted in the direction selected by I/D during reads of the DD RAM, irrespective of the value of S. Similarly reading and writing the CG RAM always shifts the cursor. Also both lines are shifted simultaneously

Cursor move and Display shift by the "Entry Mode Set"

I/D	S	After writing DD RAM data	After reading DD RAM data
0	0	The cursor moves one character to the left.	The cursor moves one character to the left.
1	0	The cursor moves one character to the right.	The cursor moves one character to the right.
0	1	The display shifts one character to the right without cursor's move.	The cursor moves one character to the left.
1	1	The display shifts one character to the left without cursor's move.	The cursor moves one character to the right.

7.5 Display ON/OFF

DB7	DB6	DB5	DB4	DB3	DB2	DB1	DB0	
0	0	0	0	1	D	C	B	08H to 0FH
RS=0								

This instruction controls various features of the display

The D bit turns the entire display on or off .

D=1: Display on

D=0: Display off

Note: When display is turned off, power converter also inhibited and reduce a power consumption.

The C bit turns the cursor on or off.

C=1: Cursor on

C=0: Cursor off

The B bit enables blinking of the character the cursor coincides with.

B=1: Blinking on

B=0: Blinking off

Blinking is achieved by alternating between a normal and all on display of a character. The cursor blinks with a period of about 1.1 Hz and DUTY 50%.

7.6 Cursor/Display Shift

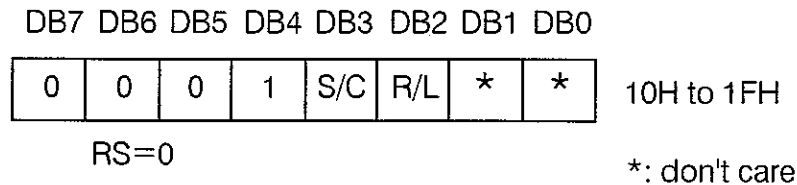

This instruction shifts the display and/or moves the cursor, on character to the left or right, regardless of DD RAM write/read.

The S/C bit selects movement of the cursor or movement of both the cursor and the display.

S/C=1: Shift both cursor and display

S/C=0: Shift cursor only

The R/L bit selects left ward or right ward movement of the display and/or cursor

R/L=1: Shift one character right

R/L=0: Shift one character left

Cursor move and Display shift by the "Cursor/Display Shift"

S/C	R/L	Cursor shift	Display shift
0	0	Move one character to the left	No shift
0	1	Move one character to the right	No shift
1	0	Shift one character to left with display	Shift one character to the left
1	1	Shift one character to right with display	Shift one character to the right

7.7 Function Set

This command sets width of data bus line by itself, and sets screen brightness by following one byte data.

7.7.1 Function Set Command

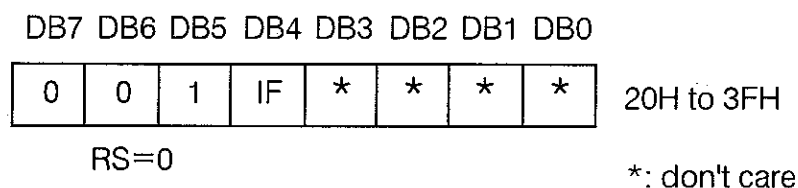

This instruction initializes the system, and must be the first instruction executed after power-on. The IF bit selects between an 8-bit or a 4-bit bus width interface.

IF=1: 8-bit CPU interface using DB7 to DB0

IF=0: 4-bit CPU interface using DB7 to DB4

7.7.2 Brightness Control

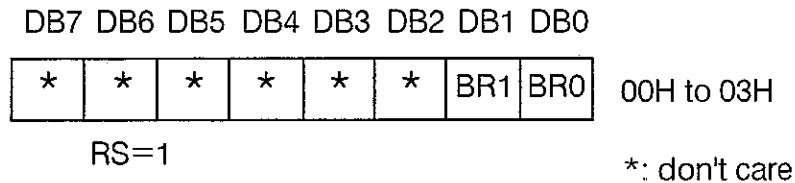

One byte data (RS = 1) which follows the " Function Set Command " is considered as brightness data. When a command (RS=0) is written after the " Function Set Command ", the brightness control function is not initiated. Screen brightness is as follows;

BR1	BR0	Brightness
0	0	100 % (Default)
0	1	75 %
1	0	50 %
1	1	25 %

7.8 Set CG RAM Address

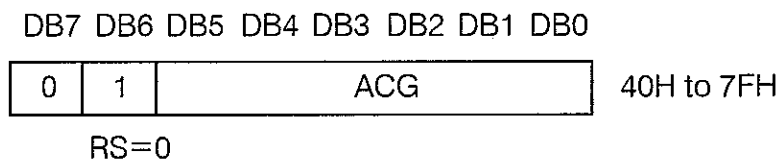

This instruction

1. Loads a new 6-bit address into the address counter.
2. Sets the address counter to address CG RAM.

Once "Set CG RAM Address" has been executed, the contents of the address counter will be automatically modified after every access of CG RAM, as determined by the "7.4 Entry Mode Set" instruction. The active width of the address counter, when it is addressing CG RAM, is 6-bit so the counter will wrap around to 00H from 3FH if more than 64 bytes of data are written to CG RAM

7.9 Set DD RAM Address

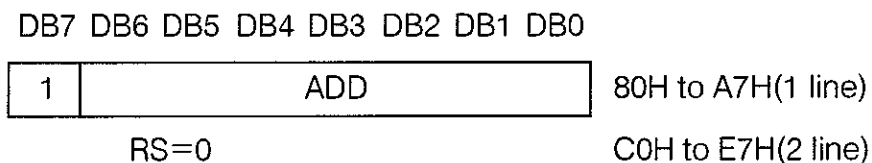

This instruction

1. Loads a new 7-bit address into the address counter.
2. Sets the address counter to point to the DD RAM.

Once the "Set DD RAM Address" instruction has been executed, the contents of the

address counter will be automatically modified after each access of DD RAM, as selected by the "7.4 Entry Mode Set" instruction.

Valid DDRAM Address Ranges

	Number of Characters	ADR
1st line	40	00H to 27H
2nd line	40	40H to 67H

7.10 Write Data

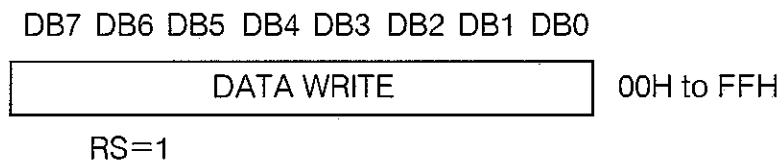

This instruction writes the data in DB7 to DB0 into either the CG RAM or the DD RAM. The RAM space (CG or DD), and the address in that space, that is accessed depends on whether a "Set CG RAM Address" or a "Set DD RAM Address" instruction was last executed, and on the parameters of that instruction. The contents of the address counter will be automatically modified after each "Write Data", as determined by the "7.4 Entry Mode Set". When data is written to the CG RAM, the DB7, DB6 and DB5 bits are not displayed as characters.

7.11 Read Data

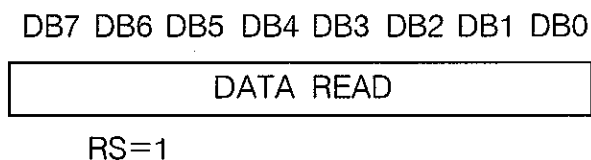

This instruction reads data from either CG RAM or DD RAM, depending on the type of "Set RAM Address" instructions last sent. The address in that space depends on the "Set RAM Address" instructions parameters. Immediately before executing "Read Data", "Set CG RAM Address" or "Set DD RAM Address" must be executed. The contents of the address counter are modified after each "Read Data", as determined by the "7.4 Entry Mode Set". Display shift is not executed, as described at the "7.4 Entry Mode Set".

7.12 Read Busy Flag/Address Counter

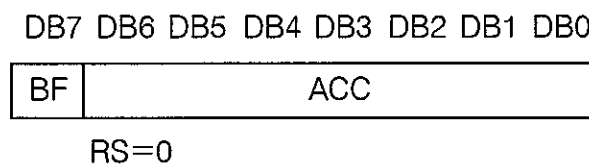

Reading the instruction register yields the current value of the address counter and the busy flag. This instruction must be executed prior to any other instructions. ACC, the

address counter value, will point to a location in either CG RAM or DD RAM, depending on the type of "Set RAM Address" instruction last sent.

In "Busy Flag Check" immediately after executing "Write Data" instruction, a valid address counter value can be ready as soon as BF goes low. The BF bit shows the status of the busy flag.

BF = 1 : The display module is busy.

BF = 0 : The display module is ready for next instruction

8 Other features

8.1 CG RAM

The display module has CG RAM of 320 bit = (5x8 bit /char) x 8 chars which is for user definable character fonts. The character fonts consists of 5 x 7 dots with underline. The number 1 ~ 36 corresponds to character fonts.

Character code	CG RAM address						CG RAM data (character pattern)							
	DB5	DB4	DB3	DB2	DB1	DB0	DB7	DB6	DB5	DB4	DB3	DB2	DB1	DB0
00H or (08H)	0	0	0	0	0	0	*	*	*	1	2	3	4	5
	0	0	0	0	0	1	*	*	*	6	7	8	9	10
	0	0	0	0	1	0	*	*	*	11	12	13	14	15
	0	0	0	0	1	1	*	*	*	16	17	18	19	20
	0	0	0	1	0	0	*	*	*	21	22	23	24	25
	0	0	0	1	0	1	*	*	*	26	27	28	29	30
	0	0	0	1	1	0	*	*	*	31	32	33	34	35
	0	0	0	1	1	1	*	*	*	36	0	0	0	0
01H or (09H)	0	0	1	0	0	0	*	*	*	1	2	3	4	5
	0	0	1	0	0	1	*	*	*	6	7	8	9	10
	0	0	1	0	1	0	*	*	*	11	12	13	14	15
	0	0	1	0	1	1	*	*	*	16	17	18	19	20
	0	0	1	1	0	0	*	*	*	21	22	23	24	25
	0	0	1	1	0	1	*	*	*	26	27	28	29	30
	0	0	1	1	1	0	*	*	*	31	32	33	34	35
	0	0	1	1	1	1	*	*	*	36	0	0	0	0

REMARKS ; "*" : Don't care "0": Turned off "1": Turned on.
Dot assignment

1	2	3	4	5
6	7	8	9	10
11	12	13	14	15
16	17	18	19	20
21	22	23	24	25
26	27	28	29	30
31	32	33	34	35
36				

Dot 36 is an under line.

8.2 Power-on reset

The module is initialized at power-on reset

The status are as follows;

1. Display clear

Fills the DD RAM with 20Hex (Space code).

During executing of " Display Clear" (Max 2.3msec), the busy flag(BF) is "1".

2. Clears the address counter to 0H.

Sets the address counter to point the DD RAM.

3. Display ON/OFF

D=0: Display OFF

C=0: Cursor OFF

B=0: Blink OFF

4. Entry Mode Set

I/D =1: Increment(+1)

S=0: No display shift

5. Function Set

IF=1: 8-bit interface

6. Brightness Control

BR0=BR1=0 : 100%

• Remarks

There is a possibility that reset doesn't work by slow-start power supply.

Therefore the initializing by commands is needed.

8.3 CPU interface

The display module is capable to communicate some different type of bus systems such as i80 or M68 ,8-bit or 4-bit data

8.3.1 Select CPU

The module is able to connected to bus of i80 type or M68 type CPU, by setting jumper.

8.3.2 4-Bit CPU interface

If 4-bit interface is used, the 8-bit instruction are written nibble by nibble: the high-order nibble being written first, followed by low-order nibble. It is not necessary to check the busy flag between writing separate nibbles of individual instructions.

See " 7.7.1 Function Set Command " for more information.

8.4 Test Mode

Self test functions built into the display module. The test mode is initiated by connecting 2 and 3 pin of 3pin connector(CN2) and power up.

In the test mode ,checker patterns are displayed on all character position.

In the future,there is a possibility to remove a 3 pin connector (CN2).

8.5 Jumper

Some jumper are prepared on the PCB board, to set operating mode of the display module. A soldering iron is required to short jumper.

The jumper "RES" is used to reset the display module.You can reset the module by shorting the jumper "RES" for some interval which is longer than 10us.

The following figure shows the location of each jumper.

Location

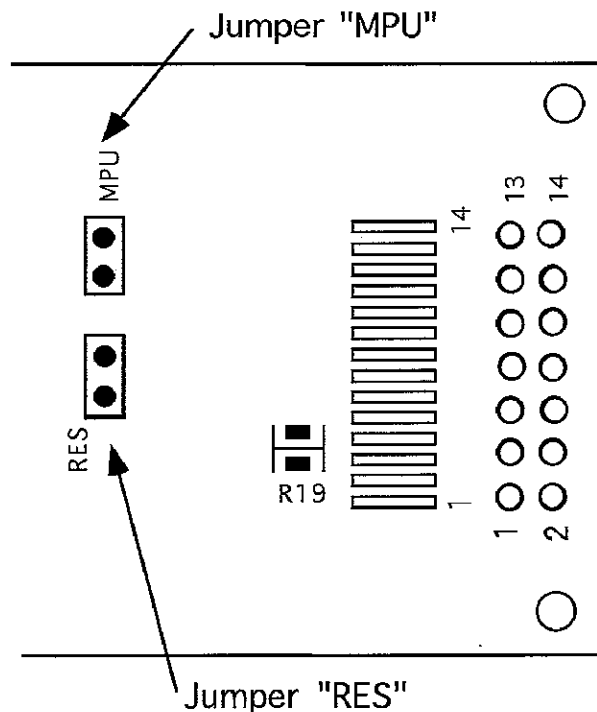

The following table shows the function of jumper "MPU".

MPU	CPU bus mode	Control signals
open	M68 type	E, R, \overline{W}
short	i80 type	$\overline{RD}, \overline{WR}$

When "R19" is short, the third hole of 14 through holes is for reset input.
Reset input signal is active when it is low.

The following table shows the function of "R19".

R19	third hole of 14 through holes
open	No connection
short	$\overline{\text{RESET}}$

The jumper resistor "R19" is open at factory.

9 Character Font

	D7	0	0	0	0	0	0	0	0	1	1	1	1	1	1	1	1
	D6	0	0	0	0	1	1	1	1	0	0	0	0	1	1	1	1
	D5	0	0	1	1	0	0	1	1	0	0	1	1	0	0	1	1
	D4	0	1	0	1	0	1	0	1	0	1	0	1	0	1	0	1
32-0 0000		0	1	2	3	4	5	6	7	8	9	A	B	C	D	E	F
0000 0				0	a	P	\	P	Δ	F		-	9	ε	o	P	
0001 1			!	1	A	Q	a	4	Δ	æ	μ	7	†	4	Δ	9	
0010 2			"	2	B	R	b	r	Δ	E	Γ	イ	ツ	×	B	θ	
0011 3			#	3	C	S	c	s	Δ	R	┘	ウ	テ	E	ε	∞	
0100 4			\$	4	D	T	d	t	Δ	#	\	I	ト	†	M	Ω	
0101 5			%	5	E	U	e	u	E	o	•	†	†	1	ε	Ü	
0110 6			&	6	F	V	f	v	Ü	+	7	カ	ニ	ε	P	Σ	
0111 7			'	7	G	W	g	w	o	◊	7	†	7	7	9	π	
1000 8			(8	H	X	h	x	θ	1	4	ウ	ホ	リ	フ	X	
1001 9)	9	I	Y	i	y	φ	9	◊	7	J	ll	"	y	
1010 A			*	:	J	Z	j	z	Ü	Δ	ε	コ	ン	レ	J	≠	
1011 B			+	;	K	L	k	l	◊	Δ	*	サ	ヒ	ロ	"	≠	
1100 C			,	<	L	¥	l	l	\	Δ	+	ヨ	フ	フ	φ	≠	
1101 D			-	=	M	I	m	i	n	>	≠	4	ユ	ズ	レ	ト	÷
1110 E			.	>	N	^	n	+	+	↑	ε	ト	ホ	"	ñ		
1111 F			/	?	O	_	o	+	ε	↓	ウ	リ	マ	"	ö		

Character Table 0
[CG57103]

Note: Font number 00~07Hex (08~0FHex) is UDF.

10. Timing

10.1 CPU bus write timing (i80 type)

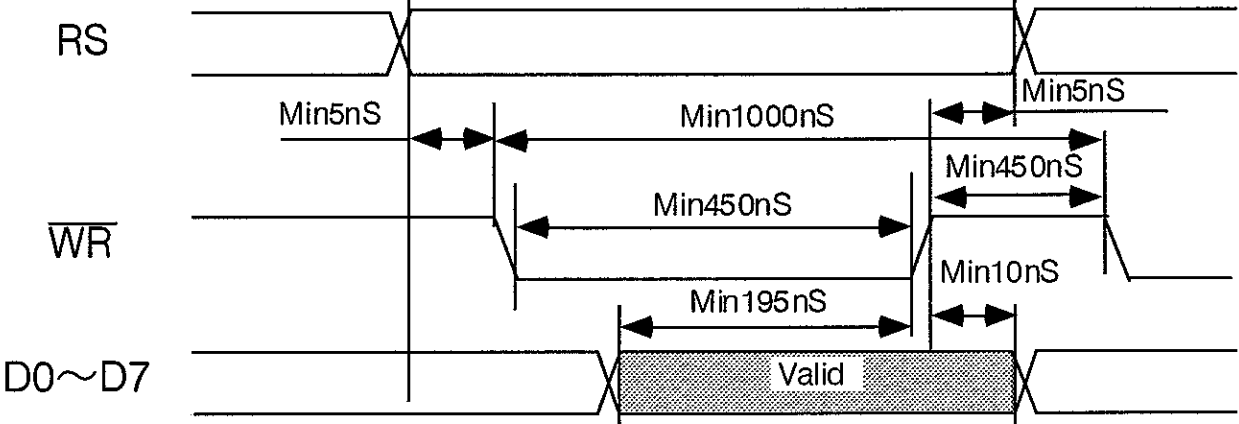

10.2 CPU bus read timing (i80 type)

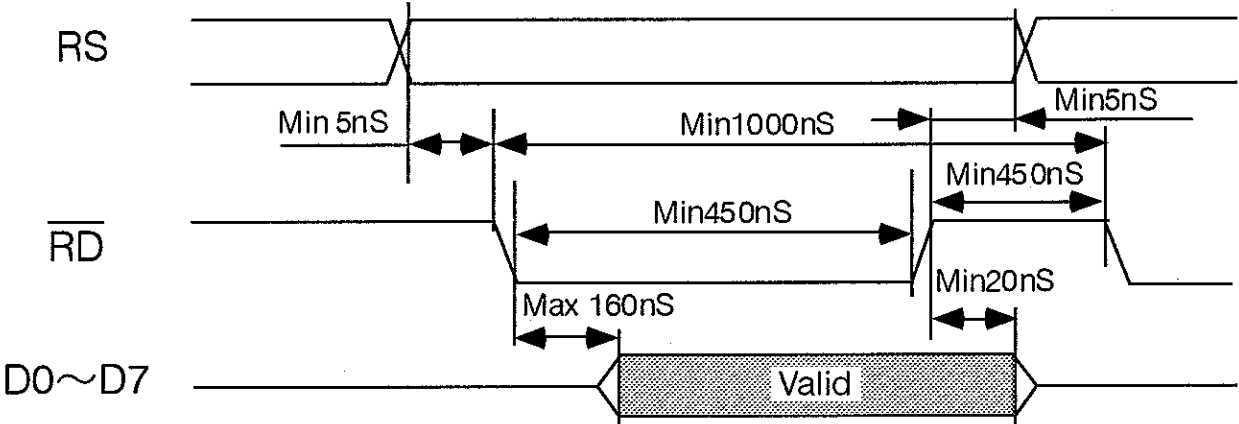

10.3 CPU bus write timing (M68 type)

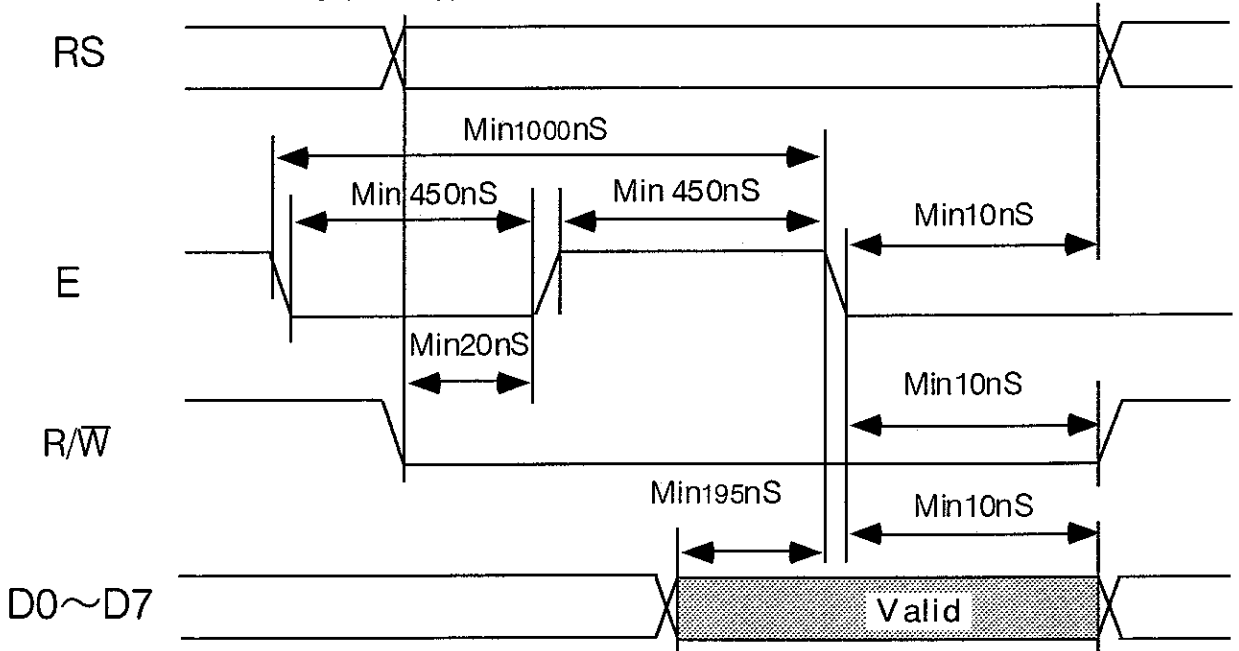

10.4 CPU bus read timing (M68 type)

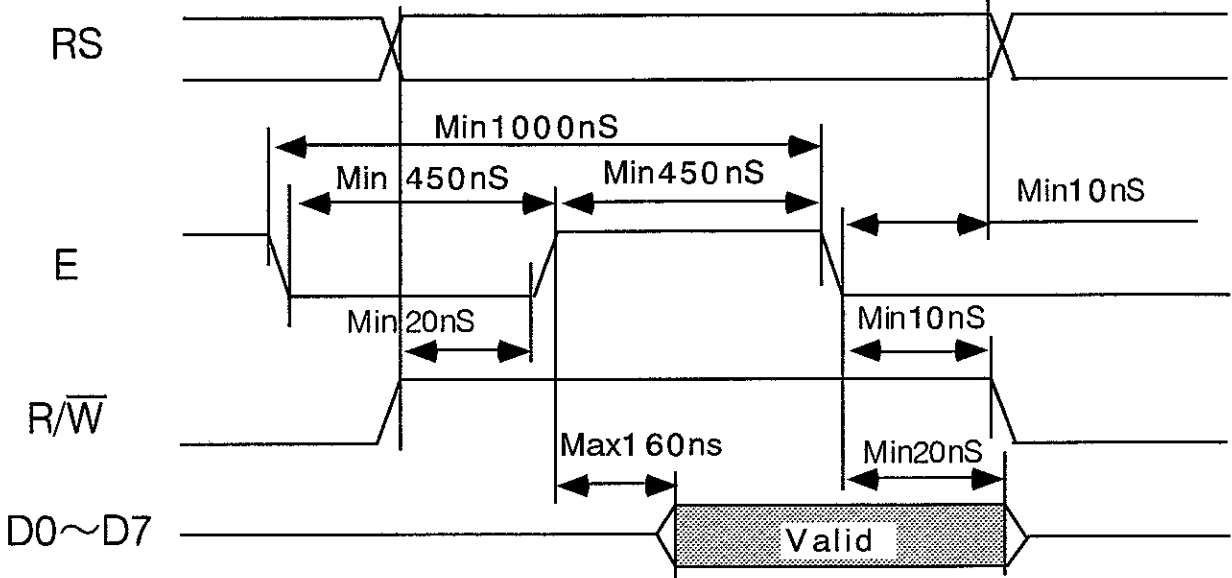

11. Connector Pin assignment

11.1 14pin Connector

Fourteen (14) through holes are prepared for power supply and data communications. A connector or pins may be able to soldered to the holes.

No.	Terminal	No.	Terminal
1	GND	8	DB1
2	VCC	9	DB2
3	※NC	10	DB3
4	RS	11	DB4
5	R/W (WR)	12	DB5
6	E (RD)	13	DB6
7	DB0	14	DB7

NC: no connection

※ The third through hole is for reset input when "R19" is short. Location and dimensions (Diameter of holes is 1.0mm.)

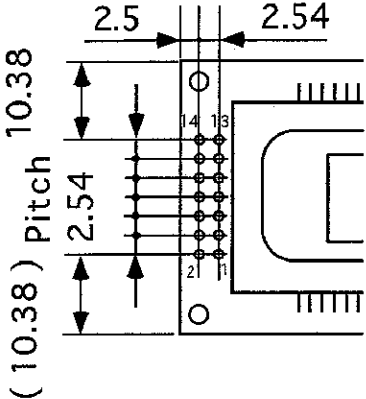

UNIT : mm

11.2 3pin Connector

A three (3) pin connector (CN2) on the board is factory use only, and may be removed in future.

12. Outline dimension

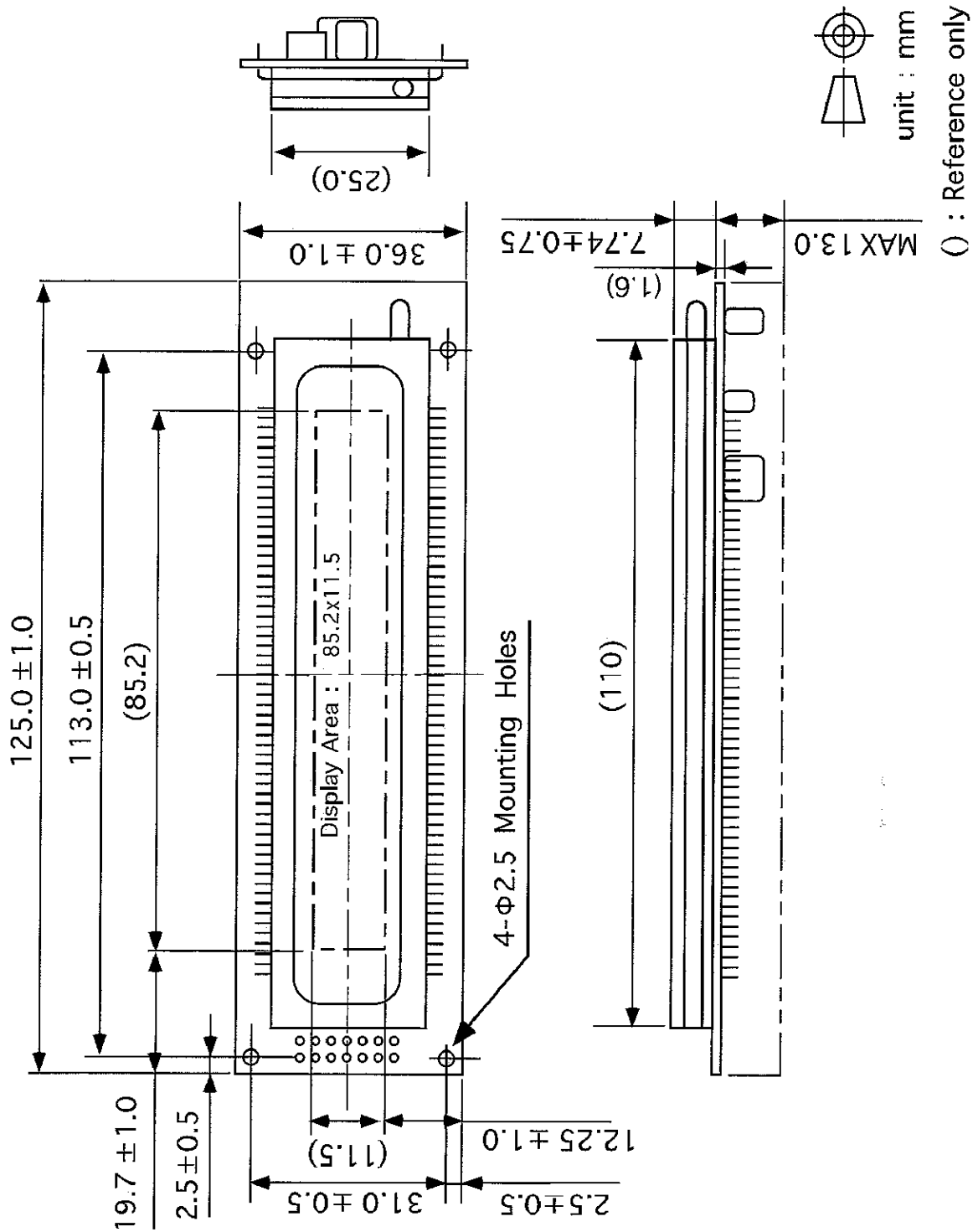

IMPORTANT PRECAUTIONS

- * All VFD Modules contain MOS LSI. Anti-Static handling procedures are always required. Tools required for assembly, such as soldering irons, must be properly grounded.
- * VF Display consists of Soda-lime glass. Heavy shock more than 100G, thermal shock greater than 10°C/minute, direct hit with hard material to the glass surface --especially to the EXHAUST PIPE -- may CRACK the glass
- * Do not PUSH the display strongly. At mounting to the system frame, slight gap between display glass face and front panel is necessary to avoid a contact failure of lead pins of display. Twist or warp mounting will make a glass CRACK around the lead pin of display.
- * Neither DATA CONNECTOR or POWER CONNECTOR should be connected or disconnected while power is applied. As is often the case with most subsystems, caution should be exercised in selectively disconnecting power within a computer based system. The modules receive high logic on strobe lines as random signals on all data ports. Removal of primary power with logic signals applied may damage input circuitry.
- * Stress more than specification listed under the Absolute Maximum Ratings may cause PERMANENT DAMAGE of the modules.
- * +5 volts power line must be regulated completely since all control logics depend on this line. Do not apply slow-start power. Provide sufficient output current power source to avoid trouble of RUSH CURRENT at power on. (At least output current of double figure of I_{cc} , listed on the specification of each module, is required.)
- * Data cable length between module and host system is recommended within 300 mm to be free from a miss-operation caused by noise.
- * Do not place the module on the conductive plate just after the power off. Due to big capacitors on the module, more than 1 min of discharging time is required to avoid the failure caused by shorting of power line.
- * 2 hours pre-running with the test mode operation may help the stability of the brightness of the VFD when power was not applied more than 2 months.
- * Steady repeating of a fixed (static) message displaying, longer than 5 hours in a day may cause the phosphor burn-out problem.