

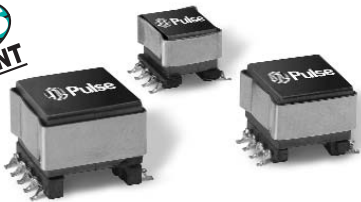



# HIGH FREQUENCY CONVENTIONAL WOUND TRANSFORMERS

## PoE Power Transformers - EP7, EP10 & EP13



-  Transformers for Power over Ethernet (PoE)
-  Power: 3W to 15W
-  Three different SMT platforms
-  Custom designs available

### Electrical Specifications @ 25°C — Operating Temperature -40°C to 125°C<sup>1</sup>

Part <sup>3</sup> Number	Application <sup>2</sup>	Turns Ratio			Primary Secondary Isolation	Primary Inductance ( $\mu\text{H} \pm 10\%$ )	Leakage Inductance ( $\mu\text{H} \text{ MAX}$ )	DCR (m $\Omega$ MAX)			
		Pri.	Sec.	Pri. Aux.				Pri. Aux.	Sec. A	Sec. B	
<b>EP7 - 8 PIN SMT - (13.3MM x 10.7MM x 9.3MM MAX) - 3W PoE FLYBACK TRANSFORMERS</b>											
PA1130NL	Vin=33-57v, Freq.=200kHz Vout=3.3v/3W, 8v/20mA	1	0.083	0.208	1500Vrms Operational	500	7.5	1750	215	15	N/A
PA1279NL	Vin=33-57v, Freq.=200kHz Vout=3.3v/3W, 12v/20mA	1	0.182	0.682		310	5	1600	2600	45	N/A
PA1131NL	Vin=33-57v, Freq.=200kHz Vout=5.0v/3W, 8v/20mA	1	0.125	0.208		500	7.5	1750	215	35	N/A
PA1280NL	Vin=33-57v, Freq.=200kHz Vout=5.0v/3W, 12v/20mA	1	0.273	0.682		310	5	1600	2650	87	N/A
PA1132NL	Vin=33-57v, Freq.=200kHz Vout=12v/3W, 8v/20mA	1	0.286	0.204		521	7.5	1750	220	100	N/A
PA1281NL	Vin=33-57v, Freq.=200kHz Vout=12v/3W, 12v/20mA	1	0.682	0.682		310	5	1600	2600	550	N/A
<b>EP10 - 8 PIN SMT - (15.2MM x 13.1MM x 11.5MM MAX) - 7W TO 10W PoE FLYBACK TRANSFORMERS</b>											
PB2115NL	Vin=36-72v, Freq.=300kHz Vout=3.3v/10W, 5.0v/100mA	1	0.100	0.150	1500Vdc Operational	25.2	2	250	20	3.25	N/A
PA1133NL	Vin=33-57v, Freq.=200kHz Vout=3.3v/7W, 8v/20mA	1	0.083	0.208	1500Vrms Operational	253	7.5	420	115	7.5	N/A
PA1253NL	Vin=33-57v, Freq.=200kHz Vout=1.8v/1A, 3.3v/1.5A, 12v/20mA	1	.0420 (1.8v) .0625 (3.3v)	0.271		253	8.5	420	335	(1.8v)	(3.3v)
PA1282NL	Vin=33-57v, Freq.=200kHz Vout=3.3v/7W, 12v/20mA	1	0.182	0.682		155	5	530	900	31	N/A
PA1277NL	Vin=9-50v, Freq.=200kHz Vout=3.3v/10W, 8v/20mA	1	0.222	0.555		20.4	1.5	80	150	7.5	N/A
PA1370NL	Vin=9-50v, Freq.=200kHz Vout=3.3v/10W, 5v/20mA	1	0.444	0.388		20.4	1.5	80	105	30	N/A
PA1134NL	Vin=33-57v, Freq.=200kHz Vout=5.0v/7W, 8v/20mA	1	0.125	0.208		253	7.5	420	115	16	N/A
PA1283NL	Vin=33-57v, Freq.=200kHz Vout=5.0v/7W, 12v/20mA	1	0.273	0.682		155	5	570	1000	40	N/A
PA1135NL	Vin=33-57v, Freq.=200kHz Vout=12v/7W, 8v/20mA	1	0.286	0.204		264	7.5	800	115	45	N/A
PA1284NL	Vin=33-57v, Freq.=200kHz Vout=12v/7W, 12v/20mA	1	0.682	0.682		155	5	540	920	370	N/A
<b>EP13 - 10 PIN SMT - (17.7MM x 14.0MM x 12.7MM MAX) - 11W TO 27W PoE FLYBACK TRANSFORMERS</b>											
PA1136NL	Vin=33-57v, Freq.=200kHz Vout=3.3v/13.5W, 8v/20mA	1	0.083	0.208	1500Vrms Operational	127	7.5	440	88	6	N/A
PA1267NL	Vin=33-57v, Freq.=200kHz Vout=3.3v/11W, 12v/20mA	1	0.167	0.639		155.5	5	330	650	11	N/A
PA1269NL	Vin=33-57v, Freq.=200kHz Vout=3.3v/13.5W, 12v/20mA	1	0.182	0.682		77.4	5	100	270	8.5	N/A
PA1137NL	Vin=33-57v, Freq.=200kHz Vout=5.0v/13.5W, 8v/20mA	1	0.125	0.208		127	7.5	460	94	12	N/A
PA1260NL	Vin=33-57v, Freq.=200kHz Vout=5.0v/13.5W, 12v/20mA	1	0.273	0.682		77.4	0.8	220	250	18	N/A
PA1138NL	Vin=33-57v, Freq.=200kHz Vout=12v/13.5W, 8v/20mA	1	0.292	0.208		127	7.5	460	94	55	N/A
PA1276NL	Vin=33-57v, Freq.=200kHz Vout=12v/13.5W, 12v/20mA	1	0.682	0.682		77.4	5	100	270	75	N/A
PA1528NL	Vin=33-57v, Freq.=200kHz Vout=15v/27W, 12v/20mA	1	0.470	0.294		28.9	1	58	55	27	N/A

# HIGH FREQUENCY CONVENTIONAL WOUND TRANSFORMERS

## PoE Power Transformers - EP7, EP10 & EP13



### Notes from Tables

1. The temperature of the component (ambient plus temperature rise) must be within the stated operating temperature range.
  2. The above transformers have been tested and approved by Pulse's power IC partners and are sited in the appropriate datasheet or evaluation board documentation at these companies.
  3. Add 'T' suffix to the part number for Tape & Reel version (ie: PA1130NLT).
- To determine which IC and IC partners are matched with the above Pulse part numbers please consult the IC Cross Reference on the Pulse website.

### Mechanicals

#### EP7

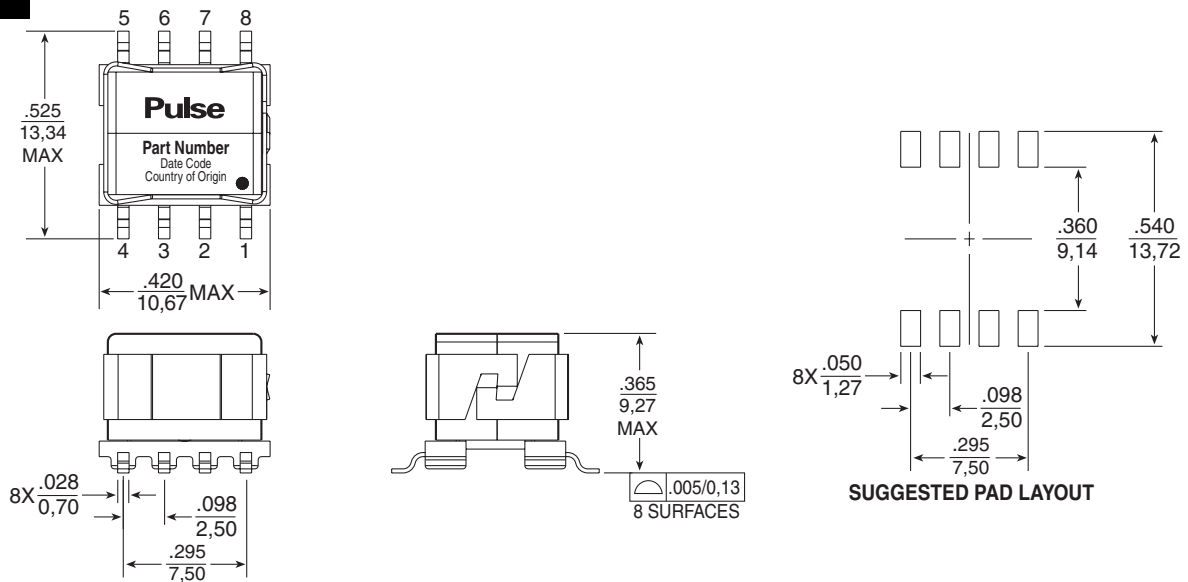

#### EP10

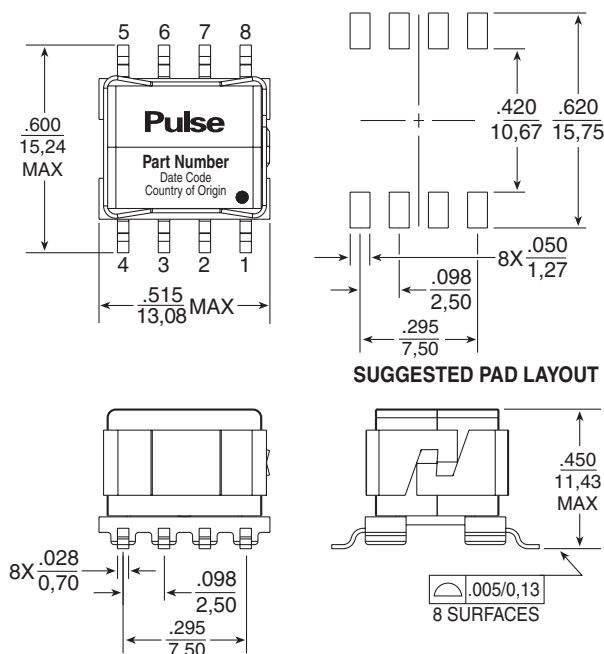

#### EP13

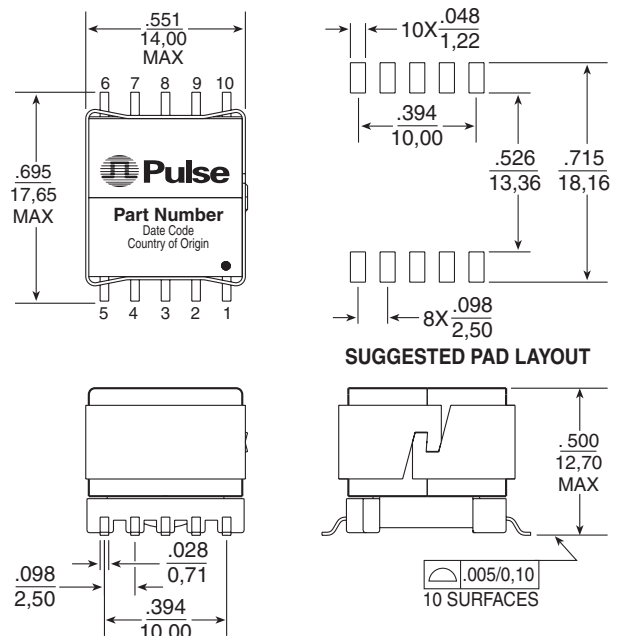

# HIGH FREQUENCY CONVENTIONAL WOUND TRANSFORMERS

## PoE Power Transformers - EP7, EP10 & EP13



### Schematics

#### EP7/10/13

**PA1253NL**

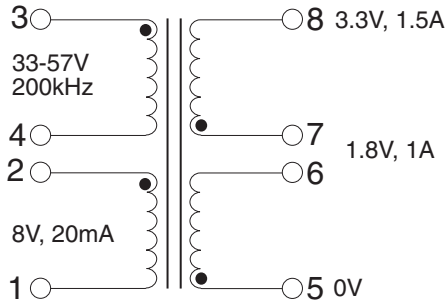

**PA1130NL / 31NL / 32NL / 33NL / 34NL / 35NL / 79NL / 80NL / 81NL / 82NL / 83NL / 84NL**

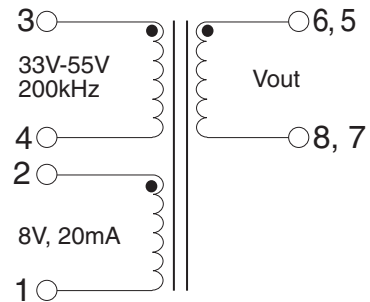

**PA1136NL, PA1137NL, PA1138NL  
PA1260NL, PA1269NL, PA1276NL, PA1528NL**

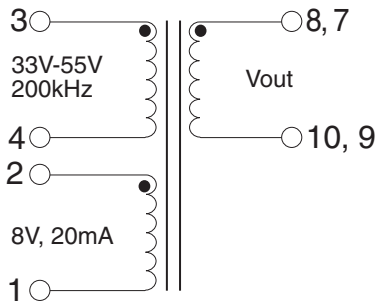

**PB2115**

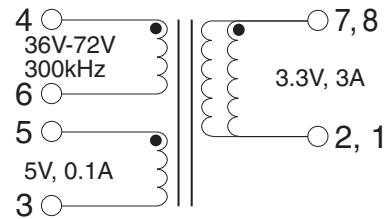

**PA1277NL, PA1370NL**

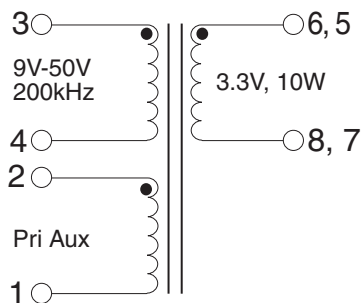

**PA1267**

