

- Cable assemblies
- D-Sub / Hoods Centronics
- Multiflex - DIN41651
- Modular
- USB IEEE1394
- Switches
- Powercords Powerlets
- DIN41612 Hardmetric
- MiniDIN
- Sockets / Strips Jumper
- Terminal Blocks
- Memory Card
- FFC / FPC

Im Zuge des zunehmenden Einsatzes von Speicherkarten, als austauschbares Medium in vielen Anwendungen der unterschiedlichsten Endprodukte, hat ASSMANN WSW components das Produktprogramm der Steckverbinder um die passenden Speicherkartensteckverbinder erweitert.

Die Anwendungen sind vielfältig, getrieben von der Computerindustrie, die schon seit vielen Jahren austauschbare Speicherkarten anbietet. Inzwischen finden wir vergleichbare Produkte in den unterschiedlichsten Applikation, angefangen von mobilen Geräten in der Telekommunikation und Industrie, Phototechnik, Navigationsgeräten im Automobilbereich und nicht zuletzt im Consumer Markt mit z.B.: I-Pots, etc.

Multimedia Card Steckverbindern (MMC) mit 7 Kontakten, im Kontaktbereich durch die feststehenden Abmaße der Speicherkarte genormt, werden von ASSMANN WSW components in den Versionen mit oder ohne Auswerfer angeboten. SD-Kartenverbinder (SD) mit 9 Kontakten, gleichfalls genormt durch die feststehenden Abmaße der Speicherkarte, sind lieferbar mit oder ohne Auswerfer, sowie alternativ als Reverse - Bauform. SIM Card Steckverbinder (SIM) mit 6 Kontakten und optionalen zusätzlichen 2 Schaltkontakten sind ebenfalls Teil der Produktpalette. Bereits seit längerer Zeit verfügbar sind die verschiedenen Varianten der 68poligen PCMCIA Steckverbinder, die aus einer Stiftleiste und einem Rahmen bestehen. Hier werden unterschiedliche Stand-Off Versionen angeboten, je nach Applikation. Neben den Standardversionen bietet ASSMANN WSW components die Kompetenz Speicherkartensteckverbinder kundenspezifisch modifiziert zu liefern.

Darüber hinaus können Druckkontaktsteckverbinder nach kundenspezifischer Anforderung konzipiert und gefertigt werden unter Erstellung von produktbezogenen Isolierkörper- und Kontaktstanzwerkzeugen. Diese Steckverbinder finden ihren Einsatz in Board to Board Verbindungen, die über eine einseitige Druckkontaktierung realisiert wird.

In line with the increasing usage of memory cards as an exchangeable medium within different applications for various devices, ASSMANN WSW components extended its connector product range by memory card connectors.

As already mentioned there are various applications, in the past driven by the computer industry, which are using memory cards as well in their end products, eg.: mobile devices in the telecom, digital camera industry, navigation devices within the car and last but not least the consumer industry, etc.

Multimedia Card connectors (MMC) with 7 contacts, an international standard due to the fixed dimensions of the card, are offered by ASSMANN WSW components with ejector or w/o ejector. SD-Card connectors (SD) with 9 contacts, as well an international standard, with and w/o ejector and alternatively available the reverse type. SIM Card connectors (SIM) with 6 contacts and optional 2 additional switching contacts are part of the product range. Already available for some years are different types of the 68 ways PCMCIA connector, consisting out of the 68 ways connector itself and a plastic frame. Different stand-off versions can be offered including ejectors or w/o ejectors. Beside these standard versions ASSMANN WSW components is able to supply customized or modified memory card products.

Furthermore single sided pressure contact connectors can be designed and manufactured according to a customer specific requirement based on customer dedicated insulator- and contact dies. Such single sided pressure contact connectors are mainly used as board to board connection on the base of direct contact to the pads on the board. Are additional information needed, please contact your sales office.

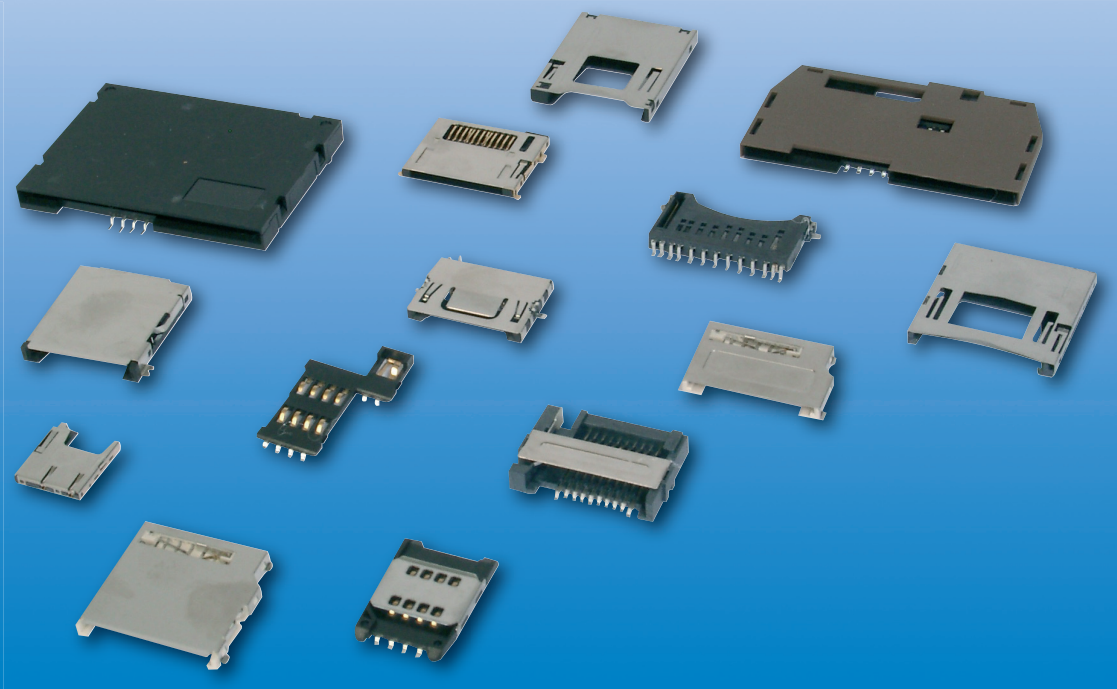

Produktbeschreibung

Seite

Multi-Media-Karten-Sockel, Reverse Ausführung	354
Multi-Media-Karten-Sockel, Standard Ausführung, anreihbar	355
SD-Karten-Sockel, Push-Pull, Stand-Off 0mm	356
SD-Karten-Sockel, Push-Pull, Reverse Ausführung, Stand-Off 0mm	357
SD-Karten-Sockel, Standard Ausführung, Stand-Off 0mm	358
SD-Karten-Sockel, Standard Ausführung, Stand-Off 0mm	359
SD-Karten-Sockel, Reverse Ausführung, Stand-Off 0mm	360
SIM-Karten-Sockel, Type 1	361
SIM-Karten-Sockel, Type 2, mit Schalter	362
SIM-Karten-Sockel, Type 3	363
SIM-Karten-Sockel, Type 4	364
SIM-Karten-Sockel, Type 5	366
SIM-Karten-Sockel, Type 6	367
PCMCIA-Karten-Sockel, Stecker	369
PCMCIA-Karten-Sockel, Buchse	370

Product description

page

Multi-media-card-socket, reverse style	354
Multi-media-card-socket, standard style, stackable	355
SD-card-socket, push-pull, stand-off 0mm	356
SD-card-socket, push-pull, reverse style, stand-off 0mm	357
SD-card-socket, standard style, stand-off 0mm	358
SD-card-socket, standard style, stand-off 0mm	359
SD-card-socket, reverse style, stand-off 0mm	360
SIM-card-socket, type 1	361
SIM-card-socket, type 2, with switch	362
SIM-card-socket, type 3	363
SIM-card-socket, type 4	364
SIM-card-socket, type 5	366
SIM-card-socket, type 6	367
PCMCIA-card-socket, male	369
PCMCIA-card-socket, female	370



Cable assemblies

D-Sub / Hoods Centronics

Multiflex - DIN41651

Modular

USB IEEE1394

Switches

Powercards Powerinlets

DIN41612 Hardmetric

MiniDIN

Sockets / Strips Jumper

Terminal Blocks

Memory Card

FFC / FPC

Cable
assemblies

D-Sub / Hoods
Centronics

Multiflex -
DIN41651

Modular

USB
IEEE1394

Switches

Powercords
Powerlets

DIN41612
Hardmetric

MiniDIN

Sockets / Strips
Jumper

Terminal Blocks

Memory Card

FFC / FPC

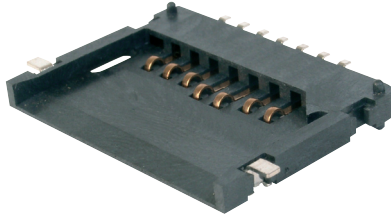

Isolierkörpermaterial
LCP, UL94V-0

Kontaktmaterial
Phosphorbronze

Kontaktoberfläche
Ni, Au / Sn

Kontaktwiderstand
100mΩ max

Isolationswiderstand
1000MΩ min

Strombelastbarkeit
1A

Betriebstemperatur
-40°C - +85°C

Verpackung
Stangenverpackung

Insulator material
LCP, UL94V-0

Contact material
Phosphor bronze

Plating
Ni, Au / Sn

Contact resistance
100mΩ max

Insulation resistance
1000MΩ min

Current rating
1A

Operating temperature
-40°C - +85°C

Packing
Tube packing

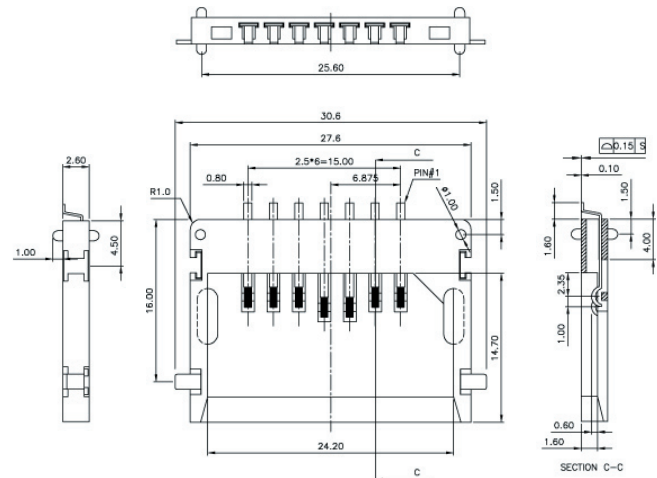
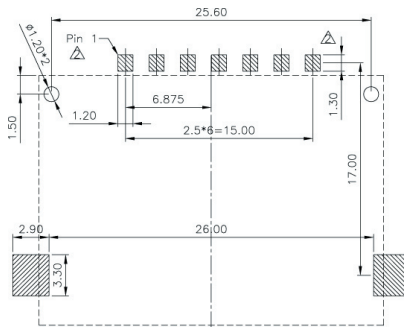

Bestellcode / Ordercode

Polzahl
07 - 07polig

No. of contacts
07 - 07-contacts

Oberfläche
S - Gold flash (Selektiv)
C - Gold 15μ" (Selektiv)

Contact plating
S - Gold flash(selective)
C - 15μ" gold (selective)

R - Reverse Ausführung

R - Reverse style

A - MMC - 07 - x - R

Bitte „x“ durch die geeignete Option ersetzen
Please replace „x“ with appropriate option

Isolierkörpermaterial

LCP, UL94V-0

Kontaktmaterial

Phosphorbronze

Kontaktfläche

Ni, Au / Sn

Kontaktwiderstand

100mΩ max

Isolationswiderstand

1000MΩ min

Strombelastbarkeit

1A

Betriebstemperatur

-40°C - +85°C

Verpackung

Stangenverpackung

Insulator material

LCP, UL94V-0

Contact material

Phosphor bronze

Plating

Ni, Au / Sn

Contact resistance

100mΩ max

Insulation resistance

1000MΩ min

Current rating

1A

Operating temperature

-40°C - +85°C

Packing

Tube packing

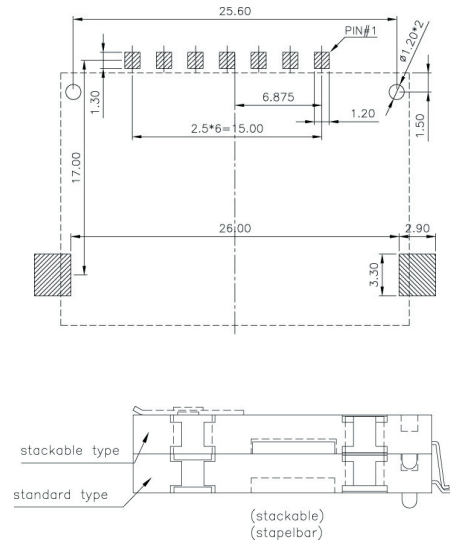
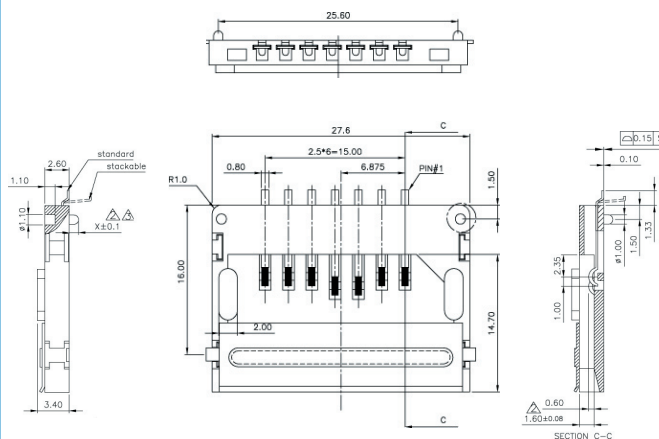
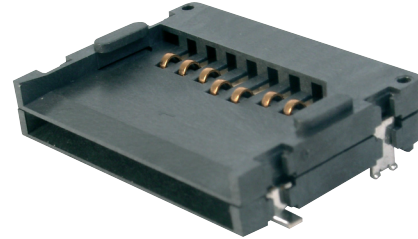

Bestellcode / Ordercode

Polzahl

07 - 07polig

Positionierstift (Wert für X)

1 - 1.0mm (Standard)
 2 - 0.6mm

Ausführung

1 - einlagig
 2 - zweilagig
 3 - dreilagig

Kontaktfläche

S - Gold flash (Selektiv)
 C - Gold 15µ" (Selektiv)

No. of contacts

07 - 07-contacts

Positioning Pin (Dim for X)

1 - 1.0mm (Standard)
 2 - 0.6mm

Assemble Style

1 - one layer
 2 - two layer
 3 - three layer

Contact plating

S - Gold flash(selective)
 C - 15µ" gold (selective)

A - MMC - 07 - x - A - x - x

Bitte „x“ durch die geeignete Option ersetzen
 Please replace „x“ with appropriate option

- Cable assemblies
- D-Sub / Hoods Centronics
- Multiflex - DIN41651
- Modular
- USB IEEE1394
- Switches
- Powercards Powernets
- DIN41612 Hardmetric
- MiniDIN
- Sockets / Strips Jumper
- Terminal Blocks
- Memory Card
- FFC / FPC

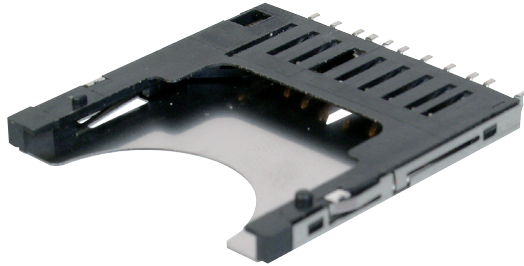

Isolierkörpermaterial
LCP, UL94V-0

Kontaktmaterial
Phosphorbronze

Kontaktfläche
Ni, Au / Sn

Kontaktwiderstand
40mΩ max

Isolationswiderstand
1000MΩ min

Strombelastbarkeit
0.5A

Betriebstemperatur
-20°C - +85°C

Prüfspannung
250V AC

Verpackung
Blisterverpackung

Insulator material
LCP, UL94V-0

Contact material
Phosphor bronze

Plating
Ni, Au / Sn

Contact resistance
40mΩ max

Insulation resistance
1000MΩ min

Current rating
0.5A

Operating temperature
-20°C - +85°C

Test voltage
250V AC

Packing
Tray packing

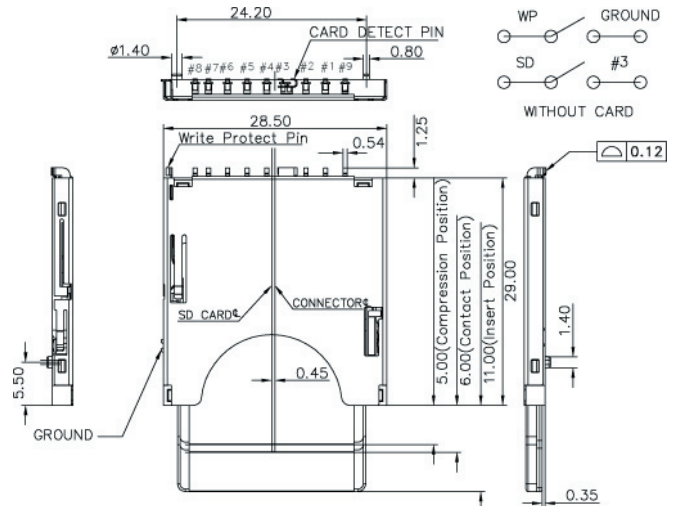
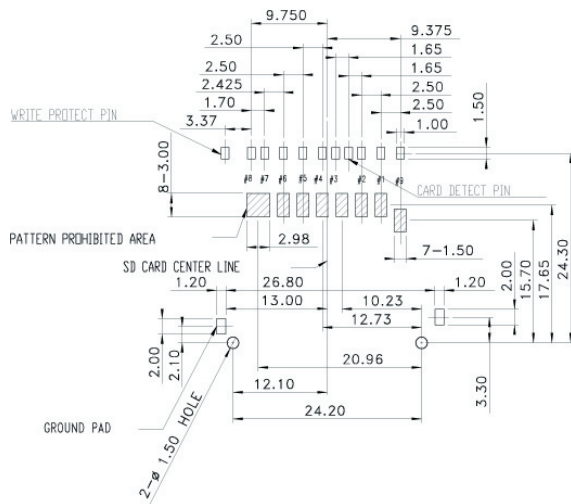

Bestellcode / Ordercode

Polzahl
09 - 09polig

No. of contacts
09 - 09-contacts

Kontaktfläche
S - Gold flash (Selektiv)
C - Gold 15μ" (Selektiv)

Contact plating
S - Gold flash(selective)
C - 15μ" gold (selective)

A - SD - 09 - x - A - 1 - 3

Bitte „x“ durch die geeignete Option ersetzen
Please replace „x“ with appropriate option

Isolierkörpermaterial

LCP, UL94V-0

Kontaktmaterial

Phosphorbronze

Kontaktfläche

Ni, Au / Sn

Kontaktwiderstand

40mΩ max

Isolationswiderstand

1000MΩ min

Strombelastbarkeit

0.5A

Betriebstemperatur

-20°C - +85°C

Prüfspannung

250V AC

Verpackung

Blisterverpackung

Insulator material

LCP, UL94V-0

Contact material

Phosphor bronze

Plating

Ni, Au / Sn

Contact resistance

40mΩ max

Insulation resistance

1000MΩ min

Current rating

0.5A

Operating temperature

-20°C - +85°C

Test voltage

250V AC

Packing

Tray packing

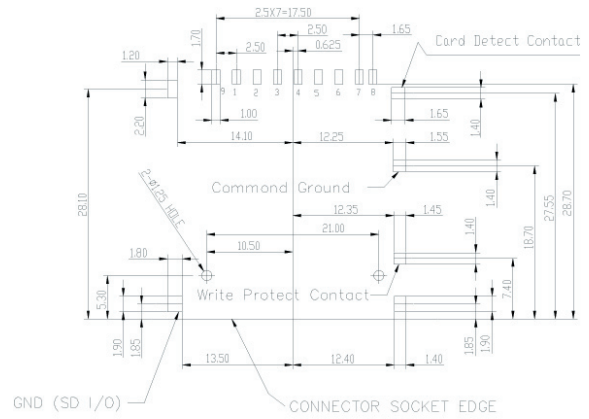
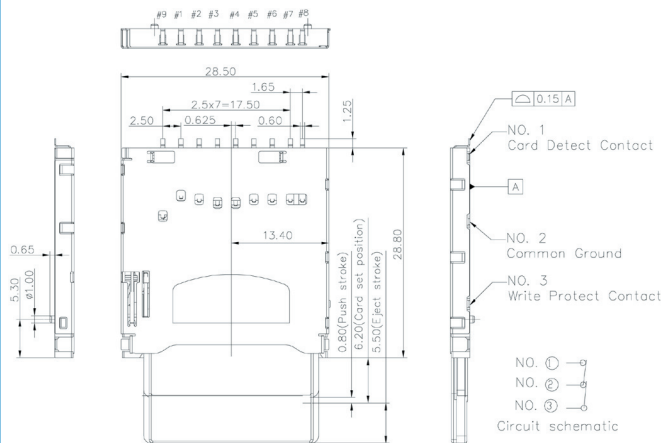
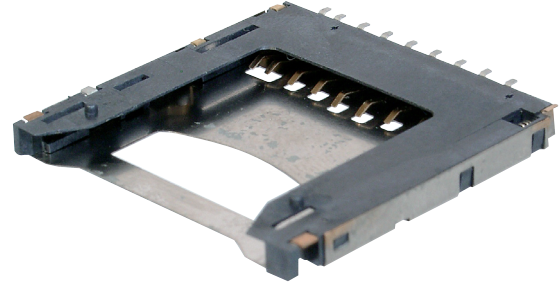

Bestellcode / Ordercode

Polzahl

09 - 09polig

No. of contacts

09 - 09-contacts

Oberfläche

S - Gold flash (Selektiv)

C - Gold 15µ" (Selektiv)

Contact plating

S - Gold flash(selective)

C - 15µ" gold (selective)

E - Reverse Ausführung

E - Reverse style

A - SD - 09 - x - E - 1 - 3

Bitte „x“ durch die geeignete Option ersetzen
 Please replace „x“ with appropriate option

Cable assemblies

D-Sub / Hoods Centronics

Multiflex - DIN41651

Modular

USB IEEE1394

Switches

Powercards Powernets

DIN41612 Hardmetric

MiniDIN

Sockets / Strips Jumper

Terminal Blocks

Memory Card

FFC / FPC

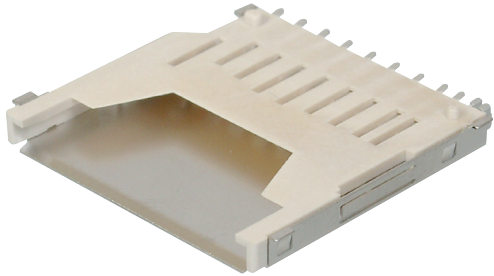

Isolierkörpermaterial

LCP, UL94V-0

Kontaktmaterial

Phosphorbronze

Kontaktoberfläche

Ni, Au / Sn

Kontaktwiderstand

100mΩ max

Isolationswiderstand

1000MΩ min

Strombelastbarkeit

1A

Betriebstemperatur

-20°C - +85°C

Prüfspannung

250V AC

Verpackung

Blisterverpackung

Insulator material

LCP, UL94V-0

Contact material

Phosphor bronze

Plating

Ni, Au / Sn

Contact resistance

100mΩ max

Insulation resistance

1000MΩ min

Current rating

1A

Operating temperature

-20°C - +85°C

Test voltage

250V AC

Packing

Tray packing

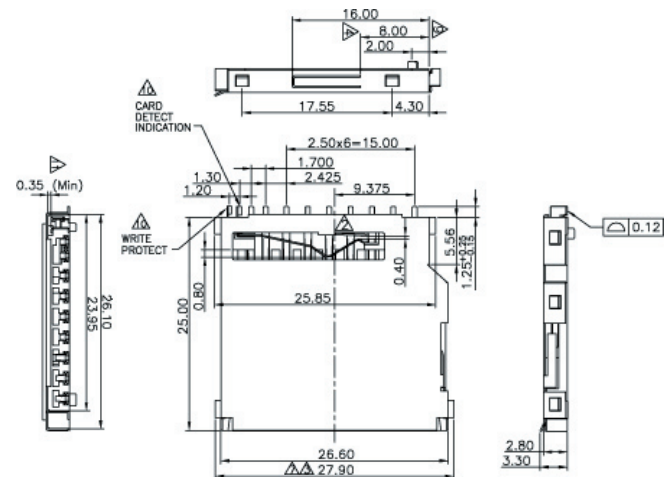
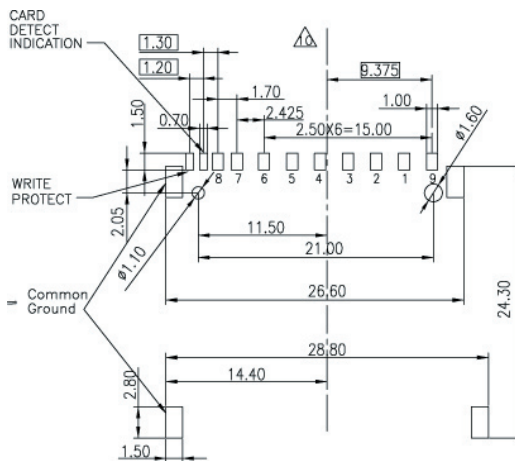

Bestellcode / Ordercode

Polzahl

09 - 09polig

No. of contacts

09 - 09-contacts

Kontaktoberfläche

S - Gold flash (Selektiv)

C - Gold 15µ" (Selektiv)

Contact plating

S - Gold flash(selective)

C - 15µ" gold (selective)

A - SD - 09 - x - 0 - 7 - 3

Bitte „x“ durch die geeignete Option ersetzen
Please replace „x“ with appropriate option

Isolierkörpermaterial

LCP, UL94V-0

Kontaktmaterial

Phosphorbronze

Kontaktoberfläche

Ni, Au / Sn

Kontaktwiderstand

100mΩ max

Isolationswiderstand

1000MΩ min

Strombelastbarkeit

1A

Betriebstemperatur

-40°C - +85°C

Prüfspannung

250V AC

Verpackung

Blisterverpackung

Insulator material

LCP, UL94V-0

Contact material

Phosphor bronze

Plating

Ni, Au / Sn

Contact resistance

100mΩ max

Insulation resistance

1000MΩ min

Current rating

1A

Operating temperature

-40°C - +85°C

Test voltage

250V AC

Packing

Tray packing

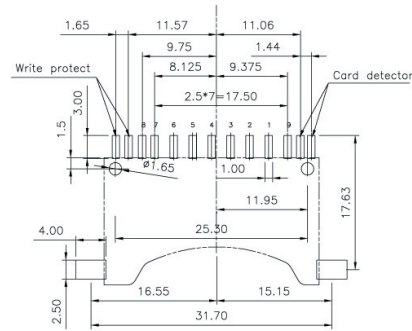
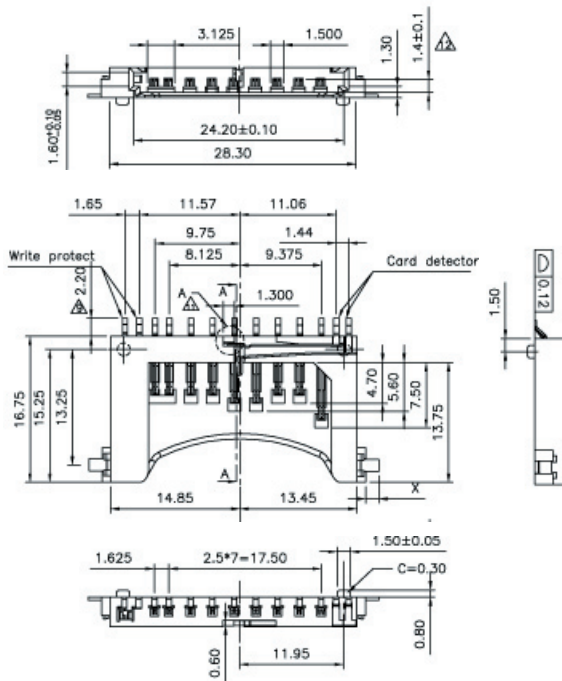
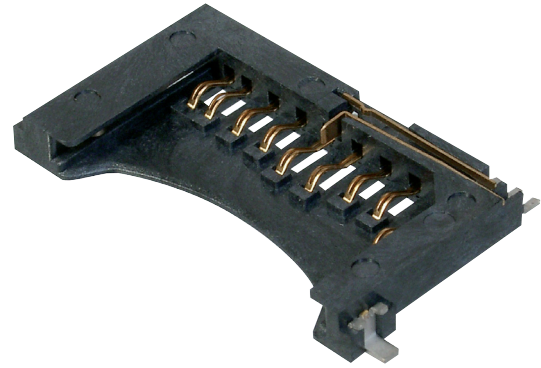

Bestellcode / Ordercode

Polzahl

09 - 09polig

No. of contacts

09 - 09-contacts

Anschluss (Dim. für X)

0 - 1.5mm
 1 - 1.0mm

Tap option (Dim. for X)

0 - 1.5mm
 1 - 1.0mm

Kontaktoberfläche

S - Gold flash (Selektiv)
 C - Gold 15µ" (Selektiv)

Contact plating

S - Au flash(selective)
 C - 15µ" Au (selective)

A - SD - 09 - x - 0 - x - 3

Bitte „x“ durch die geeignete Option ersetzen
 Please replace „x“ with appropriate option

Cable assemblies

D-Sub / Hoods Centronics

Multiflex - DIN41651

Modular

USB IEEE1394

Switches

Powercards Powerinlets

DIN41612 Hardmetric

MiniDIN

Sockets / Strips Jumper

Terminal Blocks

Memory Card

FFC / FPC

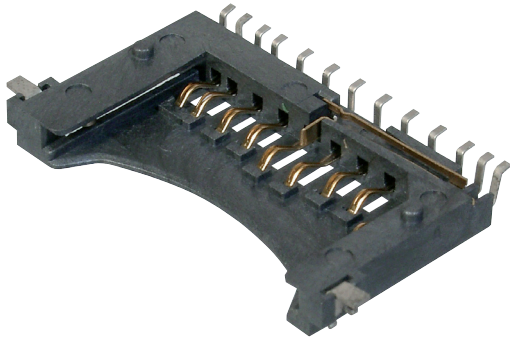

Isolierkörpermaterial

LCP, UL94V-0

Kontaktmaterial

Phosphorbronze

Kontaktoberfläche

Ni, Au / Sn

Kontaktwiderstand

100mΩ max

Isolationswiderstand

1000MΩ min

Strombelastbarkeit

1A

Betriebstemperatur

-20°C - +85°C

Prüfspannung

250V AC

Verpackung

Blisterverpackung

Insulator material

LCP, UL94V-0

Contact material

Phosphor bronze

Plating

Ni, Au / Sn

Contact resistance

100mΩ max

Insulation resistance

1000MΩ min

Current rating

1A

Operating temperature

-20°C - +85°C

Test voltage

250V AC

Packing

Tray packing

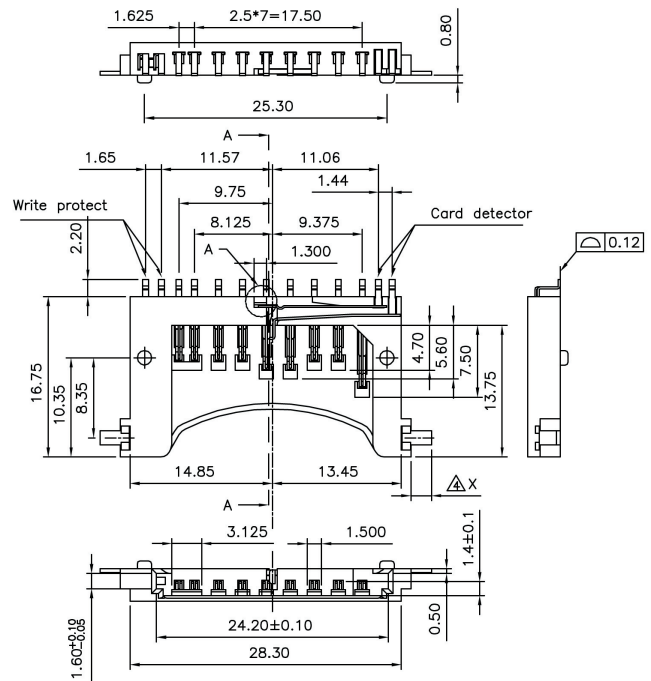
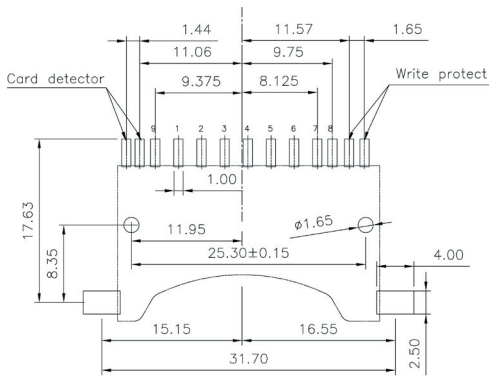

Bestellcode / Ordercode

Polzahl

09 - 09polig

No. of contacts

09 - 09-contacts

Anschluss (Dim. für X)

0 - 1.5mm

1 - 0.8mm

Tap option (Dim. For X)

0 - 1.5mm

1 - 0.8mm

R - Reverse Ausführung

R - Reverse style

Oberfläche

S - Gold flash (Selektiv)

C - Gold 15μ" (Selektiv)

Contact plating

S - Gold flash(selective)

C - 15μ" gold (selective)

A - SD - 09 - x - R - x - 3

Bitte „x“ durch die geeignete Option ersetzen
Please replace „x“ with appropriate option

Isolierkörpermaterial

LCP, UL94V-0

Kontaktmaterial

Phosphorbromzwe

Kontaktfläche

A: Ni, Au / Sn

B: Ni, Sn

Kontaktwiderstand

100mΩ max

Isolationswiderstand

1000MΩ min

Strombelastbarkeit

0.5A

Betriebstemperatur

-40°C - +85°C

Prüfspannung

500V AC

Verpackung

Blisterverpackung

Insulator material

LCP, UL94V-0

Contact material

Phosphor bronze

Plating

A: Ni, Au / Sn

B: Ni, Sn

Contact resistance

100mΩ max

Insulation resistance

1000MΩ min

Current rating

0.5A

Operating temperature

-40°C - +85°C

Test voltage

500V AC

Packing

Tray packing

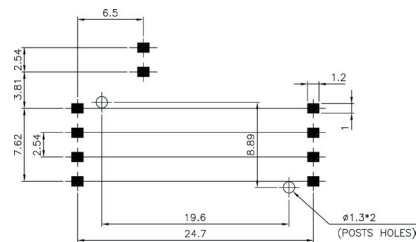
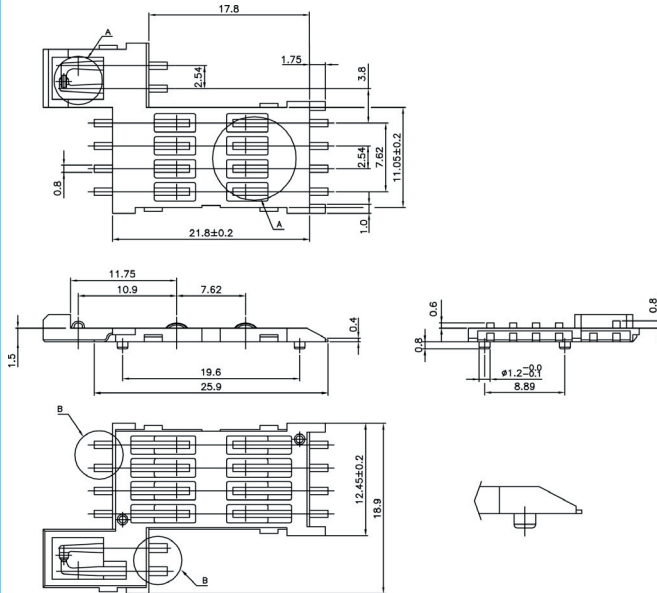
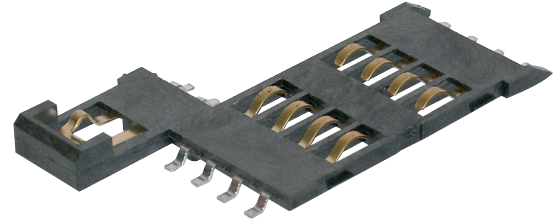

Bestellcode / Ordercode

Polzahl

08 - 08polig

No. of contacts

08 - 08-contacts

Kontaktfläche

S - Gold flash (Selektiv)

C - Gold 15μ" (Selektiv)

Contact plating

S - Gold flash(selective)

C - 15μ" gold (selective)

A - SIM - 08 - 01 - x - 003

Bitte „x“ durch die geeignete Option ersetzen
 Please replace „x“ with appropriate option

Cable assemblies

D-Sub / Hoods Centronics

Multiflex - DIN41651

Modular

USB IEEE1394

Switches

Powercards Powernets

DIN41612 Hardmetric

MiniDIN

Sockets / Strips Jumper

Terminal Blocks

Memory Card

FFC / FPC

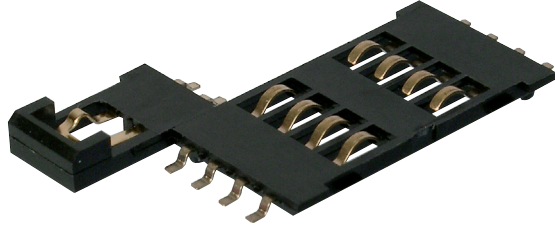

Isolierkörpermaterial
LCP, UL94V-0

Kontaktmaterial
Phosphorbromzinn

Kontaktfläche
A: Ni, Au / Sn
B: Ni, Sn

Kontaktwiderstand
100mΩ max

Isolationswiderstand
1000MΩ min

Strombelastbarkeit
0.5A

Betriebstemperatur
-40°C - +105°C

Prüfspannung
500V AC

Verpackung
Blisterverpackung

Insulator material
LCP, UL94V-0

Contact material
Phosphor bronze

Plating
A: Ni, Au / Sn
B: Ni, Sn

Contact resistance
100mΩ max

Insulation resistance
1000MΩ min

Current rating
0.5A

Operating temperature
-40°C - +105°C

Test voltage
500V AC

Packing
Tray packing

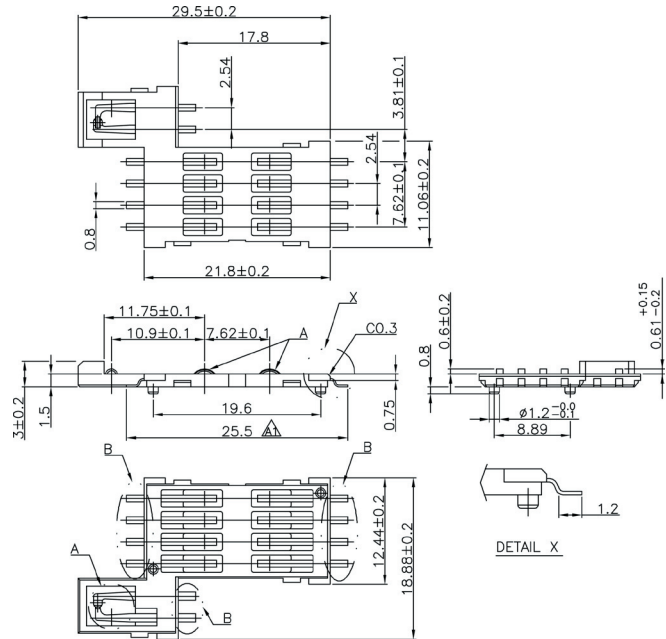
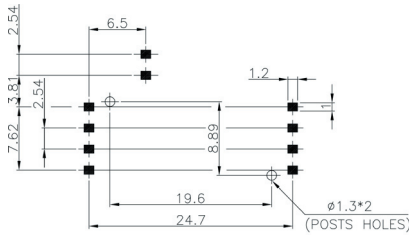

Bestellcode / Ordercode

Polzahl
08 - 08polig

No. of contacts
08 - 08-contacts

Kontaktfläche
S - Gold flash (Selektiv)
C - Gold 15µ" (Selektiv)

Contact plating
S - Gold flash(selective)
C - 15µ" gold (selective)

A - SIM - 08 - 02 - x - 003

Bitte „x“ durch die geeignete Option ersetzen
Please replace „x“ with appropriate option

Cable
assemblies

D-Sub / Hoods
Centronics

Multiflex -
DIN41651

Modular

USB
IEEE1394

Switches

Powercords
Powerlets

DIN41612
Hardmetric

MiniDIN

Sockets / Strips
Jumper

Terminal Blocks

Memory Card

FFC / FPCC

SIM-Karten-Sockel, Type 3
SIM-card-socket, type 3

Isolierkörpermaterial

LCP, UL94V-0

Kontaktmaterial

Phosphorbronze

Kontaktfläche

Ni, Au / Sn

Kontaktwiderstand

100mΩ max

Isolationswiderstand

1000MΩ min

Strombelastbarkeit

0.5A

Betriebstemperatur

-40°C - +85°C

Prüfspannung

500V AC

Verpackung

Blisterverpackung

Insulator material

LCP, UL94V-0

Contact material

Phosphor bronze

Plating

Ni, Au / Sn

Contact resistance

100mΩ max

Insulation resistance

1000MΩ min

Current rating

0.5A

Operating temperature

-40°C - +85°C

Test voltage

500V AC

Packing

Tray packing

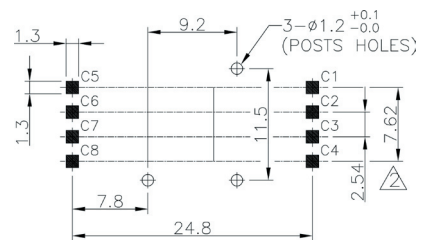
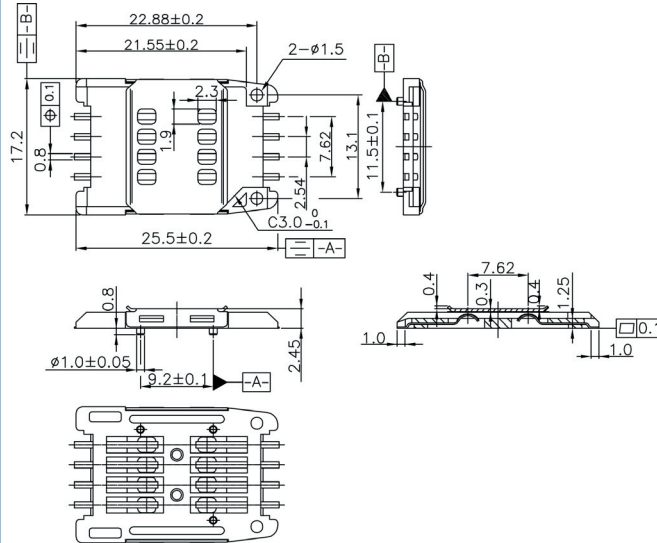

Bestellcode / Ordercode

Polzahl

08 - 08polig

No. of contacts

08 - 08-contacts

Kontaktfläche

S - Gold flash (Selektiv)
 C - Gold 15µ" (Selektiv)

Contact plating

S - Gold flash(selective)
 C - 15µ" gold (selective)

A - SIM - 08 - 03 - x - 003

Bitte „x“ durch die geeignete Option ersetzen
 Please replace „x“ with appropriate option

Cable assemblies

D-Sub / Hoods Centronics

Multiflex - DIN41651

Modular

USB IEEE1394

Switches

Powercards Powerinlets

DIN41612 Hardmetric

MiniDIN

Sockets / Strips Jumper

Terminal Blocks

Memory Card

FFC / FPC

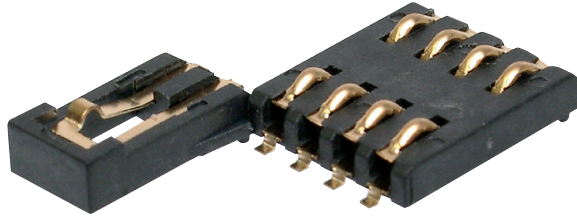

Isolierkörpermaterial
LCP, UL94V-0

Kontaktmaterial
Phosphorbronze

Kontaktoberfläche
Ni, Au

Kontaktwiderstand
50mΩ max

Isolationswiderstand
1000MΩ min

Strombelastbarkeit
1A

Betriebstemperatur
-25°C - +60°C

Prüfspannung
1000V AC

Verpackung
Rollenverpackung

Insulator material
LCP, UL94V-0

Contact material
Phosphor bronze

Plating
Ni, Au

Contact resistance
50mΩ max

Insulation resistance
1000MΩ min

Current rating
1A

Operating temperature
-25°C - +60°C

Test voltage
1000V AC

Packing
Reel packing

Platings		
A	B	C
30μ" GOLD	4μ" GOLD	GOLD FLASH

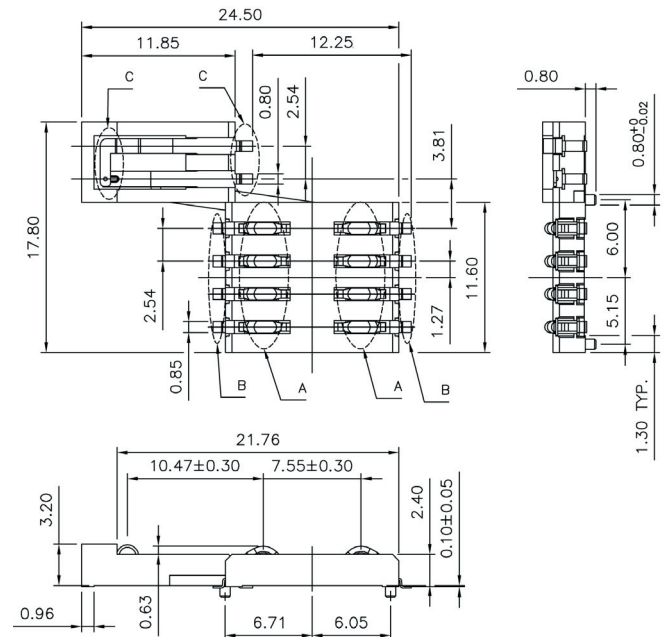
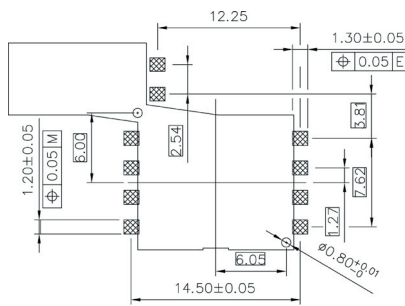

Bestellcode / Ordercode

Polzahl
08 - 08polig

No. of contacts
08 - 08-contacts

A - SIM - 08 - 04 - Z - 003

Cable
assemblies

D-Sub / Hoods
Centronics

Multiflex -
DIN41651

Modular

USB
IEEE1394

Switches

Powercords
Powerlets

DIN41612
Hardmetric

MiniDIN

Sockets / Strips
Jumper

Terminal Blocks

Memory Card

FFC / FPC

Verpackung entspricht
EIA-481-C.

Packing correspond with
EIA-481-C.

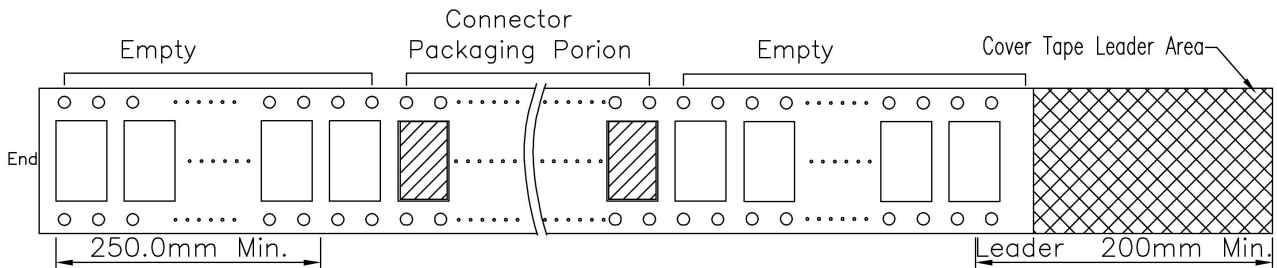
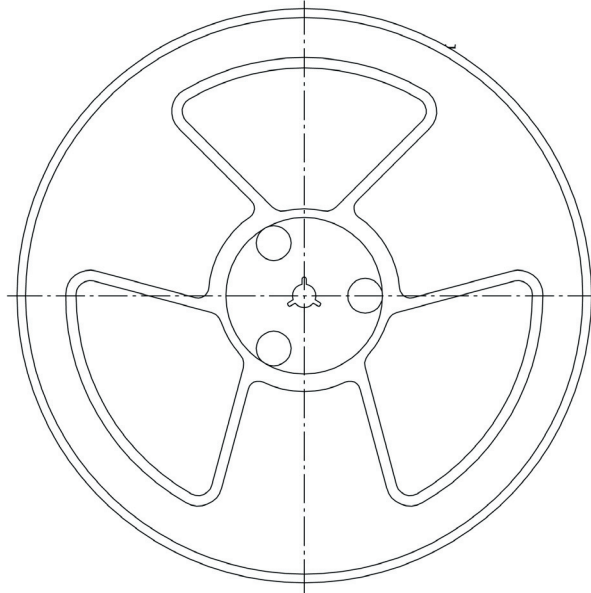
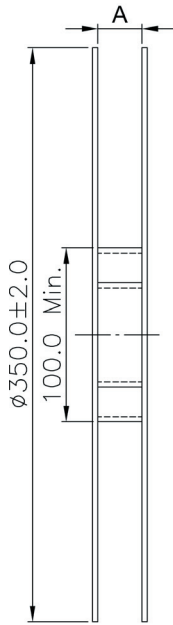

direction of feed

No. of contacts	A	Qty per Reel
8	44	500

Cable
assemblies

D-Sub / Hoods
Centronics

Multiflex -
DIN41651

Modular

USB
IEEE1394

Switches

Powercards
Powerinlets

DIN41612
Hardmetric

MiniDIN

Sockets / Strips
Jumper

Terminal Blocks

Memory Card

FFC / FPC



Isolierkörpermaterial
LCP, UL94V-0

Kontaktmaterial
Phosphorbromze

Kontaktoberfläche
Ni, Au / Sn

Kontaktwiderstand
100mΩ max

Isolationswiderstand
1000MΩ min

Strombelastbarkeit
1A

Betriebstemperatur
-40°C - +90°C

Prüfspannung
500V AC

Verpackung
Blisterverpackung

Insulator material
LCP, UL94V-0

Contact material
Phosphor bronze

Plating
Ni, Au / Sn

Contact resistance
100mΩ max

Insulation resistance
1000MΩ min

Current rating
1A

Operating temperature
-40°C - +90°C

Test voltage
500V AC

Packing
Tray packing

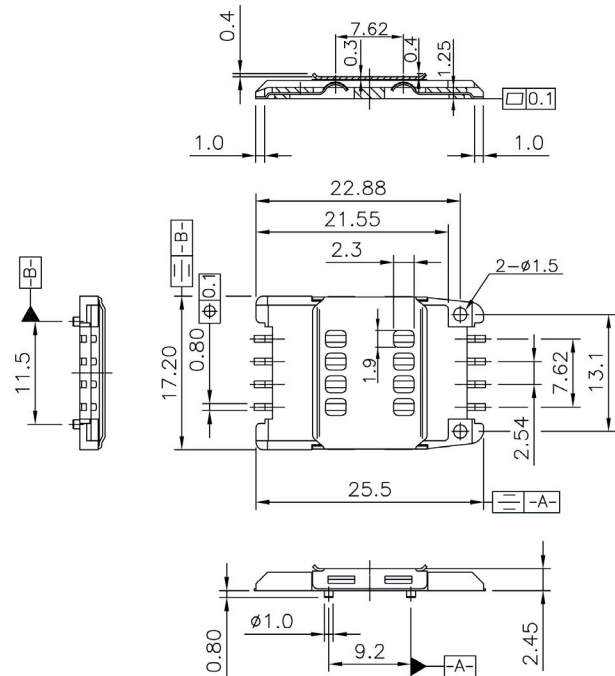
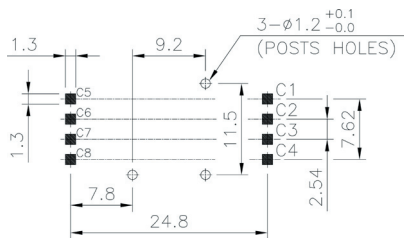

Bestellcode / Ordercode

Polzahl
08 - 08polig

No. of contacts
08 - 08-contacts

Kontaktoberfläche
S - Gold flash (Selektiv)
C - Gold 15 μ " (Selektiv)

Contact plating
S - Gold flash(selective)
C - 15 μ " gold (selective)

A - SIM - 08 - 05 - x - 003

Bitte „x“ durch die geeignete Option ersetzen
Please replace „x“ with appropriate option

- Cable assemblies
- D-Sub / Hoods
- Centronics
- Multiflex - DIN41651
- Modular
- USB IEEE1394
- Switches
- Powercords Powerlets
- DIN41612 Hardmetric
- MiniDIN
- Sockets / Strips Jumper
- Terminal Blocks
- Memory Card
- FFC / FPIC

SIM-Karten-Sockel, Type 6
SIM-card-socket, type 6

Isolierkörpermaterial

LCP, UL94V-0

Kontaktmaterial

Phosphorbromzwe

Kontaktoberfläche

Ni, Au / Sn

Kontaktwiderstand

30mΩ max

Isolationswiderstand

500MΩ min

Strombelastbarkeit

0.5A

Betriebstemperatur

-55°C - +85°C

Prüfspannung

250V AC

Verpackung

Rollenverpackung

Insulator material

LCP, UL94V-0

Contact material

Phosphor bronze

Plating

Ni, Au / Sn

Contact resistance

30mΩ max

Insulation resistance

500MΩ min

Current rating

0.5A

Operating temperature

-55°C - +85°C

Test voltage

250V AC

Packing

Reel packing

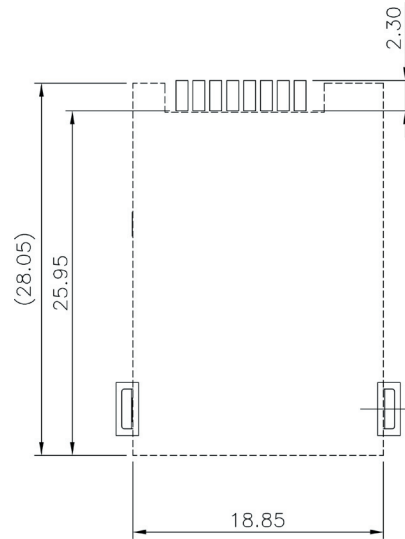
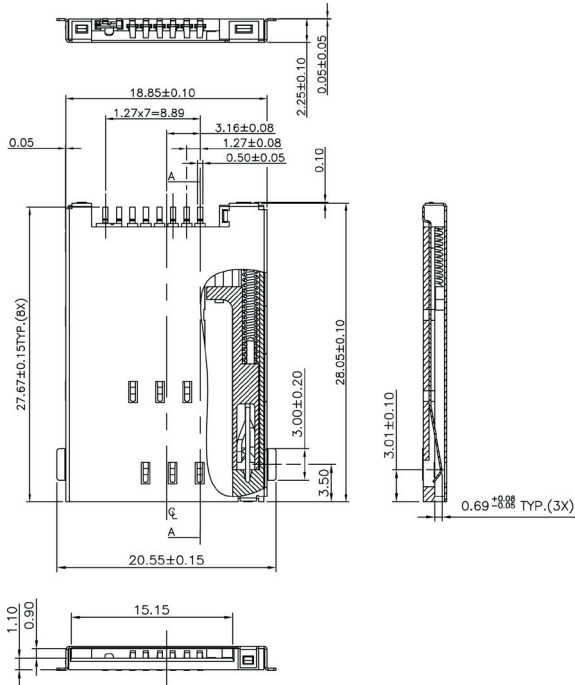
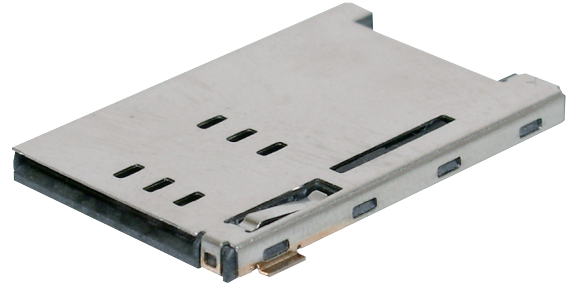

Bestellcode / Ordercode

Polzahl

08 - 08polig

No. of contacts

08 - 08-contacts

Kontaktoberfläche

S - Gold flash (Selektiv)
 C - Gold 15μ" (Selektiv)

Contact plating

S - Gold flash(selective)
 C - 15μ" gold (selective)

A - SIM - 08 - 06 - x - 003

Bitte „x“ durch die geeignete Option ersetzen
 Please replace „x“ with appropriate option

Cable assemblies

D-Sub / Hoods Centronics

Multiflex - DIN41651

Modular

USB IEEE1394

Switches

Powercards Powerinlets

DIN41612 Hardmetric

MiniDIN

Sockets / Strips Jumper

Terminal Blocks

Memory Card

FFC / FPC

Verpackung entspricht
EIA-481-C.

Packing correspond with
EIA-481-C.

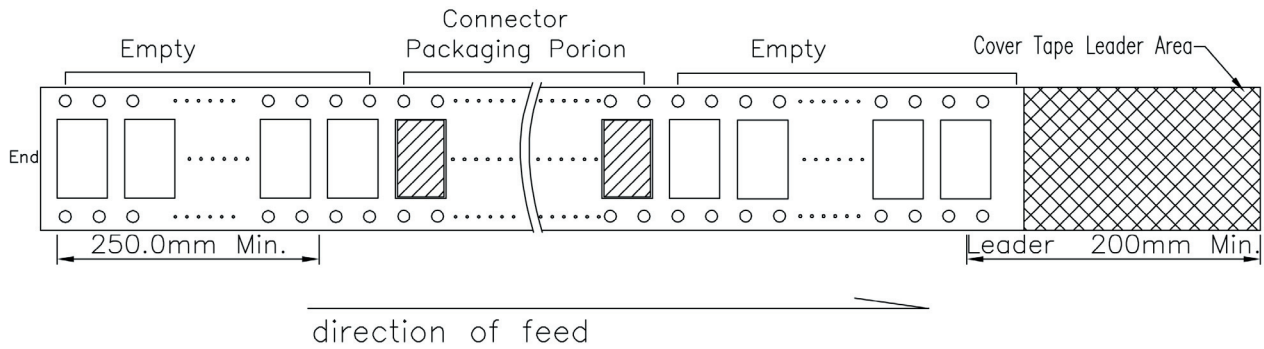
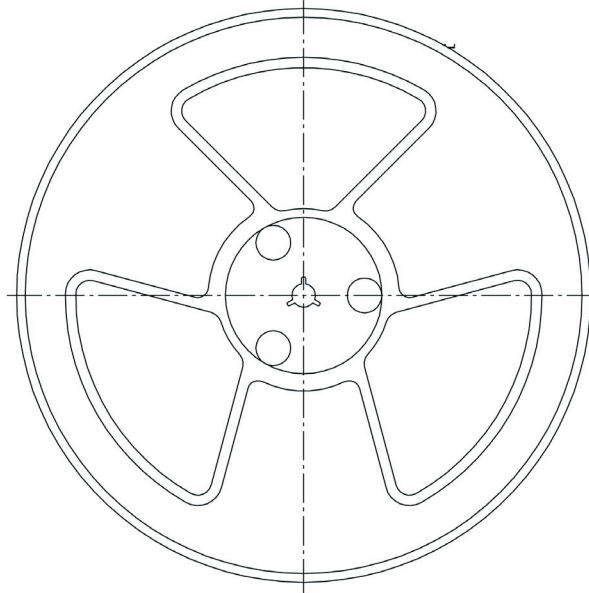
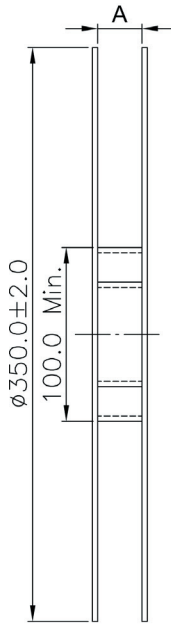

No. of contacts	A	Qty per Reel
8	44	700

Cable
assemblies

D-Sub / Hoods
Centronics

Multiflex -
DIN41651

Modular

USB
IEEE1394

Switches

Powercords
Powerlets

DIN41612
Hardmetric

MiniDIN

Sockets / Strips
Jumper

Terminal Blocks

Memory Card

FFC / FPC

Isolierkörpermaterial
 PA9T, UL94V-0

Kontaktmaterial
 Phosphorbromzse

Kontaktoberfläche
 Ni, Au / Sn

Kontaktwiderstand
 40mΩ max

Isolationswiderstand
 1000MΩ min

Strombelastbarkeit
 1A

Betriebstemperatur
 -40°C - +85°C

Prüfspannung
 1000V AC

Verpackung
 Blisterverpackung

Insulator material
 PA9T, UL94V-0

Contact material
 Phosphor bronze

Plating
 Ni, Au / Sn

Contact resistance
 40mΩ max

Insulation resistance
 1000MΩ min

Current rating
 1A

Operating temperature
 -40°C - +85°C

Test voltage
 1000V AC

Packing
 Tray packing

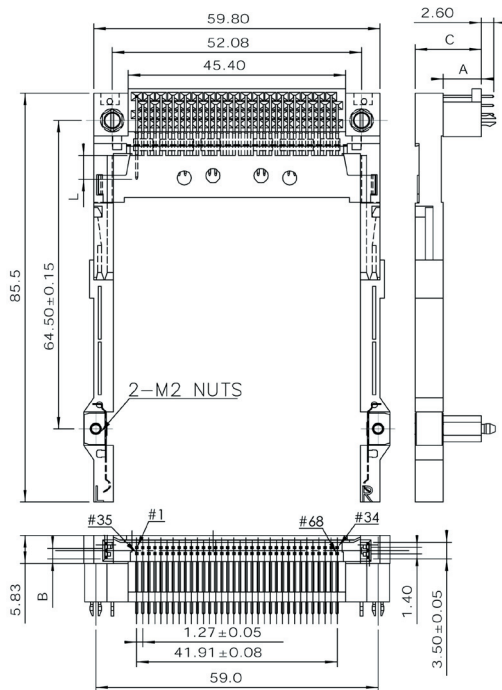
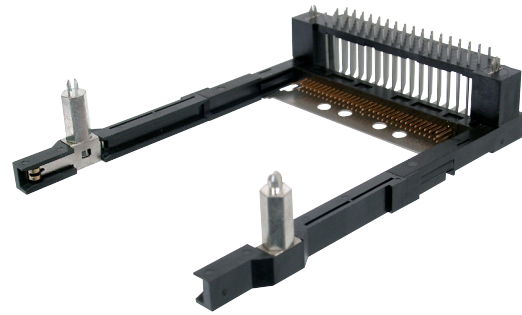

Description	Pin Number	L±0.10
Power	1 / 17 / 34 / 35 / 51 / 68	5.00
General	All other pins	4.25
Detect	36 / 67	3.50

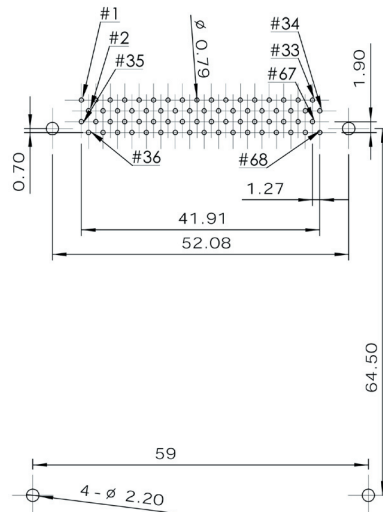

Bestellcode / Ordercode

Zubehör

- 0 - ohne Gewindemutter M2
- 1 - mit Gewindemutter M2

Betriebsspannung & Dim B

- 1 - 5.0V - 1.1mm
- 2 - 3.3V - 2.2mm

Abstand Dim A & Dim C

- 1 - 4.0mm / 9.83mm
- 5 - 7.0mm / 12.83mm
- 8 - 10.0mm / 15.83mm

Kontaktoberfläche

- S - Gold flash (Selektiv)
- C - Gold 15µ" (Selektiv)

Parts option

- 0 - without Nut M2
- 1 - with Nut M2

Voltage & Dim B

- 1 - 5.0V - 1.1mm
- 2 - 3.3V - 2.2mm

Stand-off Dim A & Dim C

- 1 - 4.0mm / 9.83mm
- 5 - 7.0mm / 12.83mm
- 8 - 10.0mm / 15.83mm

Contact plating

- S - Gold flash(selective)
- C - 15µ" gold (selective)

A - PCMCIA - 68 - x - x - x - x

Bitte „x“ durch die geeignete Option ersetzen
 Please replace „x“ with appropriate option

Cable assemblies

D-Sub / Hoods Centronics

Multiflex - DIN41651

Modular

USB IEEE1394

Switches

Powercards Powerinlets

DIN41612 Hardmetric

MiniDIN

Sockets / Strips Jumper

Terminal Blocks

Memory Card

FFC / FPC

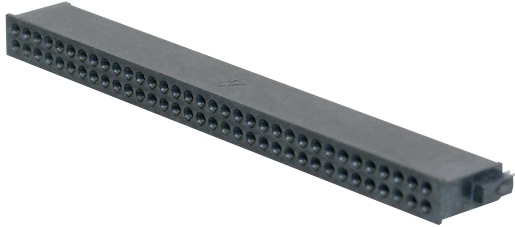

Isolierkörpermaterial

PA9T, UL94V-0

Kontaktmaterial

Phosphorbronze

Kontaktoberfläche

Ni, Au / Sn

Kontaktwiderstand

40mΩ max

Isolationswiderstand

1000MΩ min

Strombelastbarkeit

1A

Betriebstemperatur

-10°C - +70°C

Prüfspannung

1000V AC

Verpackung

Stangenverpackung

Insulator material

PA9T, UL94V-0

Contact material

Phosphor bronze

Plating

Ni, Au / Sn

Contact resistance

40mΩ max

Insulation resistance

1000MΩ min

Current rating

1A

Operating temperature

-10°C - +70°C

Test voltage

1000V AC

Packing

Tube packing

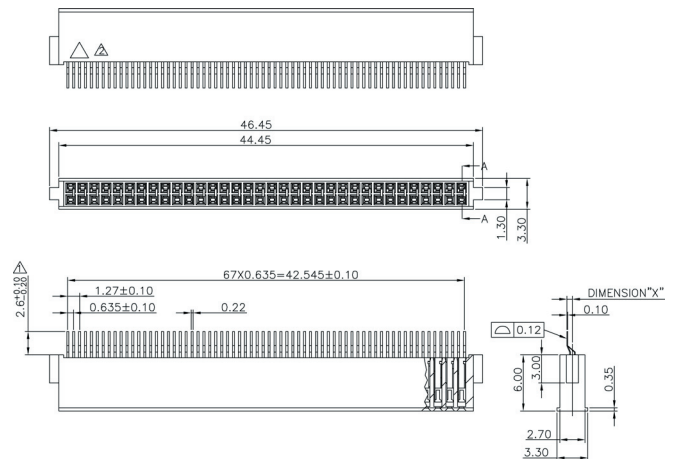
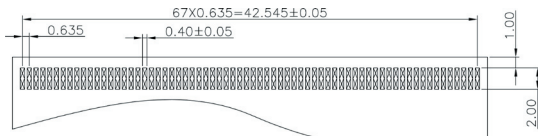

Bestellcode / Ordercode

Versatz Dim X

- 1 - 0.3mm
- 2 - 0.5mm
- 3 - 0.6mm
- 4 - 0.8mm
- 5 - 0.95mm

Offset Dim X

- 1 - 0.3mm
- 2 - 0.5mm
- 3 - 0.6mm
- 4 - 0.8mm
- 5 - 0.95mm

Oberfläche

- S - Gold flash (Selektiv)
- C - Gold 15µ" (Selektiv)

Contact plating

- S - Gold flash(selective)
- C - 15µ" gold (selective)

A - PCMCIA - 68 - F - x - x - 003

Bitte „x“ durch die geeignete Option ersetzen
Please replace „x“ with appropriate option

Cable assemblies

D-Sub / Hoods Centronics

Multiflex - DIN41651

Modular

USB IEEE1394

Switches

Powercords Powerlets

DIN41612 Hardmetric

MiniDIN

Sockets / Strips Jumper

Terminal Blocks

Memory Card

FFC / FPC

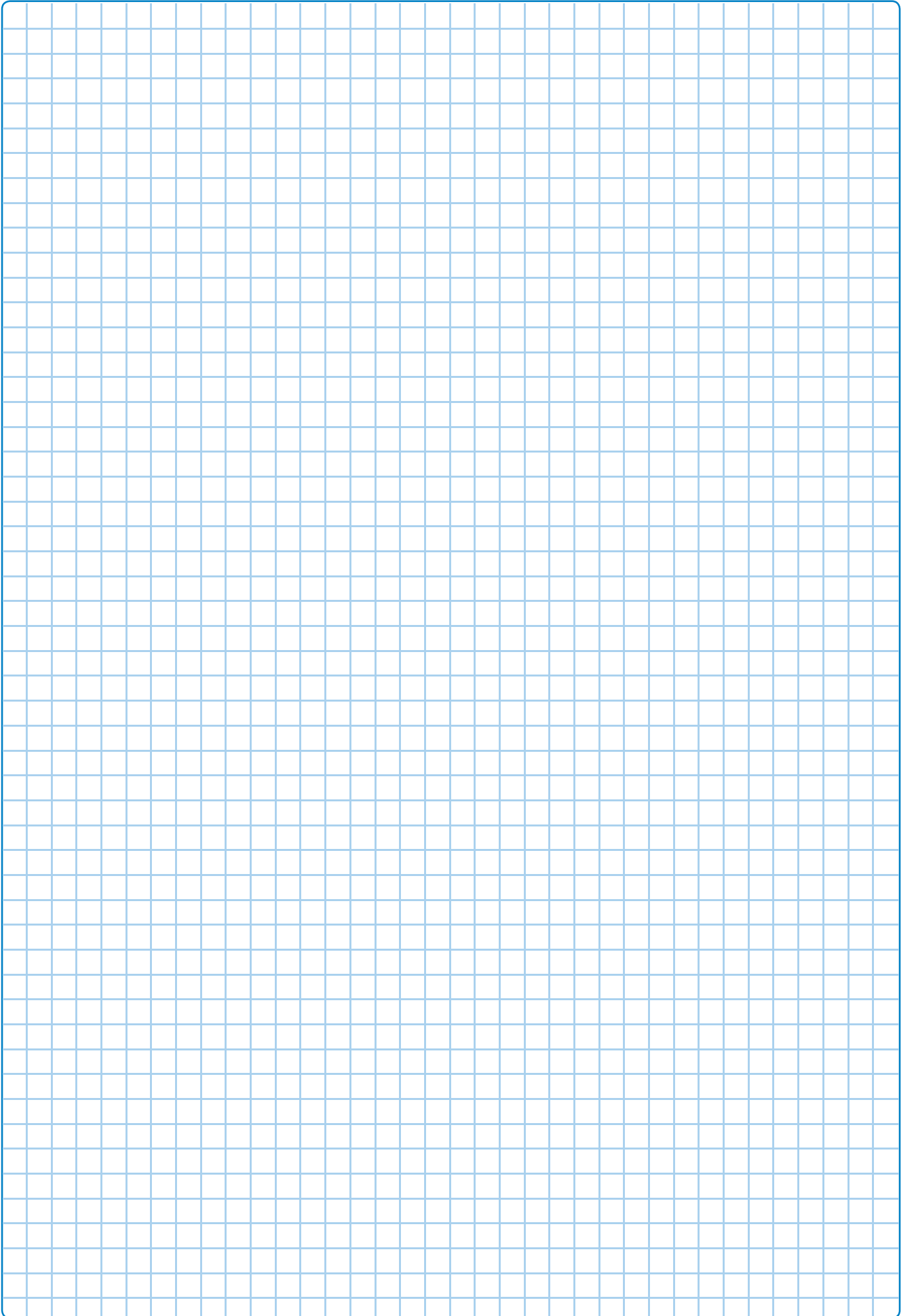

FFC / FPC

Memory Card

Terminal Blocks

Sockets / Strips
Jumper

MiniDIN

DIN41612
Hardmetric

Powercords
Powerinlets

Switches

USB
IEEE1394

Modular

Multiflex -
DIN41651

D-Sub / Hoods
Centronics

Cable
assemblies