

SMT COMMON MODE CHOKES

for PoE+ Applications



- RoHS-6 peak reflow temperature rating 245°C
- Meets IEEE 802.3 specification

Electrical Specifications @ 25°C — Operating Temperature 0°C to 70°C

Part Number ^{1,2,3}	SRF (TYP)	MAX Inter-winding Capacitance (pF)	Leakage Inductance (μH MAX)	OCL (±35%)	DC Resistance (Ω MAX)	Impedance Curves ⁴
H6500NL	110 MHz	8	0.12	15 μH	0.15	1
H6501NL	60 MHz	15	0.15	30 μH	0.20	2
H6502NL	42 MHz	18	0.20	60 μH	0.25	3
H6503NL	26 MHz	25	0.25	100 μH	0.30	4
H6504NL	7.0 MHz	10	0.20	250 μH	0.18	5
H6505NL	5.5 MHz	18	0.25	500 μH	0.28	6
H6506NL	2.6 MHz	30	0.30	1 mH	0.35	7
H6507NL	300 kHz	120	1.0	20 mH	1.50	8
H6508NL	150 kHz	160	1.5	40 mH	2.0	9

1. Turns Ratio: (1 - 4) : (5 - 8) = 1:1 (±3%)
2. Between channel isolation: 500 VAC @ 60 seconds
3. Polarity: per schematic
4. See charts page 2

Mechanicals

Schematic

H6500NL-H6506NL

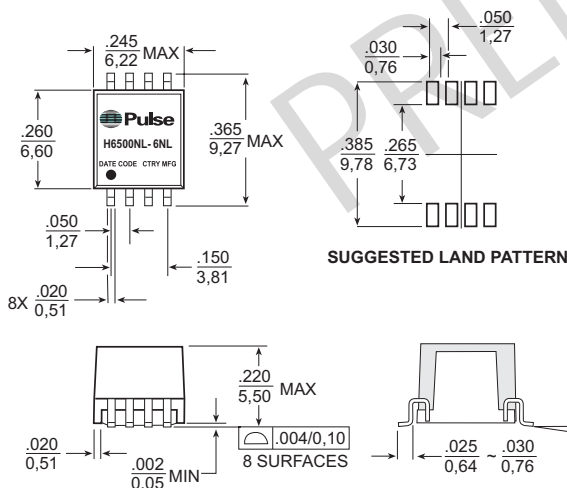

H6507NL & H6508NL

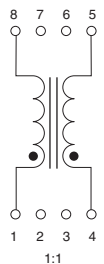
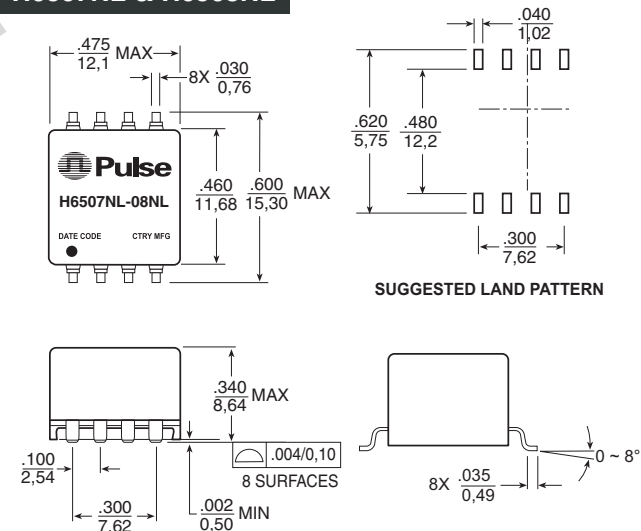

Weight0.4 grams
Tape & Reel750
Tube85

Dimensions: $\frac{\text{Inches}}{\text{mm}}$
Unless otherwise specified, all tolerances are $\pm \frac{.010}{0.25}$

Weight1.8grams
Tape & Reel250
Tube40

SMT COMMON MODE CHOKES for PoE+ Applications



Impedance Curves

H6500NL - H6506NL

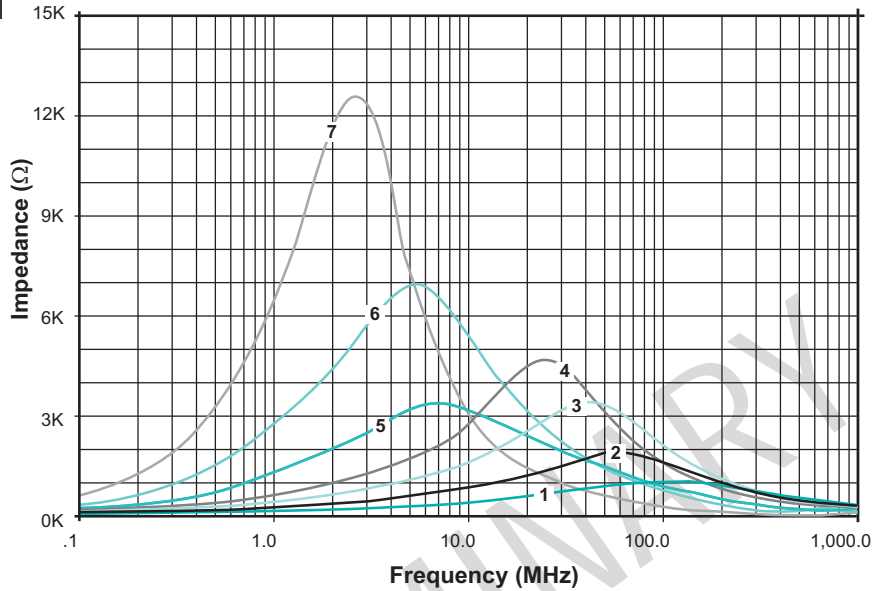

H6507NL & H6508NL

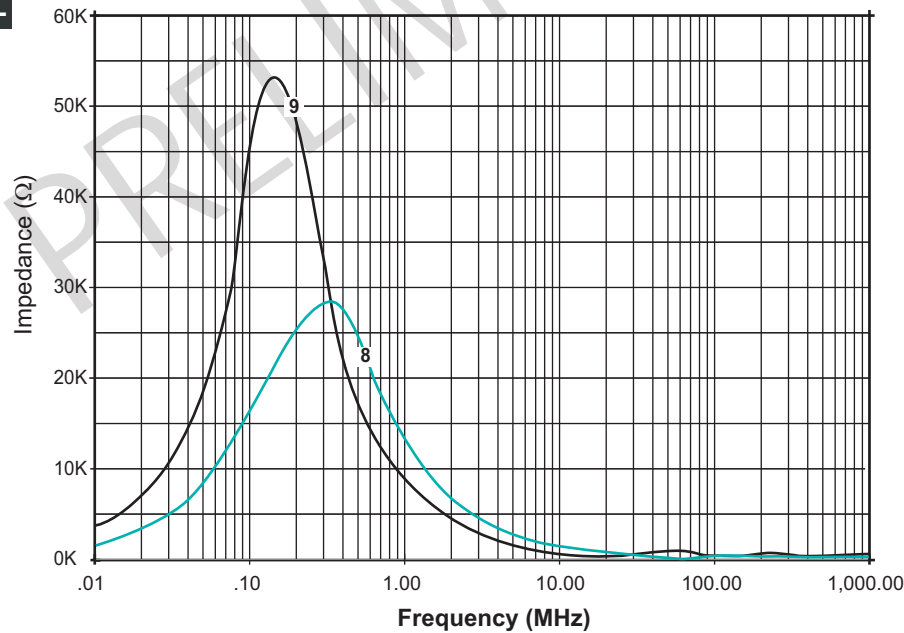

For More Information:

Pulse Worldwide Headquarters

12220 World Trade Dr.
San Diego, CA 92128
U.S.A.

www.pulseeng.com

TEL: 858 674 8100
FAX: 858 674 8262

Pulse European Headquarters

Einsteinstrasse 1
D-71083 Herrenberg
Germany

TEL: 49 7032 7806 0
FAX: 49 7032 7806 12

Pulse China Headquarters

B402, Shenzhen Academy of
Aerospace Technology Bldg.
10th Kejinan Rd.
High-Tech Zone
Nanshan District
Shenzhen, PR China 518057

TEL: 86 755 33966678
FAX: 86 755 33966700

Pulse North China

Room 1503
XinYin Building
No. 888 YiShan Rd.
Shanghai 200233
China

TEL: 86 21 32181071
FAX: 86 21 32181396

Pulse South Asia

150 Kampong Ampat
#07-01/02
KA Centre
Singapore 368324

TEL: 65 6287 8998
FAX: 65 6280 0080

Pulse North Asia

No. 26
Kao Ching Rd.
Yang Mei Chen
Taoyuan Hsien
Taiwan, R. O. C.
32667

TEL: 886 3 4643715
FAX: 886 3 4641911

Performance warranty of products offered on this data sheet is limited to the parameters specified. Data is subject to change without notice. Other brand and product names mentioned herein may be trademarks or registered trademarks of their respective owners.

© Copyright, 2008. Pulse Engineering, Inc. All rights reserved.