

# SMT GATE DRIVE TRANSFORMERS

## PA200xNL Basic and Operational Insulation



# Pulse

A TECHNITROL COMPANY

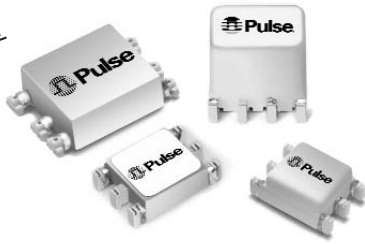

- Higher Volt- $\mu$ sec capability
- Basic insulation (1.4mm creepage/clearance) and operational available
- Operating frequency: 50kHz and up

### Electrical Specifications @ 25°C — Operating Temperature -40°C to 130°C<sup>5</sup>

Part <sup>3,4</sup> Number	Turns Ratio	Pri-Sec Insulation (V <sub>RMS</sub> )	MAX <sup>1</sup> V* $\mu$ sec	Primary Inductance ( $\mu$ H MIN)	Leakage <sup>2</sup> Inductance ( $\mu$ H MAX)	DCR Primary ( $\Omega$ MAX)	DCR Secondary ( $\Omega$ MAX)	Package Size (L x W x H) (mm MAX)
<b>OPERATIONAL INSULATION</b>								
PA2001NL	1:1	1500	12	403	0.46	0.60	0.60	8.6 x 6.7 x 2.5
PA2002NL	1:1:1	1500	60	1800	0.60	1.60	1.60	9.0 x 8.6 x 7.6
P02004NL	1:1:1	1500	16	437	0.85	0.85	0.85	8.6 x 6.7 x 3.6
<b>BASIC INSULATION (1.4 MM CREEPAGE AND CLEARANCE BETWEEN PRIMARY AND SECONDARY)</b>								
PA2005NL	1:1:1	1500	28	840	0.75	1.05	1.05	11.8 x 8.8 x 4.0
PA2006NL	1:1	1500	28	864	0.75	0.82	0.82	11.8 x 8.8 x 4.0
PA2007NL	1:1	1500	55.5	1490	0.80	1.15	1.15	9.0 x 8.6 x 7.6
PA2008NL	2:1:1	1500	55.5	1425	0.80	1.15	0.575	9.0 x 8.6 x 7.6
PA2009NL	2.5:1:1	1500	55.5	1486	0.80	1.15	0.425	9.0 x 8.6 x 7.6

#### NOTES:

- The maximum volt- $\mu$ sec rating limits the peak flux density to 2200 Gauss when used in a unipolar drive application. For bi-polar drive applications a maximum volt- $\mu$ sec of two times this rating is acceptable (ie: 2" volt\* $\mu$ sec rating) Volt\* $\mu$ sec = (voltage applied to the primary) \* dutycycle / Frequency = V \* alpha / Freq\_Hz = V \*  $\mu$ sec
- Leakage inductance is measured at primary terminals with all secondaries shorted.
- Optional Tape & Reel packaging can be ordered by adding a "T" suffix to the part number (i.e. PA2002NL becomes PA2002NLT). Pulse complies to industry standard tape and reel specification EIA481.
- The "NL" suffix indicates an RoHS-compliant part number.
- The temperature of the component (ambient plus temperature rise) must be within the stated operating temperature range.

### Mechanical

### Schematic

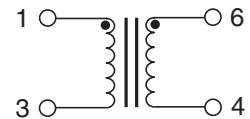
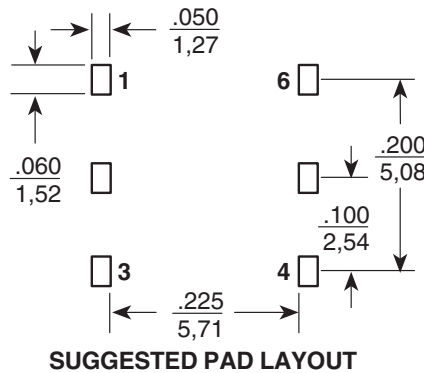
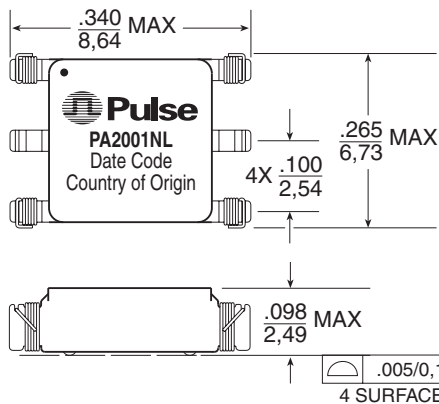

Weight .....0.28 grams  
Tape & Reel .....1500/reel  
Tube .....60/tube

Dimensions:  $\frac{\text{Inches}}{\text{mm}}$   
Unless otherwise specified,  
all tolerances are  $\pm \frac{.010}{0.25}$

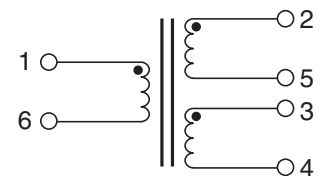
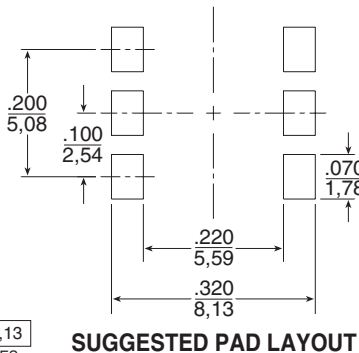
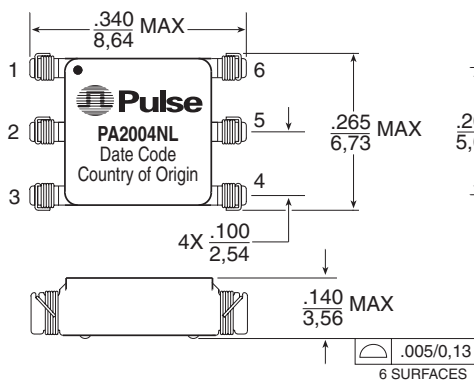

Weight .....0.23 grams  
Tape & Reel .....800/reel  
Tube .....75/tube

Dimensions:  $\frac{\text{Inches}}{\text{mm}}$   
Unless otherwise specified,  
all tolerances are  $\pm \frac{.010}{0.25}$

# SMT GATE DRIVE TRANSFORMERS

## PA200xNL Basic and Operational Insulation



### Mechanicals

### Schematics

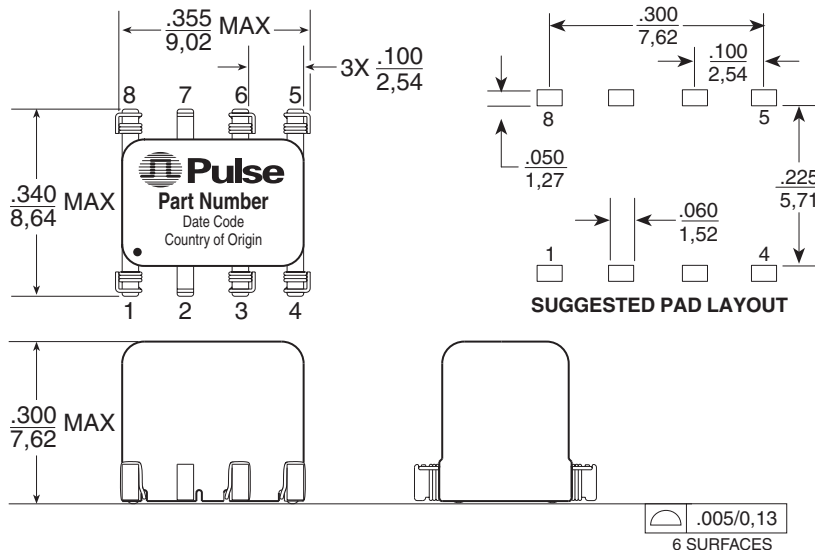

PA2002NL / PA2008NL / PA2009NL

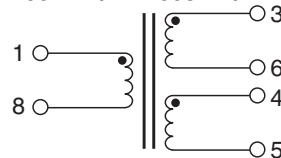

PA2007NL



Weight ..... .060 grams  
 Tape & Reel ..... .400/reel  
 Tube ..... .50/tube

Dimensions:  $\frac{\text{Inches}}{\text{mm}}$

Unless otherwise specified, all tolerances are  $\pm \frac{.010}{0.25}$

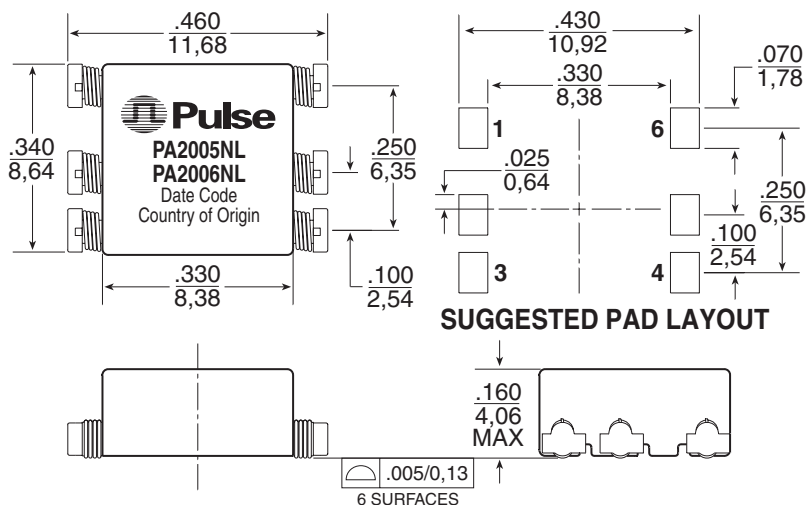

PA2005NL

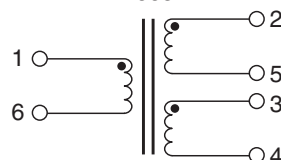

PA2006NL



Weight ..... .048 grams  
 Tape & Reel ..... .900/reel  
 Tube ..... .60/tube

Dimensions:  $\frac{\text{Inches}}{\text{mm}}$

Unless otherwise specified, all tolerances are  $\pm \frac{.010}{0.25}$

### For More Information:

#### Pulse Worldwide Headquarters

12220 World Trade Dr.  
 San Diego, CA 92128  
 U.S.A.  
[www.pulseeng.com](http://www.pulseeng.com)

#### Pulse Europe

Einsteinstrasse 1  
 D-71083 Herrenberg  
 Germany

#### Pulse China Headquarters

B402, Shenzhen  
 Tech-Innovation International  
 Tenth Kejinan Rd.  
 High-Tech Industrial Park  
 Nanshan District, Shenzhen  
 China

#### Pulse North China

Room 1503  
 XinYin Building  
 No. 888 YiShan Rd.  
 Shanghai 200233  
 China

#### Pulse South Asia

150 Kampong Ampat  
 #07-01/02  
 KA Centre  
 Singapore 368324

#### Pulse North Asia

No. 26  
 Kao Ching Rd.  
 Yang Mei Chen  
 Tao Yuan Hsien  
 Taiwan, R. O. C.

Tel: 858 674 8100

Tel: 49 7032 7806 0

Tel: 86 755 33966678

Tel: 86 21 54643211/2

Tel: 65 6287 8998

Tel: 886 3 4641811

Fax: 858 674 8262

Fax: 49 7032 7806 12

Fax: 86 755 33966700

Fax: 86 21 54643210

Fax: 65 6280 0080

Fax: 886 3 4641911

Performance warranty of products offered on this data sheet is limited to the parameters specified. Data is subject to change without notice. Other brand and product names mentioned herein may be trademarks or registered trademarks of their respective owners. © Copyright, 2007. Pulse Engineering, Inc. All rights reserved.