

RoHS  **SL1021A/B, SL1024A/B and PMT8 Series**



Description

GDT circuit protection devices dissipate electrical surge energy safely within a contained plasma gas. Commonly used to help protect sensitive telecom and networking equipment and lines, GDTs protect from damage that may result from lightning strikes and equipment switching operations.

The Littelfuse GDT series described in this document are available in a variety of leaded and surface mount forms and offered with and without optional fail-safe clip. Please refer to the electrical specifications, dimension and packaging options section of this document for additional information.

SL1021A/B and SL1024A/B Series:

SL1021A/B and SL1024A/B series GDTs are designed to offer high levels of performance on fast rising transients in the range of 100V/μS to 1KV/μS, which are those most likely created by induced lightning disturbances.

These devices feature ultra low capacitance (typically 1.5pF or less) and are extremely robust with SL102xA devices able to divert a 10,000 Amp pulse without destruction, and SL102xB suffix devices able to divert a 20,000 Amp pulse without destruction.

These series offer optimized internal geometry which provide low insertion loss at high frequencies, ideal for the protection of broadband and other high speed transmission equipment.

PMT8 Series:

PMT8 GDT's are telecom grade devices designed to meet the recommendations in CCITT-K12 and Bellcore GR-1361-CORE. The three electrode configuration is used in applications where simultaneous crowbar action of two signal lines is required.

Agency Approvals

| AGENCY | AGENCY FILE NUMBER |
|---|--------------------|
|  | E128662 |

3 Electrode GDT Graphical Symbol

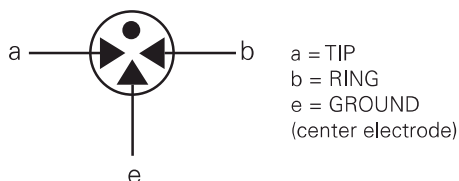

Features

- RoHS compliant
- Low insertion loss
- Excellent response to fast rising transients
- Ultra low capacitance
- 10KA (A suffix devices) / 20KA (B suffix devices) surge capability tested with 8/20μs pulse as defined by IEC 61000-4-5
- Available with thermal failsafe option (add 'F' suffix to part number)

Applications

SL1021 / SL1024:

- Broadband equipment
- ADSL equipment
- XDSL equipment
- Satellite and CATV equipment
- Splitters
- General telecom equipment

PMT8:

- Telecom network interfaces
- Telephone line cards
- Repeaters
- Modems
- Line test equipment

Product Characteristics

| | |
|--|---|
| Materials | Dull Tin Plate 17.5 ± 12.5 Microns. with ceramic insulator |
| Product Marking | 'LF' mark, voltage & date code: SL102xA - Red/White text SL102xB & PMT8 - Blue/White text |
| Glow to arc transition current | ~ 1Amp |
| Glow Voltage | ~60-200 Volts |
| Storage and Operation Temperature | -40 to +90°C |
| Transverse Voltage (Delay Time) | < 0.2μSec (Tested to ITU-T Rec. K.12) |
| Arc Voltage | ~10 to 35 Volts |
| Holdover Voltage | <150mS (Tested to ITU-T Rec. K.12) |

Electrical Characteristics

| Device Specifications (at 25°C) | | | | | | | Life Ratings | | | | | |
|---|----------------------|-----|-----|------------------------|----------------------|---------------------|------------------------------|---------------------------------------|---|--|--|--|
| Part Number* | DC Voltage 100V/Sec. | | | DC Voltage 100 V/μSec. | DC Voltage 1kV/μSec. | Capacitance (@1MHz) | Insulation Resistance | AC Current 50Hz 1Sec.x10 ¹ | Surge Current 8/20μSec x10 ¹ | Max Single Surge 8/20μSec ¹ | Max Single Surge 10/350μSec ¹ | Surge Life 10/1000 μSecx300 ¹ |
| | MIN | TYP | MAX | | | | | | | | | |
| SL1021A090 SL1024A090 SL1021B090 SL1024B090 PMT 8 090 | 72 | 90 | 108 | 500 | 650 | <1.5pF | >10 ¹⁰ Ω (at 50V) | 10Amps | 10kA ² 20kA ³ | 15kA ² 25kA ³ | 4kA ² 5kA ³ | 200Amps |
| SL1021A145 SL1024A145 SL1021B145 SL1024B145 | 116 | 145 | 174 | | | | | | | | | |
| SL1021A150 SL1024A150 SL1021B150 SL1024B150 | 120 | 150 | 180 | | | | | | | | | |
| SL1021A200 | 150 | 200 | 250 | | | | | | | | | |
| SL1021A230 SL1024A230 SL1021B230 SL1024B230 PMT 8 230 | 184 | 230 | 276 | 450 | 650 | | | | | | | |
| SL1021A250 SL1024A250 SL1021B250 SL1024B250 PMT 8 250 | 200 | 250 | 300 | 500 | | | | | | | | |
| SL1021A260 SL1024A260 SL1021B260 SL1024B260 | 210 | 260 | 310 | 550 | 700 | | | | | | | |
| SL1021A300 SL1024A300 SL1021B300 SL1024B300 | 240 | 300 | 360 | 650 | 850 | | | | | | | |
| SL1021A350 SL1024A350 SL1021B350 SL1024B350 PMT 8 350 | 280 | 350 | 420 | 700 | 900 | | | | | | | |
| SL1021A400 SL1024A400 SL1021B400 SL1024B400 PMT 8 400 | 320 | 400 | 480 | 850 | 950 | | | | | | | |
| SL1021A420 SL1024A420 SL1021B420 SL1024B420 | 345 | 420 | 500 | | | | | | | | | |
| SL1021A450 SL1024A450 SL1021B450 SL1024B450 | 360 | 450 | 540 | 900 | 1000 | | | | | | | |
| SL1021A500 SL1024A500 SL1021B500 SL1024B500 | 400 | 500 | 600 | 950 | 1100 | | | | | | | |
| SL1021A600 SL1024A600 | 480 | 600 | 720 | 1000 | 1200 | | | | | | | |

NOTES:

*Max capacitance is 1.5 pF measured at 1 MHz.

1. Total current through centre electrode, tested in accordance with ITU-T Rec K.12
2. SL A series
3. SL B series & PMT 8 series

Time vs. Current for Failsafe

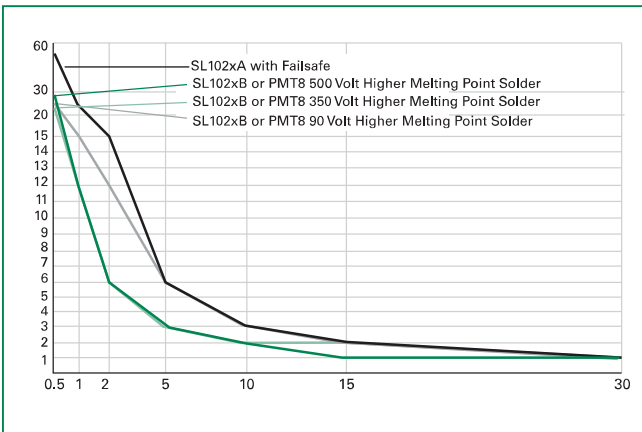

Voltage vs. Time Characteristic

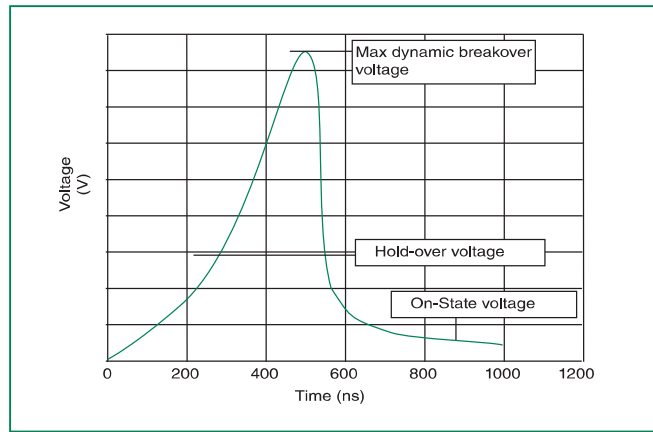

Soldering Parameters - Reflow Soldering (Surface Mount Devices)

| | | |
|--|------------------------------------|-------------------------|
| Reflow Condition | Pb - Free assembly | |
| Pre Heat | - Temperature Min ($T_{s(min)}$) | 150°C |
| | - Temperature Max ($T_{s(max)}$) | 200°C |
| | - Time (Min to Max) (t_s) | 60 - 180 secs |
| Average ramp up rate (Liquidus Temp (T_L) to peak) | | 3°C/second max |
| $T_{s(max)}$ to T_L - Ramp-up Rate | | 5°C/second max |
| Reflow | - Temperature (T_L) (Liquidus) | 217°C |
| | - Temperature (t_L) | 60 - 150 seconds |
| Peak Temperature (T_p) | | 260 ^{+0/-5} °C |
| Time within 5°C of actual peak Temperature (t_p) | | 10 - 30 seconds |
| Ramp-down Rate | | 6°C/second max |
| Time 25°C to peak Temperature (T_p) | | 8 minutes Max. |
| Do not exceed | | 260°C |

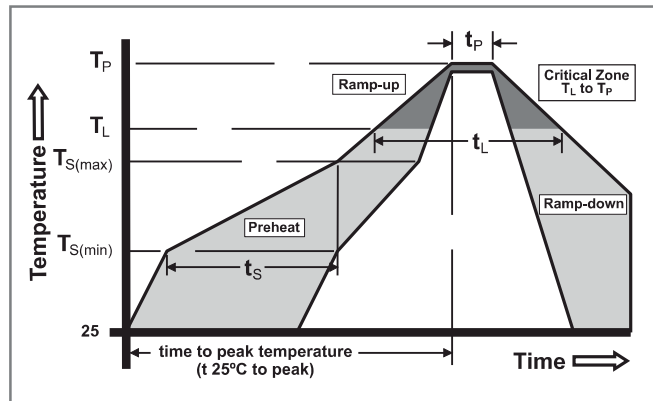

Soldering Parameters - Hand Soldering

Solder Iron Temperature: 350° C +/- 5° C
 Heating Time: 5 seconds max.

Soldering Parameters - Wave Soldering (Thru-Hole Devices)

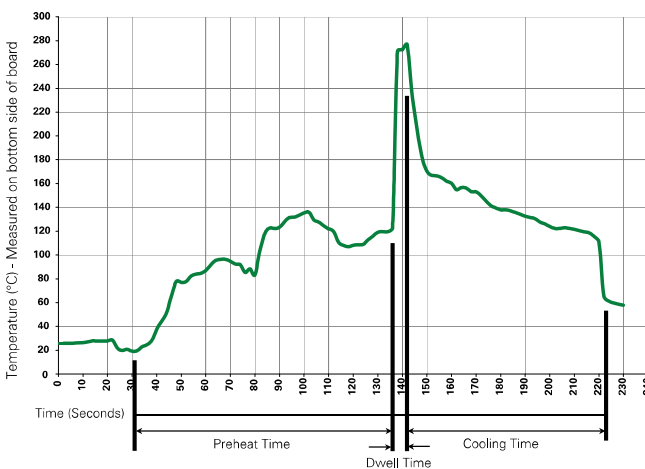

Recommended Process Parameters:

| Wave Parameter | Lead-Free Recommendation |
|---|--------------------------|
| Preheat: (Depends on Flux Activation Temperature) (Typical Industry Recommendation) | |
| Temperature Minimum: | 100° C |
| Temperature Maximum: | 150° C |
| Preheat Time: | 60-180 seconds |
| Solder Pot Temperature: | 280° C Maximum |
| Solder Dwell Time: | 2-5 seconds |

Note: Surge Arrestors with a Failsafe mechanism should be individually examined after soldering

Device Dimensions

NOTE: Failsafe option dimensions shown in green.

Shaped Radial Ledged Devices:

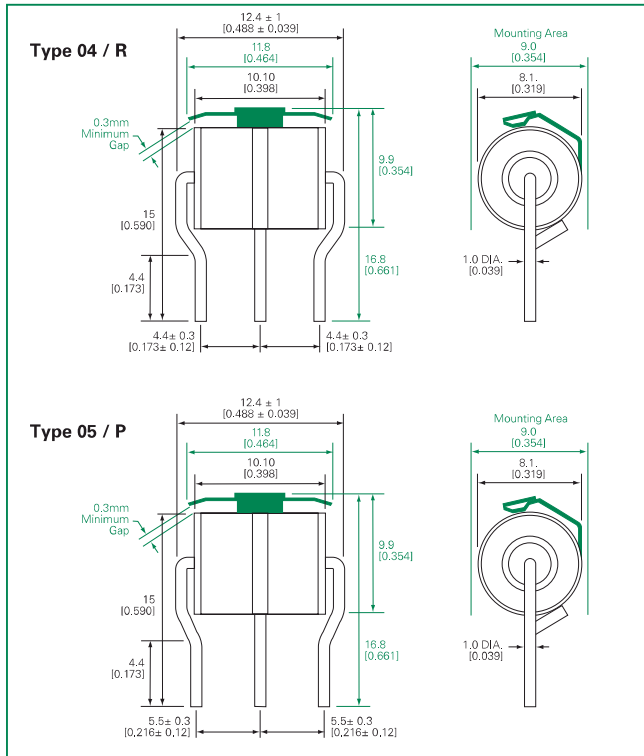

Surface Mount Devices:

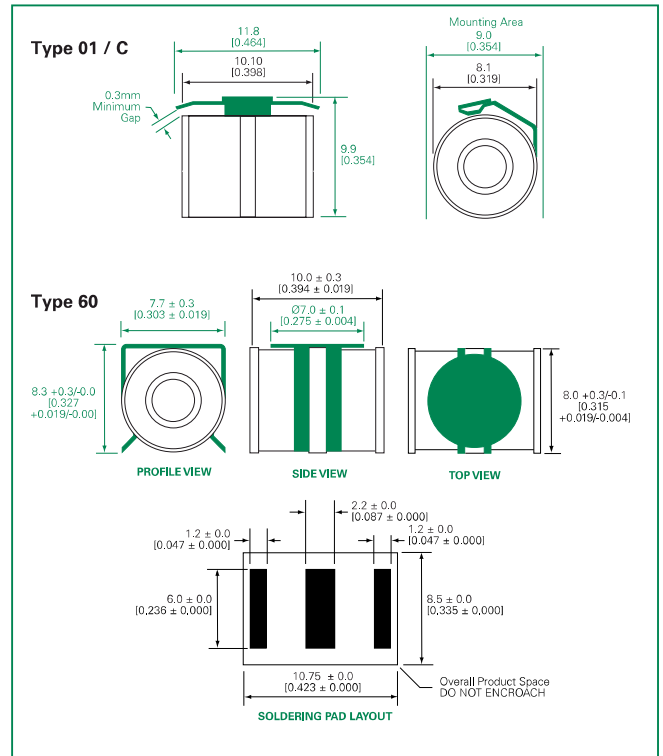

Straight "T" Ledged Devices:

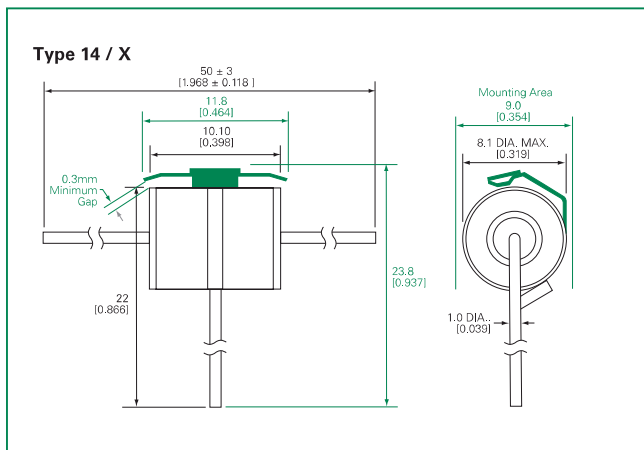

Straight Radial Ledged Devices:

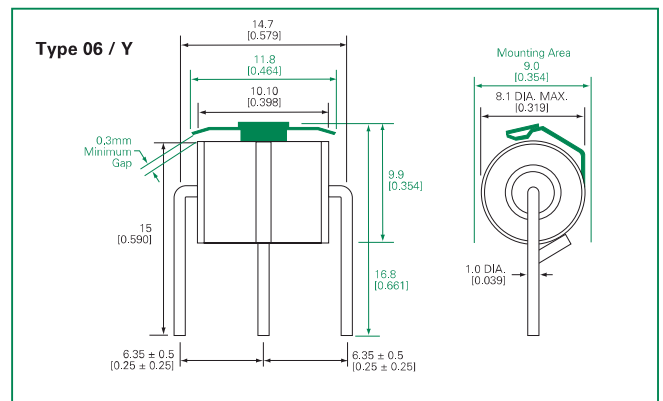



Part Numbering System and Ordering Information

SL102x x xxx x x

Series _____
 SL1021
 SL1024

Surge Capability _____
 A = 10kA
 B = 20kA

Breakdown Voltage _____
 090 = 90V 300 = 300V
 145 = 145V 350 = 350V
 150 = 150V 400 = 400V
 200 = 200V 420 = 420V
 230 = 230V 450 = 450V
 250 = 250V 500 = 500V
 260 = 260V 600 = 600V

Configuration Code _____
 (See Device Dimensions section)
 C Y
 R X
 P

Option Code _____
 Blank = No failsafe
 F or G = With Failsafe

PMT8 xxx x x

Series _____
 PMT8

Breakdown Voltage _____
 090 = 90V
 230 = 230V
 250 = 250V
 350 = 350V
 400 = 400V

Configuration Code _____
 (See Device Dimensions section)
 01 10
 04 14
 05 60
 06

Option Code _____
 Blank = No Failsafe
 F = With Failsafe

Packaging

| Device Type | Description | Quantity |
|-------------|------------------------------------|----------|
| Type 01 / C | 100pcs/tray x 5 trays per carton | 500 |
| Type 04 / R | 100pcs/tray x 5 trays per carton | 500 |
| Type 05 / P | 100pcs/tray x 5 trays per carton | 500 |
| Type 06 / Y | 100pcs/tray x 5 trays per carton | 500 |
| Type 14 / X | 50pcs/tray x 5 trays per carton | 250 |
| Type 60 | 500pcs/reel* x 10 reels per carton | 5000 |

* For tape and reel specifications, please contact factory.