

PRODUCT COMPOSITION

Index	Modifications	Drawn by	Checked	Date
B	Creation	A.Landomiel	***	13/02/2013

1. 4 parallel pairs (a-PTFE AWG27 MaE 2)
Conductor

Material: Silver Plated Copper
Composition: AWG27 or 7x0.142 mm nom.
Diameter: 0.42 mm nom.
Section: 0.11mm² nom.
Resistance: 17 Ohms/100m nom. @ 20°C

Insulation

Material: Extruded alveolar PTFE
Diameter : 0.95 mm nom.
Colours : white green, white/brown,
white/blue, white/orange

2. Shield

Material: aluminium/polyester tape

3. Separative PTFE tape

4. Outer jacket:

Material: laminated composite ePTFE tape
Colour: white

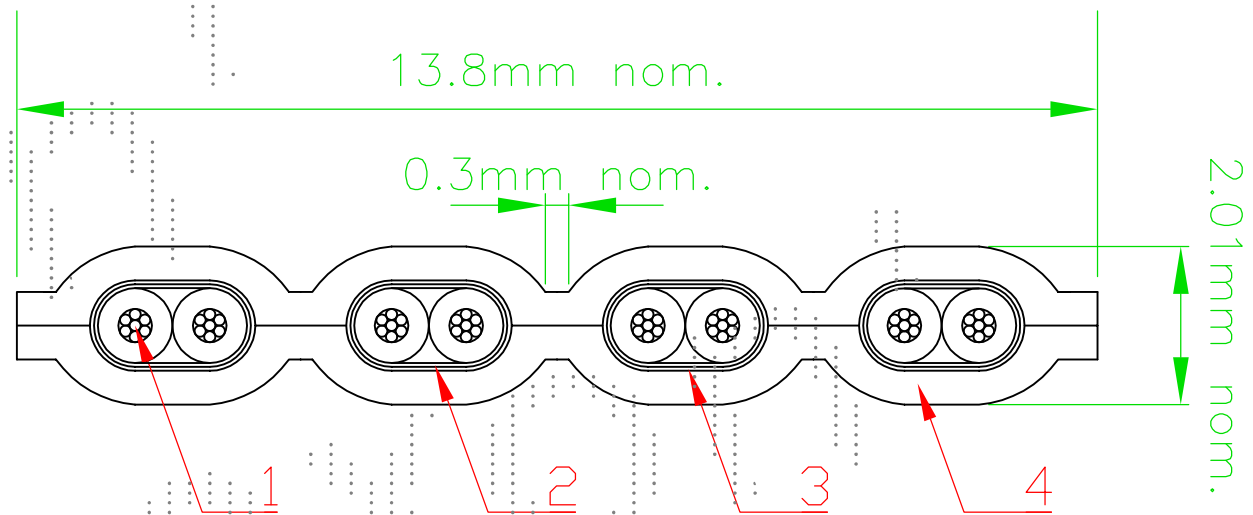

MAIN CHARACTERISTICS

Approximative weight : 55 g/m
Temperature rating : -40°C/+90°C
Impedance : 100Ω nom.
Dynamic bending radius : 20,1 mm

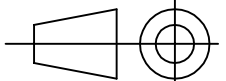
UNLESS OTHERWISE SPECIFIED		 axon' KABEL & VERBINDUNGSSYSTEME	AXON' KABEL GmbH POSTFACH 1131 - D-71201 LEONBERG HERTICHSTR. 10 - D-71229 LEONBERG TEL : +49 7152-97992-0 FAX : +49 7152-97992-7 E-Mail : sales@axon-cable.de	
DIMENSIONS ± MM	ANGLES ± DEGREE		Customer N° : *****	Title : Flextrack F Ethernet AWG27 (parallel pairs)
File N° : SF12452B.dwg		Size A4	AXON' GmbH N° : SF12452	
		Scale : N.D.	Sheet 1/1	