

REV.	DESCR. MODIFICA / REVISIONS DESCRIPTION	DATA/DATE DIS./DWN
0.0		Luca Biasio 10-May-13 05:15:13 PM

ETICHETTA
LABEL

NASTRO ADESIVO
ADHESIVE TAPE

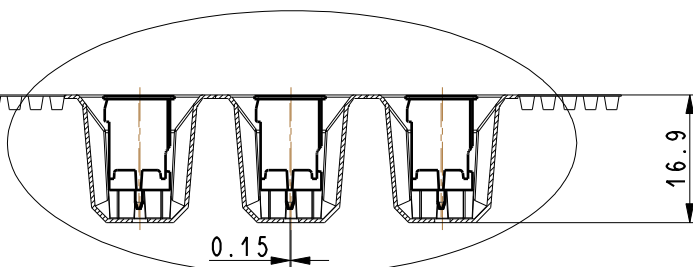
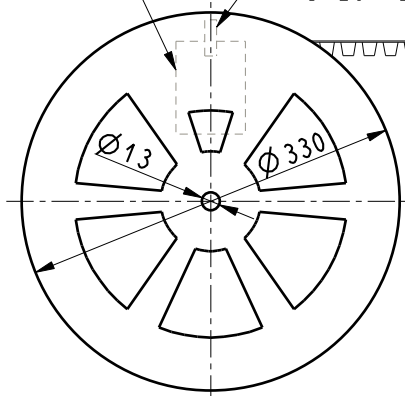

FORI CILINDRICI
SPROCKET HOLES

AREA PER PRELIEVO
PICK & PLACE PAD AREA

SCALA 1.000

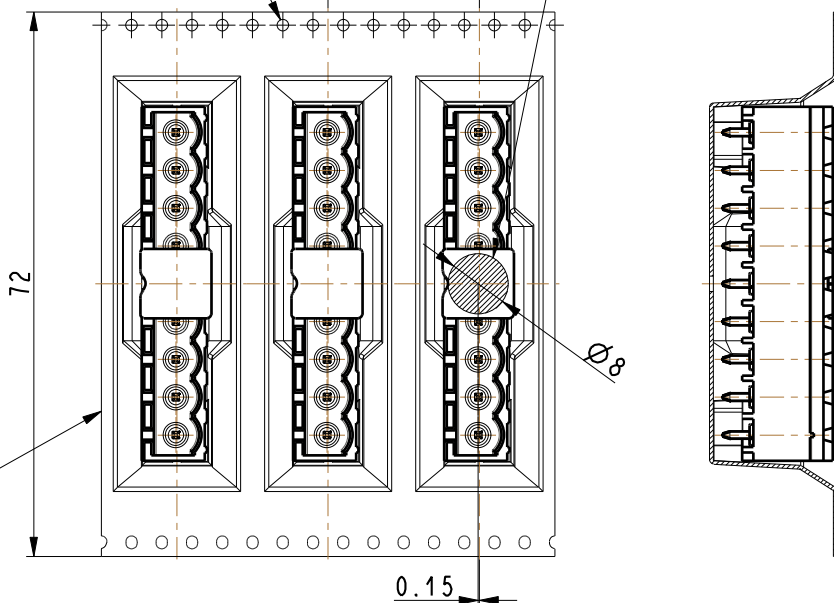

TAPE DISEGNO: S19-00-160
TAPE DRAWING: S19-00-160
COD. TAPE: WICIM72D1
TAPE P/N: WICIM72D1

p/n CIMH090P1-OG
Q.ty: 192 pcs/reel

Note per la produzione:
-Codice in distinta
CIMH090P1-OG00N
-Quantità: 192 pz/bobina

NOTE CONFEZIONAMENTO:
* CONFEZIONE SECONDO
"IPC/JEDEC J-STD-033"
-Sacchetto a barriera di umidità
-Indicatore livello di umidità
-Sacchetto argilla disidratante
-Foglio informativo
Moisture-Sensitive-Devices

PACKAGING NOTES:
* PACKAGING ACCORDING TO
"IPC/JEDEC J-STD-033"
-Moisture barrier bag
-Humidity indicator
-Desiccant bag
-Moisture-Sensitive-Devices
information sheet

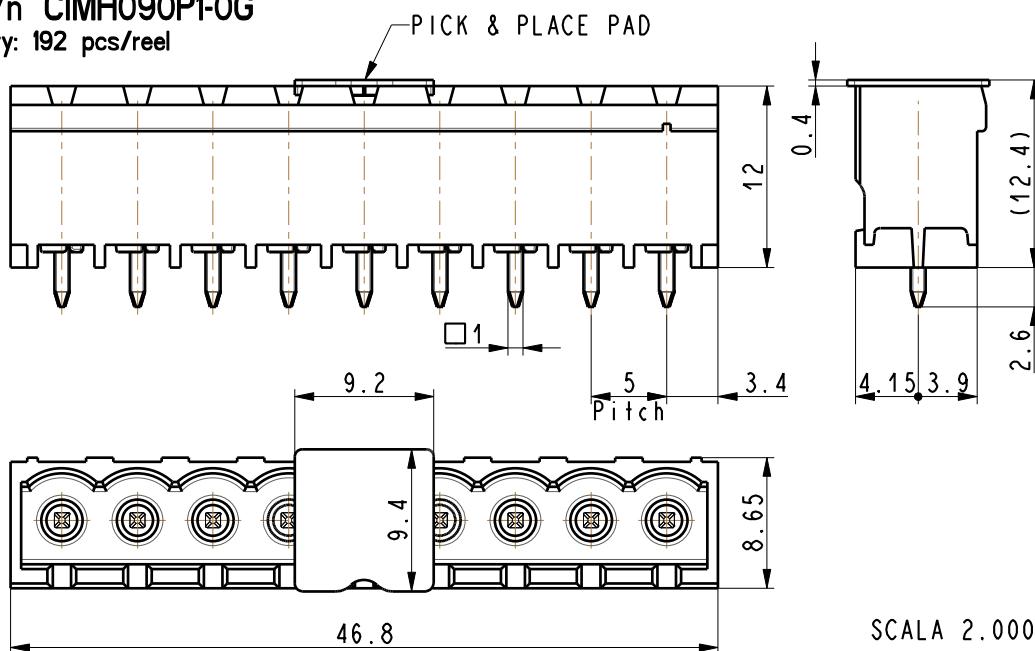

SCALA 2.000

CODICE
PN

KC IMH090P1TG

KIT:	-	PASSO/PITCH:	-
FOGLIO/SHEET:	DIS. N° / DRAW. N°:	FIRMA/SIGNATURE:	DATA/DATE:
1 / 1	KC IMH090P1TG	Biasio	10-May-13

