

SMT POWER INDUCTORS

Wirewound - PD0120 Series



- Height:** 8.2mm Max
- Footprint:** 16.2mm x 16.0mm Max
- Current Rating:** up to 15.4A
- Inductance Range:** 1.2μH to 55.4μH

Electrical Specifications @ 25°C — Operating Temperature -40°C to +125°C⁶

Part Number	Inductance @ I _{rated} (μH ±10%)	I _{rated} ¹ (A _{DC})	DCR (mΩ)		Inductance @ 0 A _{DC} (μH ±10%)	Saturation Current ² (A)		Heating Current ³ (A)	Core Loss Factor ⁴ Kc
			TYP	MAX		25°C	100°C		
PD0120.102	1.2	15.4	1.5	2.0	1.2	29	24.6	15.4	5556
PD0120.152	1.8	14.2	2.5	3.0	1.8	24.3	19	14.2	4444
PD0120.222	2.5	11.4	4.0	4.2	2.6	20.6	17.6	11.4	3704
PD0120.332	4.5	11.2	6.3	6.8	4.6	15	13	11.2	2778
PD0120.532	5.6	10.4	8.0	8.5	5.7	13.6	11.6	10.4	2469
PD0120.702	7.1	8.6	9.5	10.0	7.2	12.6	10.6	8.6	2222
PD0120.113	12.0	7.6	15.0	16.0	12.2	9	8	7.6	1709
PD0120.183	18.3	6.4	21.5	25.5	18.7	7.6	6.6	6.4	1389
PD0120.223	22.6	5.3	30.5	35.5	23.1	6.8	6	5.3	1235
PD0120.373	39.9	4	51.5	58.5	40.7	5	4.6	4	926
PD0120.503	55.4	3.4	75.5	82.5	56.5	4.3	3.8	3.4	794

NOTE: To order RoHS compliant part, add the suffix "NL" to the part number (i.e. PD0120.102 becomes PD0120.102 NL).

Mechanical

Schematic

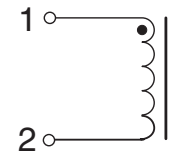
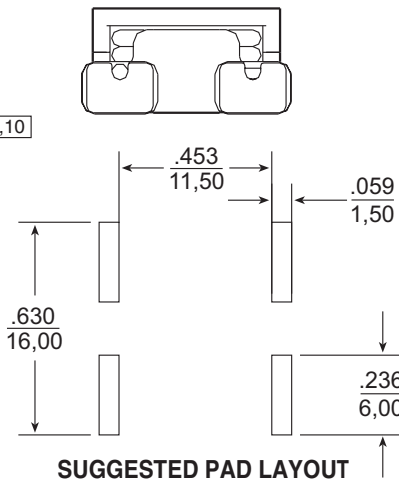
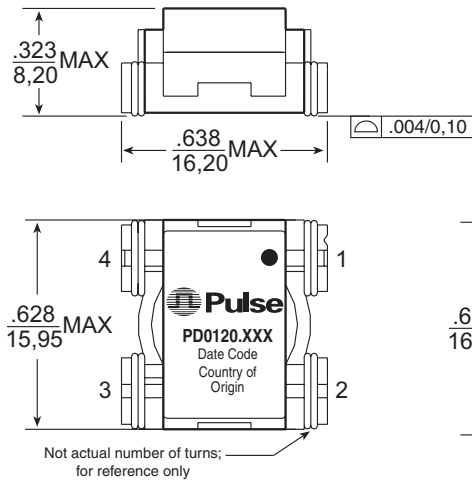

Weight 4.25 grams
Tape & Reel250/reel

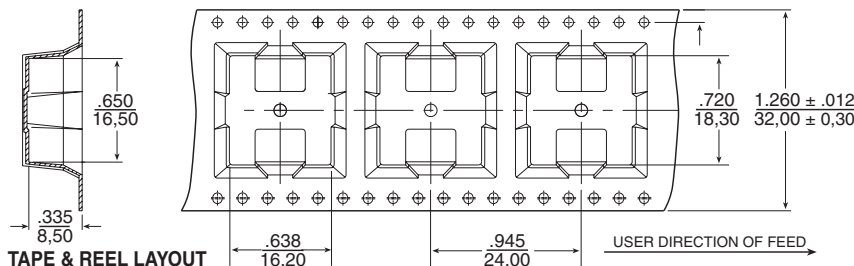

Dimensions: Inches
mm
Unless otherwise specified,
all tolerances are ± .010
0,25

Notes from Tables

1. The rated current as listed is either the saturation current or the heating current depending on which value is lower.
2. The saturation current is the current which causes the inductance to drop by 10% at the stated ambient temperatures (-40°C, 25°C and 125°C). This current is determined by placing the component in the specified ambient environment and applying a short duration pulse current (to eliminate self-heating effects) to the component.
3. The heating current is the DC current which causes the temperature of the part to increase by approximately 45°C. This current is determined by mounting the component on a PCB with .25" wide, 3 oz. equivalent copper traces, and applying the current to the device for 30 minutes with no forced air cooling.
4. In high volt*time applications, additional heating in the component can occur due to losses in the inductor which may necessitate derating the current in order to limit the temperature rise of the component. In order to determine the approximate total losses (or temperature rise) for a given application both copper losses and core losses should be taken into account.
5. Optional Tape & Reel packaging can be ordered by adding a "T" suffix to the part number (i.e. PD0120.102 becomes PD0120.102T). Pulse complies to industry standard tape and reel specification EIA481.

Estimated Temperature Rise:

$$Trise = \left[\frac{Coreloss (mW) + DCRloss (mW)}{7.05} \right]^{.833} (^\circ C)$$

$$Coreloss = 1.86E-12 * (Freq (kHz))^{1.63} * (Kc * V\mu sec)^{2.17} (mW)$$

$$DCRloss = I_{rms}^2 * DCR(m\Omega) (mW)$$

$$I_{rms} = \left[I_{DC}^2 + \left[\frac{dI}{12} \right]^2 \right]^{1/2} (Arms)$$

$$Freq (kHz) = \text{switching frequency (kHz)}$$

$$V\mu sec = L (\mu H) * dI_{or} V * D * 1000 / Freq (kHz)$$

$$dI = pk - pk \text{ ripple current across the component (A)}$$

$$V = \text{Voltage across the component (V)}$$

$$D = \text{Duty cycle}$$

6. The temperature of the component (ambient plus temperature rise) must be within the stated operating temperature range.

Inductance vs Current Characteristics

