

# PSZ-1002

## Heatsink-Set

*Heatsink set*

- 1x Heatsink
- 1x Thermal-Pad
- 4x Schraube / Federscheibe

- 1x Heatsink
- 1x Thermal pad
- 4x Screw / Washer



### Gehäuse-Zeichnung PSZ-1002 / Drawing PSZ-1002

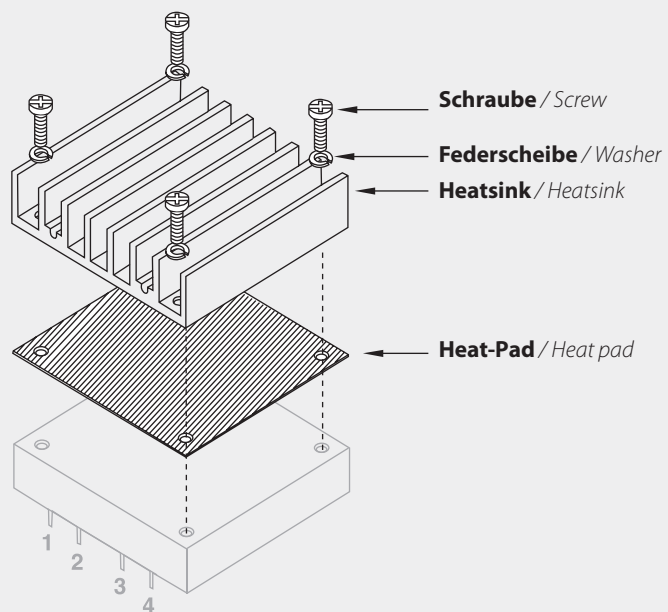
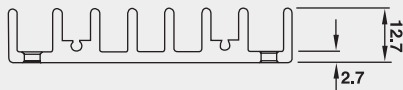
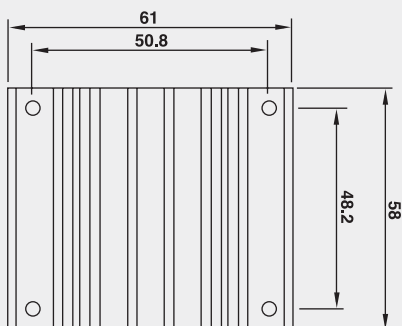

#### Rca

- 4.70°C/W (typ.), At natural convection
- 2.89°C/W (typ.), At 100LFM
- 2.30°C/W (typ.), At 200LFM
- 1.88°C/W (typ.), At 300LFM
- 1.59°C/W (typ.), At 400LFM