

# User Manual

LSUM 016R2C 0500F EA

## History

Version	Date	Change Description	Author
V0	Jun. 09. 2014	First version	SW Son
V1	Apr. 02. 2015	Change the picture in 10page.(connector)	SW Son
V2	Nov. 26. 2021	New format	SH Kim

## CONTENTS

<b>1. Overview</b>	.....	<b>04</b>
<b>2. Identification of features</b>	.....	<b>05</b>
<b>3. Unpacking</b>	.....	<b>06</b>
<b>4. Safety</b>	.....	<b>06</b>
<b>5. Module to module connection</b>	.....	<b>07</b>
<b>6. Output terminal connection</b>	.....	<b>08</b>
<b>7. Output connector</b>	.....	<b>08</b>
<b>8. Mounting</b>	.....	<b>11</b>
<b>9. Maintenance</b>	.....	<b>12</b>
<b>Appendix I</b>	.....	<b>13</b>
<b>Appendix II</b>	.....	<b>14</b>

## 1. Overview

The LS 16.2V / 500F Ultracapacitor Module has high energy and low ESR to meet energy storage and power delivery requirements.

The cells used in the module have 2.7 V maximum voltage rating and are connected in series to get higher operating voltage of modules. To meet the long cycle life requirements, the cells operate under 2.7 V. In addition, all the cells are balanced by balancing circuit connected parallel to each cell.

## 2. Identification of features



<MH01, MH02>



<MH03, MH04>

### 3. Unpacking

Inspect the shipping carton for signs of damage prior to unpacking the module. Damage to the shipping carton or module should be reported to the carrier immediately.

Remove the module from the shipping carton and retain the shipping materials until the unit has been inspected and is determined to be operational.

**NOTE:** The original shipping materials are approved for both air and ground shipment. The module should be removed from the shipping carton by lifting the body of the module.

### 4. Safety

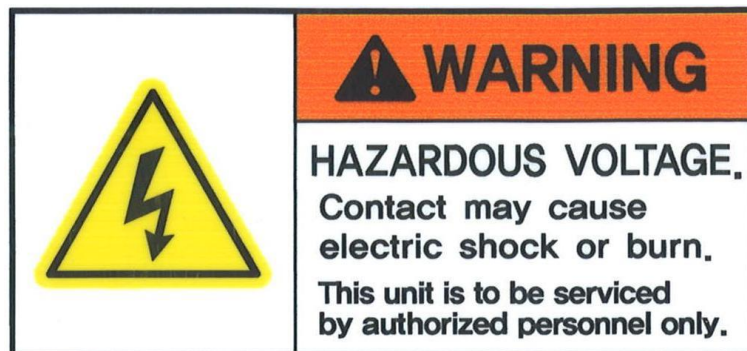

- Do not operate above specified voltage.
- Do not operate above specified temperature rating.
- Do not touch terminals with conductors while charged. Serious burns, shock, or material fusing may occur.
- Protect surrounding electrical components from incidental contact.
- Provide sufficient electrical isolation when working above rated voltage.
- Prior to installation and removal from the equipment, it is mandatory to fully discharge the module.

### 5. Module to module connection

- There are series and parallel connection for High power



<Fig. 2> Series Connection of Modules



<Fig. 3> Parallel Connection of Modules.

## 6. Output terminal connection

The LS 16.2V / 500F Ultracapacitor Modules are designed to connect directly to a ring or a bus bar. The positive and negative terminals have each hole for the screw. The positive terminal threaded size is M8 and negative terminal is M10. Wave washers are required to ensure long term, reliable connections.

When tightening the terminal bolt, a torque of 20 N-m for the M8 bolt should be used.(30N-m for the M10 bolt) Because the modules have a very low ESR, total ESR will be affected by a ring lug, bus bar or torque. Therefore, it needs more attention to assemble the modules. And appropriate protection and sealing should be used on both module terminals to avoid shock hazards and corrosion.

## 7. Output connector

- The output of connector is tabulated below.

Pin #	Wire color	Pin out	Signal
1	Red	TEMP	Pin1 or Pin2
2	White	Not used	-
3	-	Not used	-
4	Black	TEMP	Pin2 or Pin1

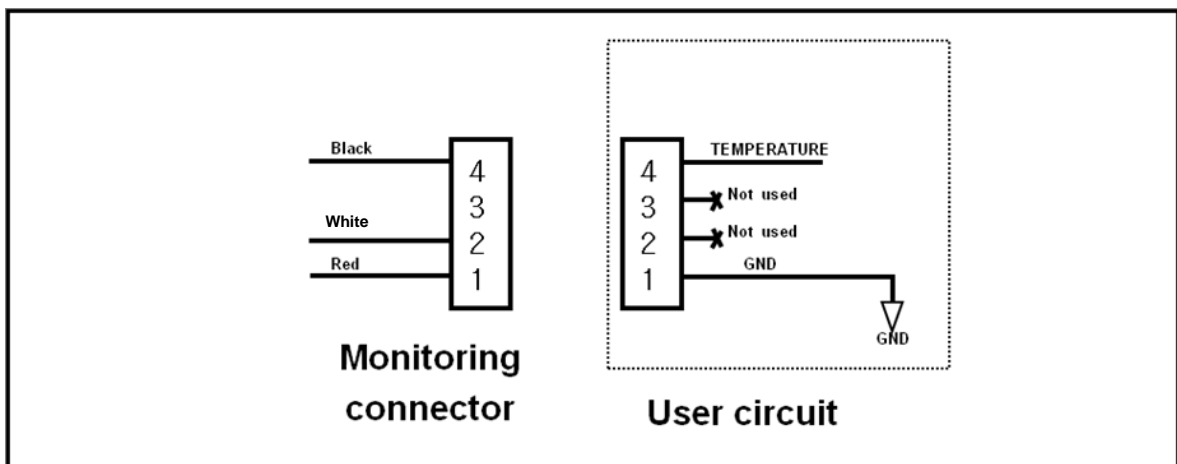

<Fig. 4> Typical output signal receiver circuit to the monitoring connector

- Pin 1, 4 is connected with a NTC thermistor for temperature monitoring. According to temperature variation in the module, the resistance of the thermistor is determined. The resistance measured through the thermistor relates to temperature according to the DK Sensor 10K@ 25°C resistance to temperature chart for the appendix I.
- Pin 2, 3 are not used.

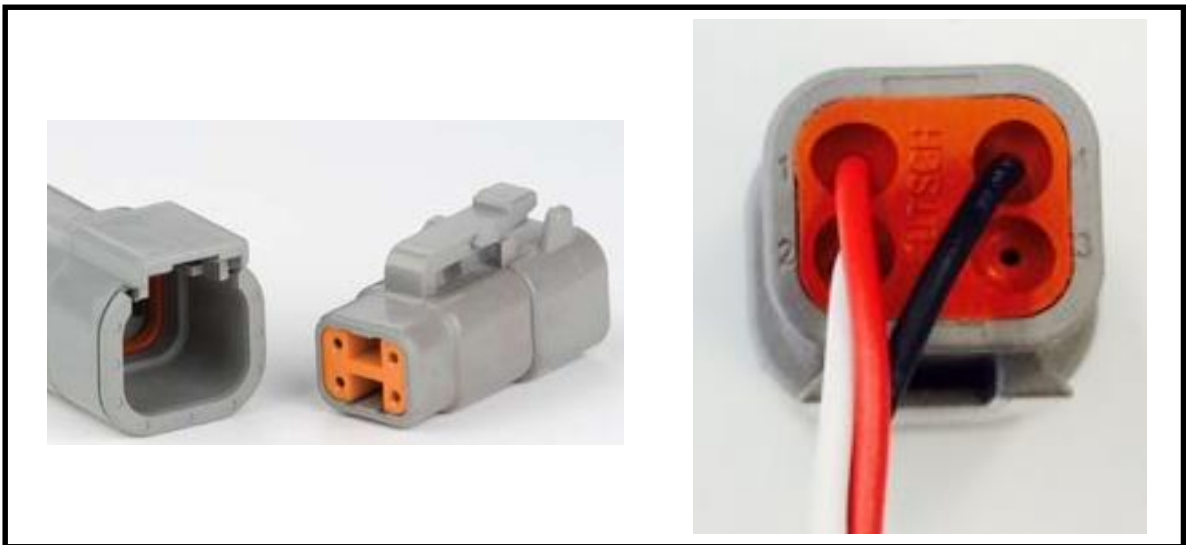

<Fig. 5> Monitoring connector



## 8. Mounting

The modules should not be mounted in locations where they are directly exposed to the environment.

- <Fig. 6> shows the mounting positions of the module.

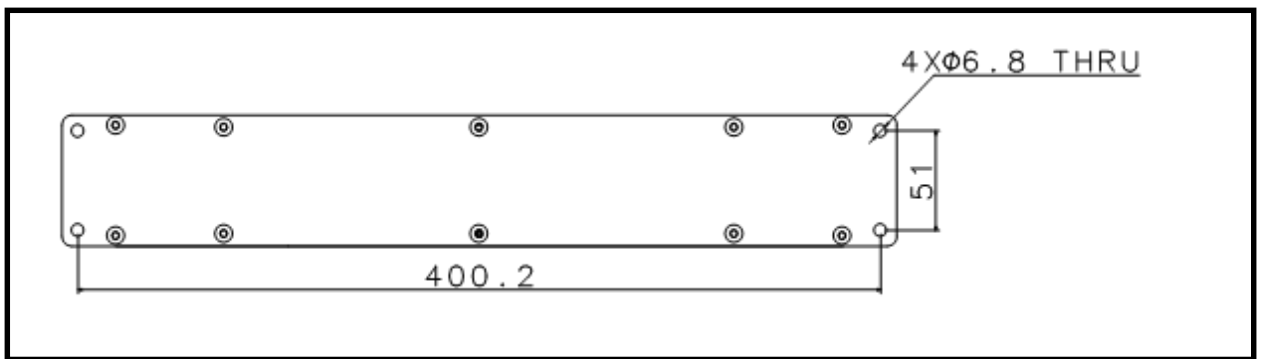

<Fig. 6> Mounting Positions

## 9. Maintenance

### Power Rating

If the applied voltage is over rated voltage, charging the module should be stopped. And the allowable low voltage level of the module depends on the user's requirements, but full discharging to 0V does not affect the module performance.

### Temperature

The module has its optimal operating temperature range of -40 to 65. Over 70°C, charging and discharging should be stopped to preserve its performance and life cycle.

### Do not expose to direct sunlight

For installation do not make the module expose to direct sunlight due to temperature increase inside the module.

### Maintenance

The module has its projected life over 10years at rated voltage and +25°C. However the life cycle of the module may be decreased in high temperature condition or over voltage charging.

If following abnormal module performances are detected, operation should be stopped and checking the electrical & mechanical connections is recommended.

- Detection of high temperature in normal operating conditions
- Internal resistance increase or initial voltage drop increase
- Deformation of the module case

## Appendix I

T(°C)	Rmin(kΩ)	Rcent(kΩ)	Rmax(kΩ)	DR(%)	DT(°C)
-40	332.8	348.4	364.6	4.65%	0.67
-39	311.2	325.5	340.4	4.58%	0.66
-38	291.2	304.3	318.0	4.51%	0.66
-37	272.5	284.7	297.3	4.44%	0.65
-36	255.2	266.4	278.0	4.37%	0.65
-35	239.1	249.4	260.2	4.30%	0.64
-34	224.2	233.7	243.6	4.23%	0.64
-33	210.2	219.0	228.1	4.17%	0.63
-32	197.3	205.4	213.8	4.10%	0.63
-31	185.2	192.7	200.4	4.03%	0.62
-30	173.9	180.8	188.0	3.97%	0.61
-29	163.4	169.8	176.4	3.90%	0.61
-28	153.6	159.5	165.6	3.84%	0.60
-27	144.5	149.9	155.6	3.77%	0.60
-26	135.9	141.0	146.2	3.71%	0.59
-25	127.9	132.6	137.5	3.64%	0.59
-24	120.5	124.8	129.3	3.58%	0.58
-23	113.5	117.5	121.6	3.52%	0.58
-22	107.0	110.7	114.5	3.46%	0.57
-21	100.9	104.3	107.8	3.40%	0.56
-20	95.15	98.33	101.6	3.34%	0.56
-19	89.79	92.74	95.77	3.27%	0.55
-18	84.76	87.50	90.31	3.21%	0.55
-17	80.05	82.59	85.19	3.16%	0.54
-16	75.63	77.98	80.40	3.10%	0.53
-15	71.49	73.66	75.90	3.04%	0.53
-14	67.59	69.61	71.69	2.98%	0.52
-13	63.94	65.81	67.73	2.92%	0.51
-12	60.50	62.24	64.02	2.86%	0.51
-11	57.27	58.88	60.53	2.81%	0.50
-10	54.23	55.73	57.26	2.75%	0.49
-9	51.37	52.76	54.18	2.69%	0.49
-8	48.68	49.97	51.29	2.64%	0.48
-7	46.15	47.35	48.57	2.58%	0.47
-6	43.77	44.88	46.01	2.53%	0.47
-5	41.52	42.55	43.60	2.47%	0.46
-4	39.40	40.36	41.34	2.42%	0.45
-3	37.41	38.29	39.20	2.37%	0.45
-2	35.52	36.35	37.19	2.31%	0.44

Appendix I

T(℃)	Rmin(kΩ)	Rcent(kΩ)	Rmax(kΩ)	DR(%)	DT(℃)
-1	33.74	34.51	35.29	2.26%	0.43
0	32.07	32.78	33.50	2.21%	0.43
1	30.48	31.14	31.81	2.15%	0.42
2	28.99	29.60	30.22	2.10%	0.41
3	27.57	28.14	28.72	2.05%	0.40
4	26.24	26.76	27.30	2.00%	0.40
5	24.97	25.46	25.96	1.95%	0.39
6	23.78	24.23	24.69	1.90%	0.38
7	22.64	23.07	23.49	1.85%	0.37
8	21.57	21.96	22.36	1.80%	0.37
9	20.56	20.92	21.29	1.75%	0.36
10	19.60	19.94	20.27	1.70%	0.35
11	18.69	19.00	19.31	1.65%	0.34
12	17.83	18.12	18.41	1.60%	0.34
13	17.01	17.28	17.54	1.55%	0.33
14	16.24	16.48	16.73	1.51%	0.32
15	15.50	15.73	15.96	1.46%	0.31
16	14.80	15.01	15.22	1.41%	0.30
17	14.14	14.33	14.53	1.36%	0.30
18	13.51	13.69	13.87	1.32%	0.29
19	12.91	13.08	13.24	1.27%	0.28
20	12.35	12.50	12.65	1.23%	0.27
21	11.81	11.95	12.09	1.18%	0.26
22	11.29	11.42	11.55	1.13%	0.25
23	10.81	10.92	11.04	1.09%	0.24
24	10.34	10.45	10.56	1.04%	0.24
25	9.900	10.00	10.10	1.00%	0.23
26	9.472	9.572	9.671	1.04%	0.24
27	9.064	9.164	9.264	1.09%	0.25
28	8.677	8.776	8.875	1.13%	0.26
29	8.308	8.406	8.505	1.18%	0.27
30	7.957	8.054	8.153	1.22%	0.29
31	7.622	7.719	7.817	1.26%	0.30
32	7.304	7.400	7.496	1.30%	0.31
33	7.000	7.095	7.191	1.35%	0.32
34	6.711	6.805	6.900	1.39%	0.33
35	6.436	6.528	6.622	1.43%	0.35
36	6.173	6.265	6.357	1.47%	0.36
37	5.922	6.013	6.104	1.52%	0.37
38	5.683	5.772	5.862	1.56%	0.38
39	5.455	5.543	5.631	1.60%	0.40
40	5.237	5.324	5.411	1.64%	0.41
41	5.030	5.114	5.200	1.68%	0.42
42	4.831	4.915	4.999	1.72%	0.44
43	4.641	4.724	4.807	1.76%	0.45
44	4.460	4.541	4.623	1.80%	0.46

## Appendix I

T(°C)	Rmin(kΩ)	Rcent(kΩ)	Rmax(kΩ)	DR(%)	DT(°C)
45	4.287	4.367	4.447	1.84%	0.47
46	4.122	4.200	4.279	1.88%	0.49
47	3.964	4.040	4.118	1.92%	0.50
48	3.812	3.887	3.964	1.96%	0.51
49	3.668	3.741	3.816	2.00%	0.53
50	3.529	3.601	3.675	2.04%	0.54
51	3.397	3.468	3.540	2.08%	0.55
52	3.270	3.339	3.410	2.11%	0.57
53	3.149	3.217	3.286	2.15%	0.58
54	3.032	3.099	3.167	2.19%	0.59
55	2.921	2.986	3.053	2.23%	0.61
56	2.814	2.878	2.944	2.27%	0.62
57	2.712	2.775	2.839	2.30%	0.64
58	2.614	2.675	2.738	2.34%	0.65
59	2.520	2.580	2.642	2.38%	0.66
60	2.430	2.489	2.549	2.41%	0.68
61	2.344	2.401	2.460	2.45%	0.69
62	2.261	2.317	2.375	2.49%	0.71
63	2.181	2.237	2.293	2.52%	0.72
64	2.105	2.159	2.214	2.56%	0.74
65	2.032	2.085	2.139	2.60%	0.75
66	1.962	2.013	2.066	2.63%	0.77
67	1.894	1.945	1.997	2.67%	0.78
68	1.829	1.879	1.930	2.70%	0.80
69	1.767	1.815	1.865	2.74%	0.81
70	1.707	1.755	1.803	2.77%	0.83
71	1.650	1.696	1.744	2.81%	0.84
72	1.594	1.640	1.686	2.84%	0.86
73	1.541	1.586	1.631	2.88%	0.87
74	1.490	1.534	1.578	2.91%	0.89
75	1.441	1.483	1.527	2.95%	0.90
76	1.394	1.435	1.478	2.98%	0.92
77	1.348	1.389	1.431	3.01%	0.93
78	1.304	1.344	1.385	3.05%	0.95
79	1.262	1.301	1.341	3.08%	0.96
80	1.222	1.260	1.299	3.11%	0.98
81	1.183	1.220	1.258	3.15%	1.00
82	1.145	1.181	1.219	3.18%	1.01
83	1.109	1.144	1.181	3.21%	1.03
84	1.074	1.109	1.145	3.25%	1.04
85	1.040	1.074	1.110	3.28%	1.06
86	1.008	1.041	1.076	3.31%	1.08
87	0.9765	1.009	1.043	3.34%	1.09
88	0.9464	0.9785	1.011	3.38%	1.11
89	0.9174	0.9488	0.9811	3.41%	1.12
90	0.8894	0.9201	0.9517	3.44%	1.14

Appendix II

Drawing

