



Document Number	V2_20150317
-----------------	-------------

# Product specification

LSUC 002R8S 0350F EA

LSUC 002R8S 0400F EA

LSUC 002R8S 0450F EA



# Product specification

## Physical properties

Dimension in mm (not to scale)

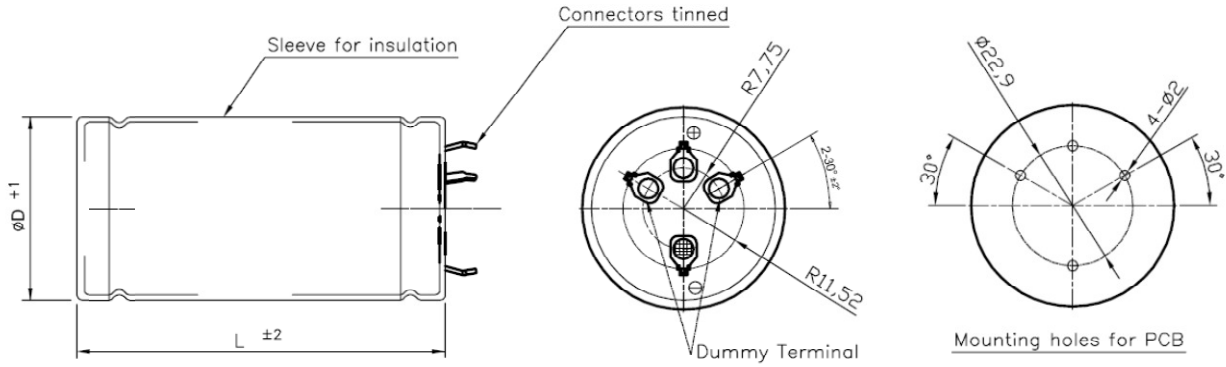

## Specification

Rated Voltage	2.8 V	
Surge Voltage	3.0 V	
Capacitance Tolerance	0% / 20%	
Resistance Tolerance	< Spec. Value	
Operating temperature range	-40 ~ 65 °C	
Storage temperature range	-40 ~ 70 °C	
Life Time (25°C / 65°C)	After 10 years at rated voltage and +25 °C 1,500 Hours at rated voltage and +65 °C	
	Capacitance change	Within 30% of initially specified value
	Internal resistance change	Within 100% of initially specified value
Cycle Life (25°C)	After 500,000 cycles between rated voltage to half rated voltage at +25 °C	
	Capacitance change	Within 30% of initially specified value
	Internal resistance change	Within 100% of initially specified value
Certifications	ROHS, REACH, UL810A (Certificate No. : MH46367)	

## Standard Ratings

Part number	Capacitance (F)	Resistance (mΩ)		Max. Current (A)	Continuous Current (A)	Leakage Current (mA)	Max. Stored Energy (Wh)
		(1KHz)	DC				
LSUC 002R8S 0350F EA	350	3.0	3.2	231	25	< 1	0.38
LSUC 002R8S 0400F EA	400	2.8	3	255	25	< 1	0.44
LSUC 002R8S 0450F EA	450	2.8	3	268	25	< 1	0.49

Part number	Dimension (mm)		Weight (g, +3)
	D1 (+ 1.0)	L (±2.0)	
LSUC 002R8S 0350F EA	35.0	61.0	72
LSUC 002R8S 0400F EA	35.0	66.0	80
LSUC 002R8S 0450F EA	35.0	71.0	88

## Technical Information (1)

### How to calculate specification value

#### 1. The Measurement Methods

##### 1-1 Capacitance

Apply rated voltage and charge for 5min after the constant current / constant voltage power supply has achieved the rated voltage. After a charge for 10min has finished, discharge with 10mA/F to 0.1V.

Measure the time  $t_1$  to  $t_2$  where the voltage between capacitor terminals at the time of discharge reduces from  $V_1$  to  $V_2$  as shown figure and calculate the capacitance value by the following formula:

- 1) Constant current charge with 10mA/F to  $V_R$
- 2) Constant voltage charge at  $V_R$  for 5min
- 3) Constant current discharge with 10mA/F to 0.1V

$$C = \frac{I \times (t_2 - t_1)}{V_2 - V_1} \quad (V_2 = 2.24V, V_1 = 1.12V)$$

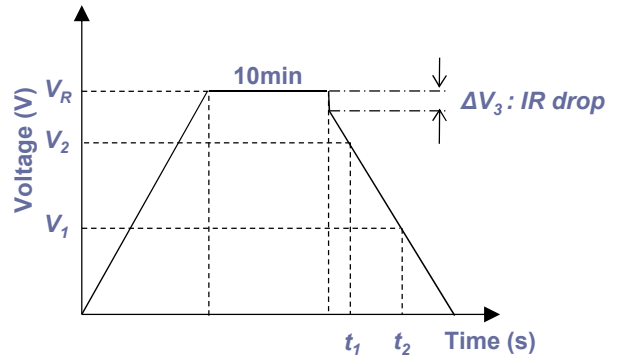

##### 1-2 Resistance

The AC and DC resistance of a capacitor shall be calculated by the following formula;

$$R_{AC} = \frac{V}{I_{AC}} \quad (\text{The frequency of the measuring voltage shall be 100Hz})$$

$$R_{DC} = \frac{\Delta V}{I_{DC}}$$

- Where
- $R_{AC}$  is the AC internal resistance ( $\Omega$ );
  - $R_{DC}$  is the DC internal resistance ( $\Omega$ );
  - $V$  is the effective value of AC voltage (V);
  - $\Delta V$  is the drop voltage for 10ms (V);
  - $I_{AC}$  is the effective value of AC current (A);
  - $I_{DC}$  is the discharge current (A); 5A

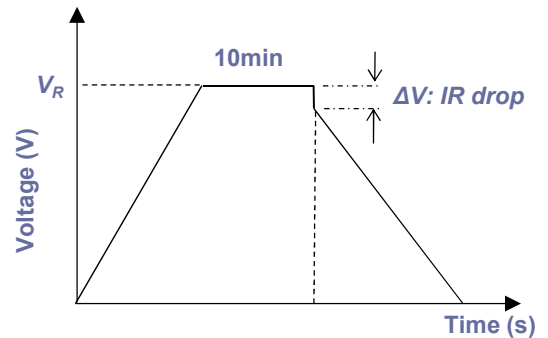

## Technical Information (2)

### 1-3 Leakage current & Self discharge

The leakage current shall be measured using the direct voltage appropriate to the test temperature(25℃) for 72hrs. Self discharge voltage shall be measured after charging up for 12hrs, disconnect the capacitor terminals from the voltage source. The capacitor shall be kept under standard condition for 100hrs.

### 1-4 Maximum current

Current for 1sec discharge from the rated voltage to the half of it in constant current discharge,

$$I_{Max} = \frac{V_R - 0.5 \cdot V_R}{\Delta t / C + R_{DC}}$$

Where  $I_{Max}$  is the Maximum current (A);

$\Delta t$  is the discharge time (sec), 1 sec in this case ;

$C$  is the capacitance (F);

$R_{DC}$  is the DC resistance ( $\Omega$ );

$V_R$  is the rated voltage (V).

### 1-5 Maximum stored energy ( $E_{MAX}$ )

$$E_{MAX} (Wh) = \frac{\frac{1}{2} C V_R^2}{3600}$$

## 2. The Standard Atmospheric Condition for Measurement

All test and measurements shall be made under standard atmospheric conditions for testing. Before the measurements are made, the capacitor shall be stored at the measuring temperature for a time sufficient to allow the entire capacitor to reach this temperature. The period as prescribed for recovery at the end of a test is a normally sufficient for this purpose.

Temperature : 15~35 ℃

Relative humidity : 25~75%

Air Pressure : 86~106 kPa