

CUSTOMER: INELTRO SWITZERLAND
CUSTOMER PN:
GPN: E91F401VNT182MC80U
CONTROL NO.: G180260W0056 (99610)

ELECTRICAL CRITERIA

CAPACITANCE (120Hz/20°C): 1800 μ F
 CAP.TOLERANCE: ± 20 %
 RATED Vdc 400 V
 SURGE Vdc (30 sec): 450 V
 MAX. ESR (120Hz/20°C) : 62 m Ω
 MAX. Irms (120Hz/105°C): 5.90 A
 MAX. DCL (Vdc/5:00/20°C): 3.000 mA

MECHANICAL CRITERIA

MAX. VIBRATION: 10-55Hz 10g
 TYP. WEIGHT: 207 grams

OPERATING CRITERIA

MAX. TEMPERATURE: +105 °C
 MIN. TEMPERATURE: -25 °C
 LOAD LIFE (Vdc+Irms/105°C): 5000 Hrs
 MAX. Δ CAP. (measured value): ± 20 %
 MAX. ESR (specified value): +200 %
 MAX. DCL (Vdc/5:00/20°C): 3.000 mA
 SHELF LIFE (105°C): 1000 Hrs
 MAX. Δ CAP. (measured value): ± 20 %
 MAX. ESR (specified value): +150 %
 MAX. DCL (Vdc/5:00/20°C): 3.000 mA

IRMS FREQUENCY MULTIPLIERS

50Hz	120Hz	300Hz	1kHz	10kHz	100kHz
0.77	1.00	1.16	1.30	1.41	1.43

IRMS AMBIENT MULTIPLIERS

45°C	60°C	70°C	85°C	105°C
2.64	2.23	2.12	1.73	1.00

COMMENTS

RoHS Compliant

DIMENSIONAL CRITERIA

X	mm		in	
	min	max	min	max
\varnothing D	50.0	- 0.0		+ 1.0
L	80.0	- 2.0		+ 2.0
P	5.8	- 1.0		+ 1.0
W	1.5	- 0.2		+ 0.2
W ₁	0.8	- 0.1		+ 0.1
W ₂	0.8	- 0.1		+ 0.1

MARKING

U91F 105°C
 400V 1800uF(M)
 Date Code

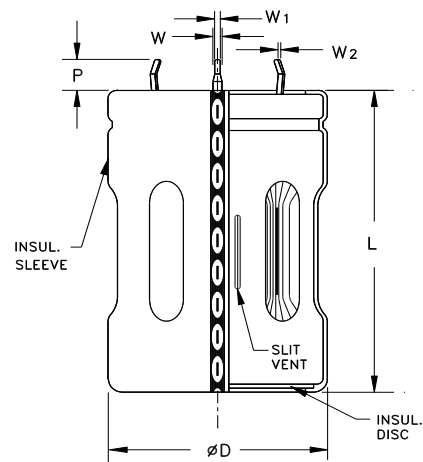
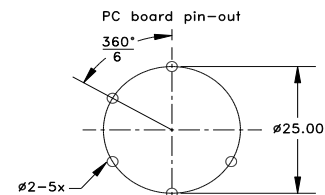
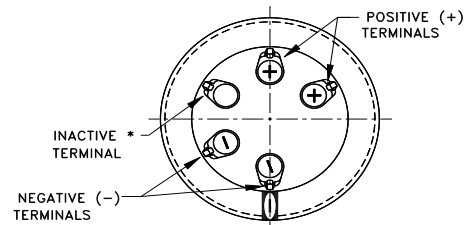

* Inactive terminal for mechanical support only.

TDS NO.: TDS-19-0030
AUTHOR: TMASH
DATE: 28-FEB-2019