

## High Accuracy Three Axis Accelerometer

### ■ GENERAL DESCRIPTION

The M-A352 is a three axis digital output accelerometer featuring ultra-low noise, high stability, and low power consumption using fine processing technology of Quarts. Incorporating both high accuracy and durability, the versatile M-A352 is well suited to a wide-range of challenging applications such as SHM, seismic observation, condition monitoring for industrial equipment, and pose detection for industrial machinery (i.e. construction machinery/attachments, agricultural machinery/ implements, robots).

### ■ FEATURES

- **Ultra-low noise: 0.2 $\mu$ G/ $\sqrt{\text{Hz}}$  typ.**
- **Improved shock resistance: 1,000G**
- **Selectable output format: Acceleration / Tilt Angle**
- **Selectable interface: SPI / UART**
- **Programmable low-pass digital filters**
- **Low jitter external trigger function for synchronous sampling**
- **Solid Metallic Case (Size : 48mm x 24mm x 16mm, Weight: 25g)**



### ■ SPECIFICATION

T<sub>A</sub>=-30°C to +85°C, VCC=3.15V~3.45V,  $\leq \pm 1\text{G}$ , unless otherwise noted.

Parameter	Test Conditions / Comments	Min	Typ	Max	Unit
<b>SPECIFICATIONS</b>					
Output Dynamic Range	f = DC ~ 460Hz			$\pm 15$	G
Scale Factor	2 <sup>-24</sup> G/LSB		0.06		$\mu\text{G}/\text{LSB}$
Sensitivity Error	25°C, $\leq 1\text{G}$		$\pm 500$		$\times 10^{-6}$ (ppm)
Nonlinearity	$\leq 1\text{G}$ , Best fit straight line, RT			$\pm 0.03$	% of FS
Misalignment	25°C			$\pm 0.1$	Deg
Initial Error	25°C			$\pm 2$	mG
Bias Repeatability	T <sub>A</sub> =25°C and VCC=3.3V for one year after shipment		3		mG
Bias Temperature Error	25°C			$\pm 2$	mG
Noise Density	25°C, Avg, f = 0.5Hz ~ 6Hz		0.2	0.7	$\mu\text{G}/\sqrt{\text{Hz}}$ , rms
Cantilever Resonance frequency	25°C, VCC3.3V		850		Hz
VRC	at 50Hz, 25°C, VCC3.3V			$\pm 50$	$\mu\text{G}/\text{G}^2$
Power Supply Current	Standard noise floor condition, 200Sps, Average		13.2	18.0	mA
	Reduced noise floor condition, 200Sps, Average		16.2	20.0	mA
	Sleep mode		1.3	2.0	mA
<b>FUNCTION</b>					
Built-in LPF Cut off	-6dB at 25°C, selectable	9		460	Hz
User LPF			4, 64, 128, 512		Tap
Output Data Rate		50		1,000	Sps
Ext.Trigger Input Cycle		1		20	ms
Ext.Trigger Jitter	ADC's completion to Ext.Trigger input	0		5	$\mu\text{s}$
<b>RECOMMENDED OPERATING CONDITION</b>					
VCC to GND		3.15	3.3	3.45	V
Operating temperature range	No condensation	-30		85	°C
<b>ABSOLUTE MAXIMUM RATINGS</b>					
Acceleration/Shock	Half-sine 0.2msec		1,000		G
MTBF	JIS-C5003, 60% reliability leve		87,600		Hour
Storage Temperature Range	No condensation	-40		85	°C

Note) This accelerometer is referenced to the standard gravity acceleration value. (9.80665m/s<sup>2</sup>)

# M-A352AD10

## OUTLINE DIMENSIONS

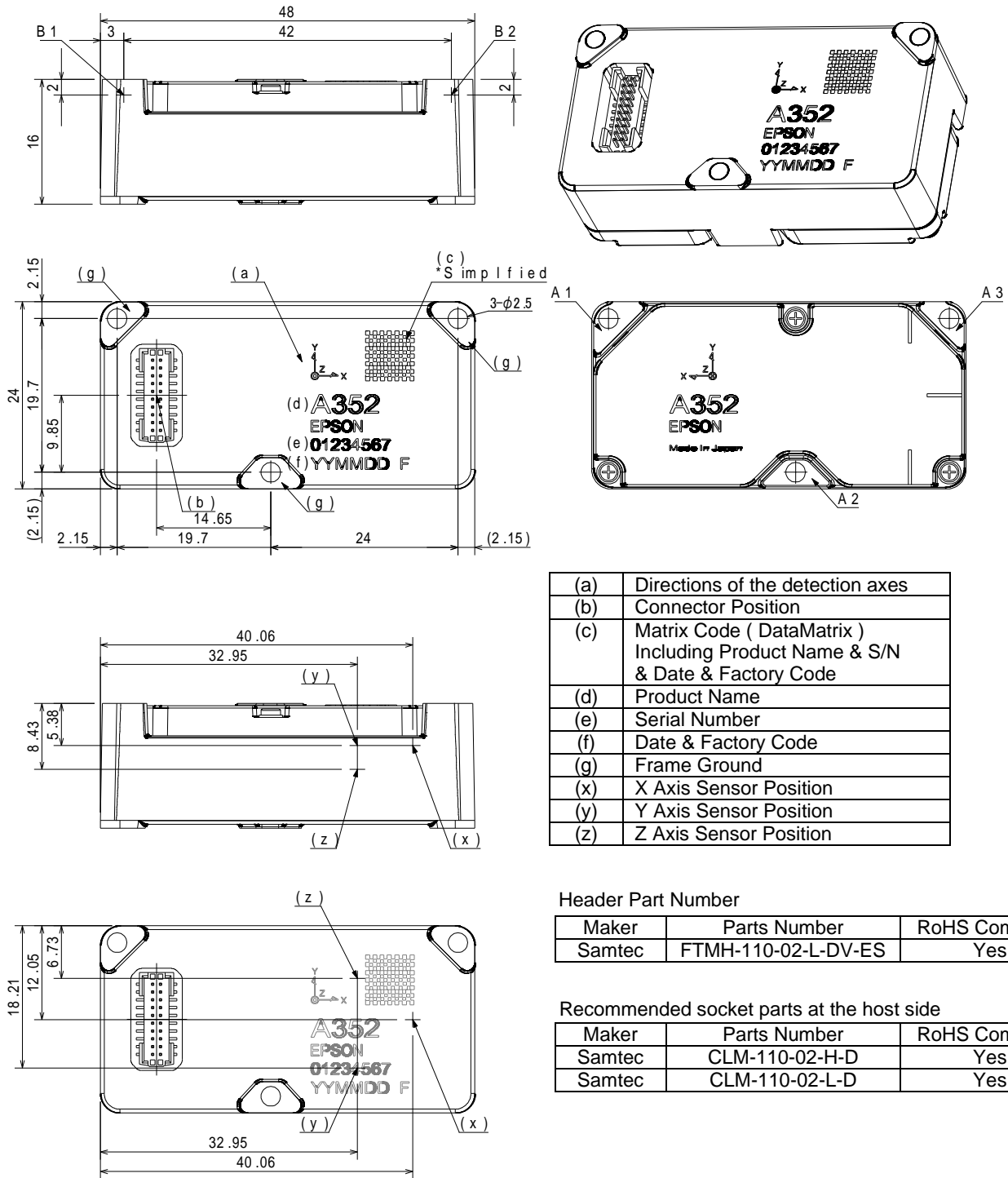

(a)	Directions of the detection axes
(b)	Connector Position
(c)	Matrix Code ( DataMatrix ) Including Product Name & S/N & Date & Factory Code
(d)	Product Name
(e)	Serial Number
(f)	Date & Factory Code
(g)	Frame Ground
(x)	X Axis Sensor Position
(y)	Y Axis Sensor Position
(z)	Z Axis Sensor Position

### Header Part Number

Maker	Parts Number	RoHS Compliant
Samtec	FTMH-110-02-L-DV-ES	Yes

### Recommended socket parts at the host side

Maker	Parts Number	RoHS Compliant
Samtec	CLM-110-02-H-D	Yes
Samtec	CLM-110-02-L-D	Yes

\*1) This product is calibrated based on the surfaces A1, A2, A3, and B1, B2.

\*2) In order to demonstrate the performance of the product properly, please fix surfaces A1, A2, A3 to rugged parts with M2 screw.

\*3) When high connection reliability is required, please tighten this product together with the board on which the connector is mounted.

## ■ PIN LAYOUT AND FUNCTION

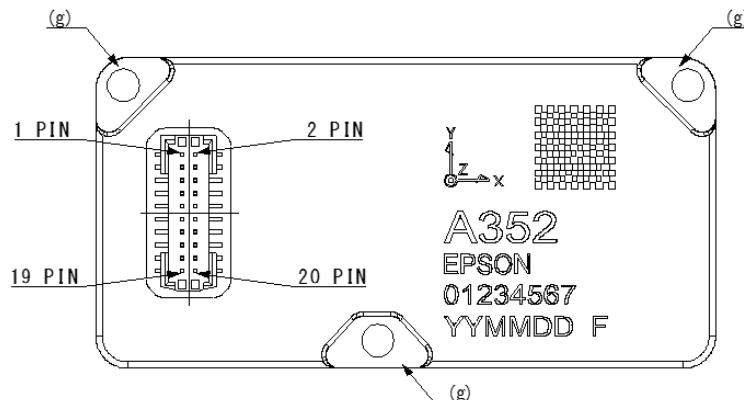

Pin No.	Mnemonic	Type*1	Description
1	SCLK	I	SPI Serial Clock *2
2	SDO	O	SPI Data Output *2
5	SDI	I	SPI Data Input *2
6	/CS	I	SPI Chip Select *2
7	SOUT	O	UART Data Output *2
9	SIN	I	UART Data Input *2
13	DRDY	O	Data Ready
14	EXT	I	External Trigger Input (Sleep Wakeup Input)
16	/RST	I	Reset
10,11,12	VCC	S	Power Supply 3.3V
3,4,8,15	GND	S	Ground *3
17,18,19,20	NC	N/A	Do Not Connect

\*1 Pin Type I: Input, O: Output, I/O: Input/Output, S: Supply, N/A: Not Applicable

\*2 Connect only one of the serial interfaces (SPI or UART) at a time. This product malfunctions when both SPI and UART are connected at the same time.

\*3 Please connect (g) Frame Ground to any GND pin (No.3, 4, 8, 15).

## ■ EVALUATION TOOLS

Evaluation tools can be provided for the M-A352. For details, contact our representatives.

Product Model Number	Product Name	Comments
E92E609041	M-G32EV041	USB Evaluation Board for M-A352AD10 *Works with Logger Software.
E92E609051	M-G32EV051	Relay board for M-A352AD10 *Combination with M-G32EV041 is possible.

## ■ Noise Density Data

Power Spectrum Density (Reduced noise floor condition)

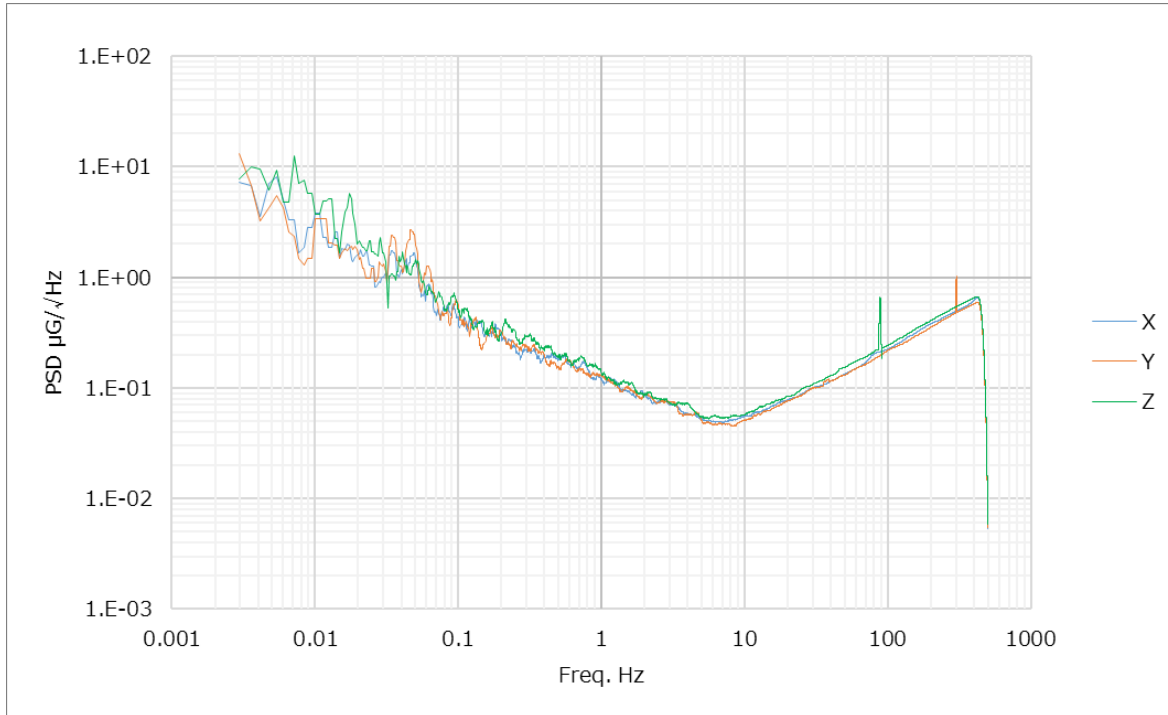

### NOTICE:

No part of this material may be reproduced or duplicated in any form or by any means without the written permission of Seiko Epson. Seiko Epson reserves the right to make changes to this material without notice. Seiko Epson does not assume any liability of any kind arising out of any inaccuracies contained in this material or due to its application or use in any product or circuit and, further, there is no representation that this material is applicable to products requiring high level reliability, such as, medical products. Moreover, no license to any intellectual property rights is granted by implication or otherwise, and there is no representation or warranty that anything made in accordance with this material will be free from any patent or copyright infringement of a third party. This material or portions thereof may contain technology or the subject relating to strategic products under the control of the Foreign Exchange and Foreign Trade Law of Japan and may require an export license from the Ministry of Economy, Trade and Industry or other approval from another government agency.

All brands or product names mentioned herein are trademarks and/or registered trademarks of their respective companies.

©Seiko Epson Corporation 2019, All rights reserved

## SEIKO EPSON CORPORATION

DEVICE SALES & MARKETING DEPT.

29th Floor, JR Shinjuku Miraina Tower, 4-1-6 Shinjuku, Shinjuku-ku, Tokyo,  
160-8801, Japan  
Phone: +81-3-6682-4322 FAX: +81-3-6682-5016

Modified; Nov. 2019  
Rev.191112