

swissbit®

Product Data Sheet

Industrial M.2 PCIe SSD

N-10m2 2280 Series PCIe 3.1, 3D TLC

Commercial and Industrial
Temperature Grade

Date: January 27, 2021
Revision: 1.02

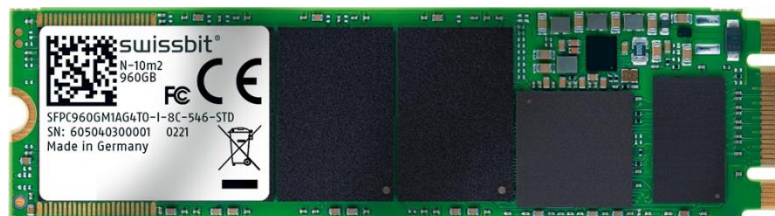

Contents

1. PRODUCT SUMMARY	3
2. PRODUCT FEATURES	4
3. ORDERING INFORMATION	5
4. PRODUCT DESCRIPTION	6
4.1 PERFORMANCE SPECIFICATIONS	7
4.2 CURRENT CONSUMPTION	7
4.3 ENVIRONMENTAL SPECIFICATIONS	8
4.4 REGULATORY COMPLIANCE	9
4.5 MECHANICAL SPECIFICATIONS	9
4.6 RELIABILITY AND ENDURANCE	10
4.7 DRIVE GEOMETRY SPECIFICATION	10
5. ELECTRICAL INTERFACE	11
6. PACKAGE MECHANICAL	13
7. NVME COMMANDS	14
8. IDENTIFY DEVICE INFORMATION	14
9. HEALTH MONITORING FUNCTIONALITY	16
9.1 LOG PAGES SUBCOMMANDS	18
10. PART NUMBER DECODER	19
11. MARKING SPECIFICATION	21
11.1 TOP VIEW	21
11.2 PRINT ON THE LABEL	21
12. REVISION HISTORY	22

N-10m2 2280 Series – Industrial M.2 PCIe SSD

120 GBytes up to 960 GBytes

1. Product Summary

- **Capacities:** 120 GBytes, 240 GBytes, 480 GBytes, 960 GBytes
- **Form Factor:** PCI Express® M.2 2280 (80 mm x 22 mm x 2.23 mm)
- **Compliance:** PCI Express (PCIe) Specification Revision 3.1
- **Interface:** Gen3 x 2 Lanes
 - Drive operates in x1 mode in x1 M.2 PCIe slots
 - Drive operates in x2 mode in x2 or x4 M.2 PCIe slots
- **Command Sets:** Supports NVMe 1.2
- **Performance:**
 - Read Performance: Sequential Read up to 1,600 MBytes/s, Random Read 4K up to 190,000 IOPS
 - Write Performance: Sequential Write up to 1,000 MBytes/s, Random Write 4K up to 190,000 IOPS
- **Operating Temperature Range²:**
 - Commercial: 0 °C to 70 °C
 - Industrial: -40 °C to 85 °C
- **Storage Temperature Range:** -40 °C to 85 °C
- **Operating Voltage:** 3.3 V ± 5%
- **Low Power Consumption**
- **Data Retention:** 10 Years @ Life Begin; 1 Year @ Life End
- **Endurance in TeraBytes Written (TBW) @ Max Capacity³:**
 - Client ≥ 2280
 - Enterprise ≥ 290
- **Shock/Vibration:** 1,500 *g* / 50 *g*
- **High-Performance 32-Bit Processor with Integrated, Parallel Flash Interface Engines:**
 - Triple-Level Cell (TLC) 3D NAND Flash
 - ECC with up to 120 bit correction per 1 KByte page
- **High Reliability:**
 - Mean Time Between Failure (MTBF): > 2,000,000 hours
 - Data Reliability: < 1 non-recoverable error per 10¹⁶ bits read

¹ The verification of the host system and storage device compatibility is the customer's responsibility. Swissbit can provide guidance and support upon request.

² Adequate airflow is required to ensure the temperature, as reported in the S.M.A.R.T. data, does not exceed 125°C (industrial temperature drive) and 110°C (commercial temperature drive) respectively.

³ According to JEDEC (JESD471), the time to write the full TBW is a minimum of 18 months. Higher average daily data volume reduces the specified TBW. The values listed are estimates and are subject to change without notice.

2. Product Features

- Dynamic and Static Wear Leveling
- Subpage Mode Flash Translation Layer (FTL)
- Data Care Management
 - Active: Adaptive Read Refresh
 - Passive: Background Media Scan
- Lifetime Enhancements
 - Dynamic Bad Block Remapping
 - Write Amplification Reduction
- On-Board Power Fail Protection
- Deallocate and I/O Queues
- NVMe Security Command Support
- Active State Power Management (ASPM) Support
- In-Field Firmware Update⁴
- Enterprise-Grade Self-Monitoring, Analysis, and Reporting Technology (S.M.A.R.T.)
- 30 µinch Gold-Plated Connector (IPC-6012B Class 2 Compliant)
- End-to-End (E2E) Data Protection
- AES256 Encryption
- TCG Opal 2.0 Compliant (on request)
- SMBus support
- Life Cycle Management
- Controlled "Locked" BOM
- RoHS-6 Compliant
- Swissbit Life Time Monitoring (SBLTM) Tool and SDK for SBLTM (on request)



⁴ A host system that supports in-field firmware updates is recommended.

3. Ordering Information

Table 1: Standard Product List

Capacity	Part Number
120 GBytes	SFPC120GMxAG2T0-t-6B-5y6-STD
240 GBytes	SFPC240GMxAG4T0-t-6B-5y6-STD
480 GBytes	SFPC480GMxAG2T0-t-8C-5y6-STD
960 GBytes	SFPC960GMxAG4T0-t-8C-5y6-STD

x = product generation; t = temperature grade; y = firmware revision

Table 2: Available Part Numbers

Capacity	Part Number – Commercial Temperature	Part Number – Industrial Temperature
120 GBytes	SFPC120GM1AG2T0-C-6B-546-STD	SFPC120GM1AG2T0-I-6B-546-STD
240 GBytes	SFPC240GM1AG4T0-C-6B-546-STD	SFPC240GM1AG4T0-I-6B-546-STD
480 GBytes	SFPC480GM1AG2T0-C-8C-546-STD	SFPC480GM1AG2T0-I-8C-546-STD
960 GBytes	SFPC960GM1AG4T0-C-8C-546-STD	SFPC960GM1AG4T0-I-8C-546-STD

4. Product Description

The Swissbit® N-10m2 2280 Solid State Drive (SSD) leverages the M.2 standard and NVMe standard to support a PCIe electrical interface as well as AES encryption, E2E data protection and TCG Opal standards. The NVMe controller and the newest 3D NAND flash technology provides robust, non-volatile storage solution for today's embedded computing applications. A functional block diagram of the N-10m2 2280 SSD is provided below in Figure 1.

Figure 1: N-10m2 2280 Functional Block Diagram

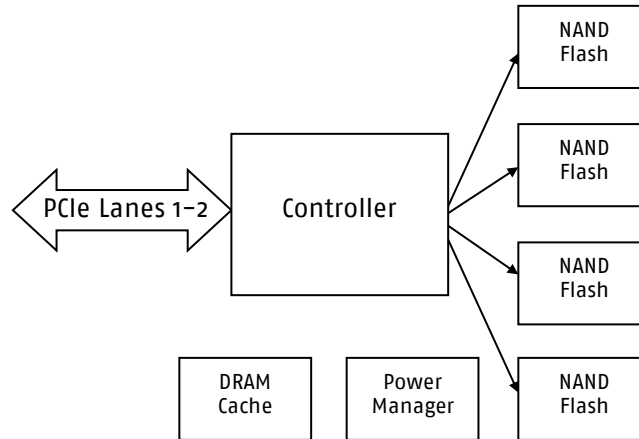

The N-10m2 2280 SSD incorporates a 75-position edge connector with B and M keys to support host read/write, control, and power activity per the applicable JEDEC specification.

The on-board NVMe controller manages the interface between the host and the non-volatile NAND flash memory array. The controller is designed to support PCIe interface speeds and utilizes a dual CPU architecture, providing an optimum balance between read/write performance, Data Care Management, and power fail protection.

Swissbit's N-10m2 2280 SSDs deliver an impressive IOPS rate and highest endurance by combining Bit Cost Scalable (BiCS) 3D flash technology with a high-end controller architecture, firmware, and an optimized configuration. The SSDs are designed for applications requiring high data transfer rates (see Table 3: Read/Write Performance). This performance is achieved through an on-board DRAM cache, 4-channel flash controller, and 2-lane PCIe interface.

An on-controller Error Correction Code (ECC) engine provides the N-10m2 2280 hardware ECC, which is capable of correcting up to 120 bits per 1 KByte page. This engine, combined with Swissbit's Data Care Management firmware, provides both passive and active data management strategies to ensure data integrity and extract the maximum possible endurance and reliability from the NAND flash array. These strategies include, but are not limited to, Global Wear Leveling, Adaptive Read Refresh, and Dynamic Block Remapping.

Related Documentation

- NVM Express – Revision 1.2, November 3, 2014 (<https://nvmexpress.org/>)
- PCI Express M.2 standard – PCI Express M.2 Specification, Revision 1.1, December 9, 2016 (<https://pcisig.com>)

4.1 Performance Specifications

The N-10m2 2280 read/write sequential and random CDM performance benchmarks are detailed in the following Table 3.

Table 3: Read/Write Performance⁵

Capacity	Sequential Read (MBPS)	Sequential Write (MBPS)	Random Read 4K (IOPS)	Random Write 4K (IOPS)
120 GBytes	1,500	500	92,000	120,000
240 GBytes	1,600	950	180,000	180,000
480 GBytes	1,600	1,000	180,000	180,000
960 GBytes	1,600	1,000	190,000	190,000

4.2 Current Consumption

The drive-level current consumption as a function of operating mode is shown in the following Table 4.

Table 4: Current Consumption⁶

Capacity	Sequential Read	Sequential Write	Random Read 4K	Random Write 4K	Idle P50	Idle P53	Idle P54	Unit
120 GBytes	870	620	680	620	420	135	120	mA
240 GBytes	1,000	800	885	790	415	135	120	
480 GBytes	1,040	880	855	865	420	140	120	
960 GBytes	1,235	1,105	1,100	1,100	430	140	120	

⁵ The values are measured using Crystal Disk Mark 6.0.2. Performance depends on flash type and number, file/cluster size, and burst speed.

⁶ All values are the maximum recorded running IOMeter script for Read/Write operations with 1MB transfer size in 1 minute intervals at 25 °C, with nominal supply voltage and PCIe Gen3 x 2 interface.

4.3 Environmental Specifications

4.3.1 Recommended Operating Conditions

The recommended operating conditions for the N-10m2 2280 SSD are provided in the following Table 5.

Table 5: Recommended Operating Conditions⁷

Parameter	Value
Commercial Operating Temperature	0 °C to 70 °C
Industrial Operating Temperature	-40 °C to 85 °C
Power Supply V _{CC} Voltage	3.3 V ± 5%

4.3.2 Recommended Storage Conditions

The recommended storage conditions are listed in the following Table 6.

Table 6: Recommended Storage Conditions

Parameter	Value
Commercial Storage Temperature	-40 °C to 85 °C
Industrial Storage Temperature	-40 °C to 85 °C

4.3.3 Shock, Vibration and Humidity

The maximum shock, vibration and humidity conditions are listed in the following Table 7.

Table 7: Shock, Vibration and Humidity

Parameter	Value
Non-Operating Shock	1,500 g, 0.5 ms pulse duration, half-sine wave (IEC 60068-2-27 and JESD22-B110 cond. B)
Non-Operating Vibration	50 g, 80-2,000 Hz, 3 axes, 12 cycles (IEC 60068-2-6, MIL-STD-883 H Method 2007.3)
Humidity (Non-Condensing)	85% RH 85 °C, 1000 hrs, max. supply voltage (JESD22-A101B)

⁷ Adequate airflow is required to ensure the temperature, as reported in the S.M.A.R.T. data, does not exceed 125°C (industrial temperature drive) and 110°C (commercial temperature drive) respectively.

4.4 Regulatory Compliance

The N-10m2 2280 devices comply with the directives and standards listed in the following Table 8.

Table 8: Regulatory Compliance

Abbreviation	Regulation/ Standard
EMC	(EU) 2014/30 (FCC) 47 CFR Part 15
RoHS	(EU) 2011/65/EU with 2015/863 and 2017/2102
REACH	(EU) 1907/2006 and 207/2011
WEEE	(EU) 2012/19

4.5 Mechanical Specifications

The N-10m2 2280 SSD consists of a flash controller and NAND flash memory devices. The controller interfaces with a host system, allowing data to be written to and read from the flash memory array. Physical dimensions are detailed in the following Table 9. Figure 3 on page 13 illustrates the N-10m2 2280 dimensions.

Table 9: Physical Dimensions

Physical Dimensions		Unit
Length	80.00±0.15	mm
Width	22.00±0.15	
Thickness (Max)	2.23	
Weight (Max Capacity)	≤ 8.00	g

4.6 Reliability and Endurance

The Mean Time Between Failure (MTBF) is specified to exceed the value listed in the following Table 10. Data reliability with effective error tolerance and data retention at the beginning and end of life is also provided.

Table 10: Reliability

Parameter	Value
MTBF (at 25 °C)	> 2,000,000 hours
Data Reliability	< 1 Non-Recoverable Error per 10 ¹⁶ Bits Read
Data Retention (up to 40°C)	10 Years at Start (JESD47), 1 Year at EOL

Endurance represented as both TeraBytes Written (TBW) and full Drive Writes Per Day (DWPD) for different application scenarios is provided in the following Table 11.

Table 11: Endurance^{8, 9}

Capacity	Client		Enterprise	
	TBW	DWPD ¹⁰	TBW	DWPD ¹⁰
120 GBytes	190	1.43	45	0.33
240 GBytes	405	1.54	75	0.29
480 GBytes	875	1.66	150	0.29
960 GBytes	2,280	2.17	290	0.28

4.7 Drive Geometry Specification

The N-10m2 2280 drive geometry is set to report industry standard LBA settings per the IDEMA standard (LBA1-03). The values for each capacity are shown in the following Table 12.

Table 12: Drive Geometry

Raw Capacity	User Capacity ¹¹	Total LBA	User Addressable Bytes
		Decimal	(Unformatted)
128 GBytes	120 GBytes	234,441,648	120,034,123,776
256 GBytes	240 GBytes	468,862,128	240,057,409,536
512 GBytes	480 GBytes	937,703,088	480,103,981,056
1024 GBytes	960 GBytes	1,875,385,008	960,197,124,096

⁸ Client and Enterprise workloads follow the JEDEC JESD219 standard. Enterprise workload values are measured based on 168 hours of runtime. 1 TByte = 10¹² bytes

⁹ According to JEDEC (JESD471), the time to write the full TBW is a minimum of 18 months. Higher average daily data volume reduces the specified TBW. The values listed are estimates and are subject to change without notice

¹⁰ DWPD values are based on a service life of 3 years

¹¹ 1 GByte = 10⁹ bytes

5. Electrical Interface

This 75-position M.2 connector (Figure 2) incorporates both the B and M keys for Socket 2/Socket 3 PCIe-based SSDs and follows the applicable PCIe M.2 specification. The signal/pin assignments and descriptions are listed in the following Table 13.

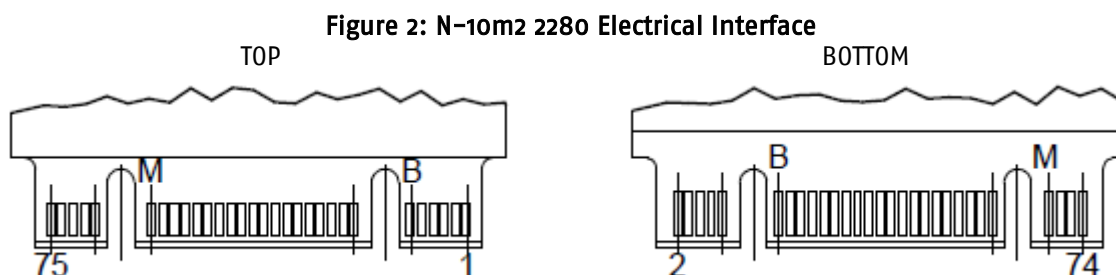

Table 13: Pin Assignment, Name and Description

Description	Assignment	Pin	Pin	Assignment	Description
Config_3	GND	1	2	+3.3V	3.3V Source
Ground	GND	3	4	+3.3V	3.3V Source
No Connect	NC	5	6	NC	No Connect
No Connect	NC	7	8	NC	No Connect
No Connect	NC	9	10	DAS/DSS	DEVACT Device Activity Signal
No Connect	NC	11	12-18	-	Mechanical Notch B
Mechanical Notch B	-	13-19	20	NC	No Connect
Config_o	GND	21	22	NC	No Connect
No Connect	NC	23	24	NC	No Connect
No Connect	NC	25	26	NC	No Connect
Ground	GND	27	28	NC	No Connect
PCIe TX Differential Signal	PETn1*	29	30	NC	No Connect ¹²
PCIe TX Differential Signal	PETp1*	31	32	NC	No Connect
Ground	GND	33	34	NC	No Connect
PCIe RX Differential Signal	PERn1*	35	36	NC	No Connect
PCIe RX Differential Signal	PERp1*	37	38	NC	No Connect
Ground	GND	39	40	(I/O)(o/1.8V)	SMB_CLK ¹³
PCIe TX Differential Signal	PETno*	41	42	(I/O)(o/1.8V)	SMB_DATA ¹³
PCIe TX Differential Signal	PETpo*	43	44	(O)(o/1.8V)	ALERT# ¹³
Ground	GND	45	46	NC	No Connect

¹² The write protect option is available on this pin upon request

¹³ According PCIe standard, SMBus pull-up resistors should be on host side. Optional Pull-ups on m.2 module are available on request

PCIe RX Differential Signal	PERno*	47	48	NC	No Connect
PCIe RX Differential Signal	PERpo*	49	50	PERST#	PE-Reset (Functional Reset)
Ground	GND	51	52	CLKREQ#	Clock Request Signal; L1 PM
PCIe Reference Clock Signal	REFCLKn	53	54	PEWAKE#	PCIe PME Wake
PCIe Reference Clock Signal	REFCLKp	55	56	DNU	Reserved (do not use)
Ground	GND	57	58	DNU	Reserved (do not use)
Mechanical Notch M	-	59-65	60-66	-	Mechanical Notch M
RESET#	NC	67	68	NC	32.768 kHz Clock Supply
Config_1	NC	69	70	3.3V	Supply Pin, 3.3V
Ground	GND	71	72	3.3V	Supply Pin, 3.3V
Ground	GND	73	74	3.3V	Supply Pin, 3.3V
Config_2	GND	75			

*TX (transmit) and RX (receive) pins are labeled from the SSD view and must be connected with the reversed RX and TX signals of the host (i.e., TX to RX and RX to TX).

6. Package Mechanical

Figure 3: N-10m2 2280 dimensions in mm [in]

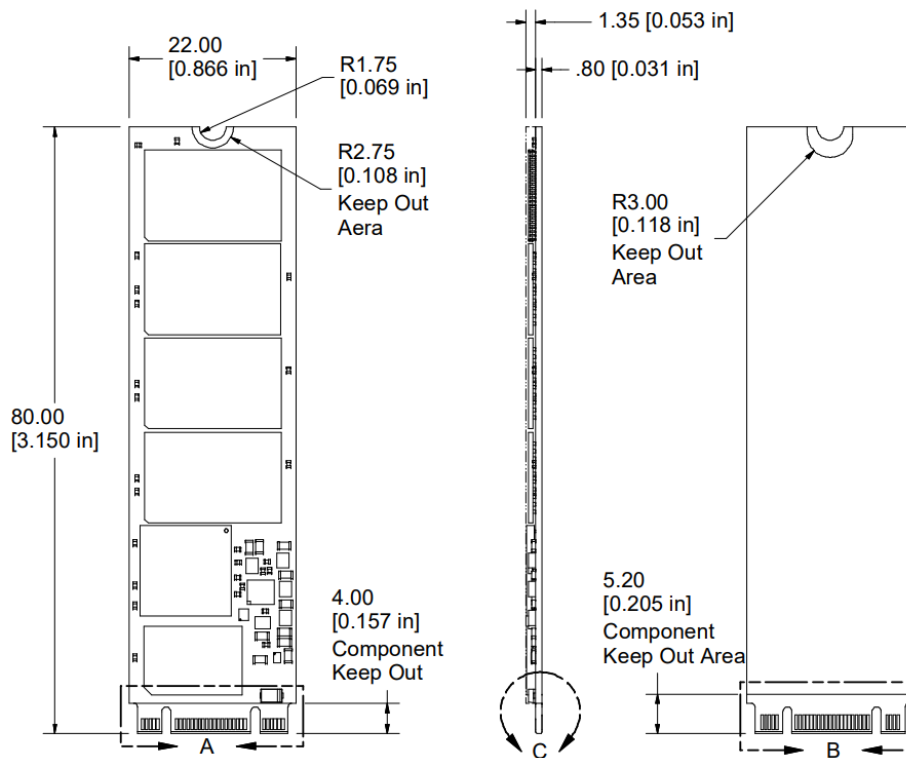
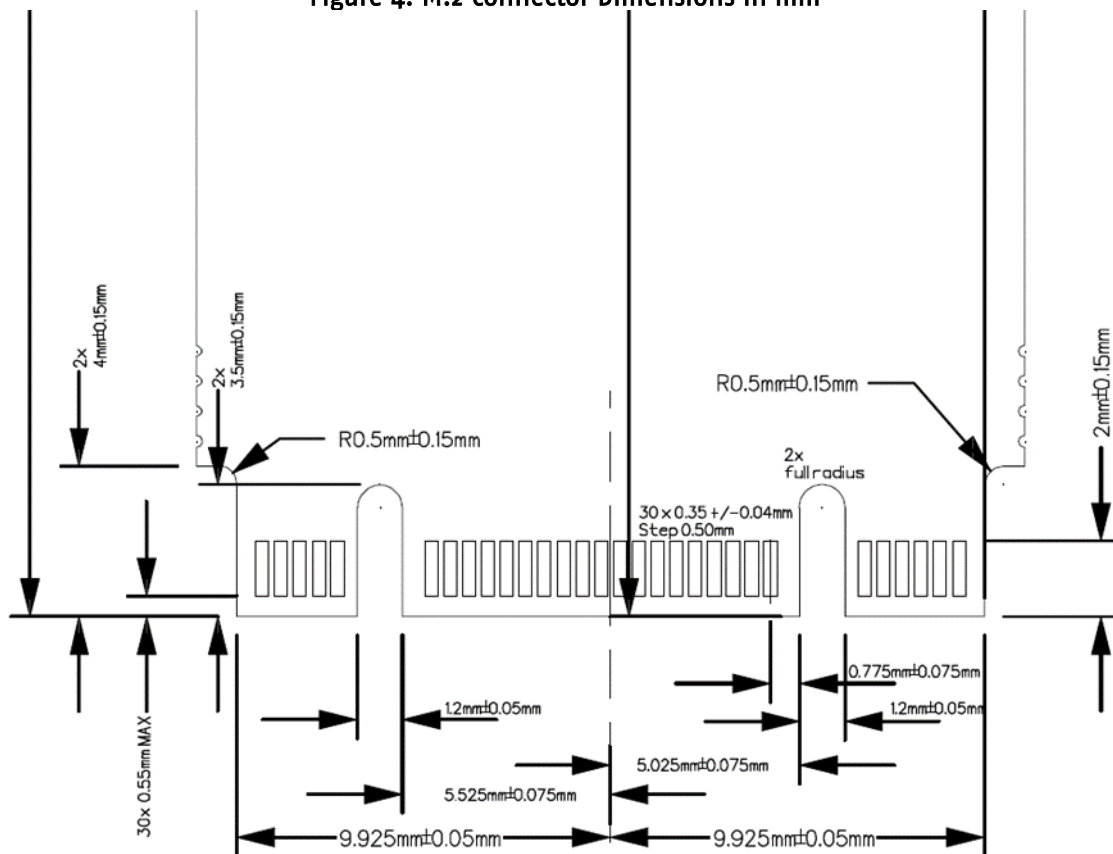

Figure 4: M.2 Connector Dimensions in mm



7. NVMe Commands

This section provides information on the NVMe commands supported by the SSD. The commands are issued by loading the DWords in the command block with the supplied parameter, and then writing the command code to the register. See the following Table 14 for a list of NVMe commands the device supports. For details about setting up the command registers, see the latest NVMe Specification.

Table 14: NVMe Command Set

Command	Code	Command	Code
Admin Commands			
Delete I/O Submission Queue	00h	Create I/O Submission Queue	01h
Get Log Page	02h	Delete I/O Completion Queue	04h
Create I/O Completion Queue	05h	Identify	06h
Abort	08h	Set Features	09h
Get Features	0Ah	Asynchronous Event Request	0Ch
Firmware Activate	10h	Firmware Image Download	11h
NVM Command-Specific Admin Commands			
Format NVM	80h	Security Send	81h
Security Receive	82h		
NVM Commands			
Flush	00h	Write	01h
Read	02h	Write Uncorrectable	04h
Compare	05h	Write Zeroes	08h
Dataset Management	09h		

8. Identify Device Information

The following table describes the 4096 bytes of data the drive returns for the Identify command (06h).

Table 15: Identify Device Information

Byte(s)	Default Value	Total Bytes	Data Field Type Information
0-1	1DD4h	2	PCI Vendor ID (VID)
2-3	1DD4h	2	PCI Subsystem Vendor ID (SSVID)
4-23	XXXXh*	20	Serial Number
24-63	XXXXh*	40	Model Number
64-71	XXXXh	8	Firmware Version
72	01h	1	Recommended Arbitration Burst (RAB)
73-75	0000h	3	IEE OUI Identifier
76	00h	1	Controller Multi-Path I/O and Namespace Sharing Capabilities (CMIC)
77	09h	1	Maximum Data Transfer Size (MDTS)
78-79	0000h	2	Controller ID (CID)
80-83	00010200h	4	Version
84-87	00124F80h	4	Runtime D3 Resume Latency
88-91	0016E360h	4	Runtime D3 Entry Latency
92-95	0000h	4	Optional Asynchronous Events Supported

Byte(s)	Default Value	Total Bytes	Data Field Type Information
96-99	00000000h	4	Controller Attributes (CTRATT)
96-255	0000h	160	Reserved
256-257	0007h	2	Optional Admin Command Support
258	00h	1	Abort Command Limit
259	03h	1	Asynchronous Event Request Limit
260	12h	1	Firmware Updates
261	04f	1	Log Page Attributes
262	0Fh	1	Error Log Page Entries
263	04h	1	Number of Power States Supported
264	01h	1	Admin Vendor-Specific Command Configuration
265	01h	1	Autonomous Power State Transition Attributes
266-267	XXXXh	2	Warning Composite Temperature Threshold in Degrees Kelvin
268-269	XXXXh	2	Critical Composite Temperature Threshold in Degrees Kelvin
270-271	0064h	2	Maximum Time for Firmware Activation
272-275	0000h	4	Host Memory Buffer Preferred Size
276-279	0000h	4	Host Memory Buffer Minimum Size
280-295	XXXXh	16	Total NVM Capacity
296-311	0000h	16	Unallocated NVM Capacity
312-315	0000h	4	Replay Protected Memory Block Support
316-319	0000h	4	Reserved
320-321	0000h	2	Keep Alive Support (KAS)
322-511	0000h	190	Reserved
512	66h	1	Submission Queue Entry Size
513	44h	1	Completion Queue Entry Size
514-515	0000h	2	Reserved
516-519	00000001h	4	Number of Namespaces
520-521	001Eh	2	Optional NVM Command Support
522-523	0000h	2	Fused Operation Support
524	050h	1	Format NVM Attributes
525	01h	1	Volatile Write Cache
526-527	00FFh	2	Atomic Write Unit Normal
528-529	0000h	2	Atomic Write Unit Power Fail
530	001h	1	NVM Vendor-Specific Command Configuration
531	00h	1	Reserved
532-533	0000h	2	Atomic Compare and Write Unit
534-535	0000h	2	Reserved
536-539	00000000h	4	Scatter Gather List (SGL) Support
540-767	0000h	228	Reserved
768-1023	0000h	256	NVM Subsystem NVMe Qualified Name (SUBNQN)

Byte(s)	Default Value	Total Bytes	Data Field Type Information
540-2047	0000h	1024	Reserved
2048-2079	XXXXh	32	Power State 0 Descriptor
2080-2111	XXXXh	32	Power State 1 Descriptor
2112-2143	XXXXh	32	Power State 2 Descriptor
2144-2175	XXXXh	32	Power State 3 Descriptor
2176-2207	XXXXh	32	Power State 4 Descriptor
2208-3071	0000h	896	Power State 5 - 31 Descriptor (Not Applicable)
3072-4095	0000h	1024	Reserved

* Standard values for full functionality are listed. Values depend on device configuration.

9. Health Monitoring Functionality

The N-10m2 2280 SSD supports health monitoring via attributes in log pages. These attributes reside in either the standard SMART Log Page with Log Identifier (LID) 02h or the Vendor Specific Page with LID Coh. To retrieve the vendor attributes, use the Get Log Page command (02h) with the Number of DWords field set to 7Fh and the LID field set to Coh. The drive returns one sector (512 bytes) of data. See the following Table 16 and Table 17 for the data structure of the standard SMART log page and of the Vendor Specific SMART log page.

Table 16: GetLogPage Data

Byte(s)	Value	Description
0	XXh	Critical warning for the state of the controller
1-2	XXXXh	Composite temperature, in degrees Kelvin
3	XXh	Available spares as a percentage of remaining spares
4	ooh	Available spare threshold
5	XXh	Estimate of the percentage of the NVM subsystem life left based on usage
6-31	ooh	Reserved
32-39	XXXXh	Number of 512-byte sectors read by the host (in 1000 increments)
40-47	XXXXh	Number of logical blocks read as part of compare and read operations
48-55	XXXXh	Number of 512-byte sectors written by the host (in 1000 increments)
56-63	XXXXh	Number of logical blocks written as part of the NVM Write command
64-79	XXXXh	Number of Read commands completed by the controller
80-95	XXXXh	Number of Write commands completed by the controller
96-111	XXXXh	Amount of time, in minutes, the controller was busy with I/O commands
112-127	XXXXh	Number of power cycles that has occurred over the life of the drive
128-143	XXXXh	Number of hours the device has been powered over the life of the drive (does not include the time the device is in low power state conditions)
144-159	XXXXh	Number of shutdowns that occurred without a shutdown notification
160-175	XXXXh	Number of unrecoverable errors, including UECC, CRC checksum failures, and LBA mismatches, that occurred over the life of the drive
176-191	XXXXh	Number of entries recorded in the Error Information log over the life of the drive

192-195	XXXXh	Amount of time, in minutes, the controller was operational and the Composite Temperature was equal to or greater than the Warning Composite Temperature Threshold but less than the Critical Composite Temperature Threshold
196-199	XXXXh	Amount of time, in minutes, the controller was operational and the Composite Temperature was equal to or greater than the Critical Composite Temperature Threshold
200-201	0000h	Not used
202-203	XXXXh	Current temperature, in degrees Kelvin, reported by temperature sensor 2
204-215	0000h	Not used
216-511	0000h	Reserved

Table 17: GetVendorLogPage Data

Byte(s)	Value	Description
0-3	XXXXh	Raw Read Error Rate – Logs total number of encountered read errors
4-5	XXXXh	Reallocated Sector Count – Logs total number of runtime identified bad blocks
8-23	XXXXh	Power On Hours – Logs total number of hours that drive is powered on
24-33	XXXXh	Power Cycle Count – Logs total number of power cycles that have occurred over the life of the drive
34-35	XXXXh	Initial Spare Blocks – Tracks the number of initial spare blocks; at the time of drive manufacturing
36-37	XXXXh	Available Spare Blocks – Logs total number of currently available (unallocated) spare blocks that are available for data
38-39	XXXXh	Remaining Spare Blocks – Logs total number of remaining space blocks; available or used
40-43	XXXXh	Uncorrectable Sector Count – Logs total number of sector reads with UECC errors
44-45	XXXXh	Initial Bad Blocks – Logs total number of bad blocks identified at time of drive manufacturing
48-55	XXXXh	Total D1 Erase Count – Logs total number of erase operations performed on a pSLC (D1) block
56-63	XXXXh	Total D3 Erase Count – Logs total number of erase operations performed on a TLC (D3) block
64-67	XXXXh	Max Erase Count – Logs the maximum number of erase operations performed on a single block
68-71	XXXXh	Min Erase Count – Logs the minimum number of erase operations performed on a single block
72-75	XXXXh	Avg. Erase Count – Logs the average number of erase operations performed across all blocks
76-79	oBB8h	Rated Erase Count – Logs rated number of erase operations
80-83	XXXXh	Power Fault Repair Count – Logs the number of repairs that have occurred during power on due to unexpected power loss
84-87	XXXXh	Dynamic Remaps – Logs total number of operations for which data is moved to refresh it
88-89	XXXXh	Temperature – Reports current operating temperature in degrees C (controller)
90-91	XXXXh	Max Temperature – Logs the maximum operating temperature in degrees C (controller)
92-93	XXXXh	Min Temperature – Logs the minimum operating temperature in degrees C (controller)
96-99	XXXXh	Flash ECC Recovered – Logs number of ECC events for which early move or early retire are required
100-101	XXXXh	Runtime Bad Blocks – Logs total number of bad blocks that have occurred after drive manufacturing
104-107	XXXXh	Background Uncorrectable Sector Count – Logs total number of UECCs identified during background scan
108-109	XXXXh	PHY CRC Error Count – Total count of CRC errors during communication via the interface cable

Byte(s)	Value	Description
110-111	0000h	Reserved
112-115	XXXXh	Deallocate Count – Logs total number of deallocate commands issued by host
116-119	0000h	Reserved
120-127	XXXXh	Total Flash LBAs Written – Logs total amount of data written to flash (in 512-byte increments)
128-143	XXXXh	Total Host LBAs Written – Logs total amount of data written to drive by host (in 512-byte increments)
144-159	XXXXh	Total Host LBAs Read – Logs total amount of data read from drive by host (in 512-byte increments)
160-163	XXXXh	SSD Remaining Life – Logs lifetime of drive remaining , as a percentage, based upon rated erase cycles
164	XXXXh	Firmware Instance – Logs number of valid firmware copies on drive at power on
165-167	0000h	Reserved
168-171	XXXXh	Firmware Refreshes – Logs number of firmware refreshes that have occurred
172-175	XXXXh	Firmware Update Counter – Logs number of firmware updates that have occurred
176-183	XXXXh	Temperature Throttling – Logs number of times that temperature throttling has been utilized
184-187	2710h	Read Disturb D1 – Logs rated number of read operations that occur in a pSLC (D1) flash block before a refresh is performed
188-191	9C40h	Read Disturb D3 – Logs rated number of read operations that occur in a TLC (D3) flash block before a refresh is performed
192-195	XXXXh	Read Disturb Refresh – Logs the number of page refresh operations (D1 or D3) that have been performed
196-199	XXXXh	Background Scan Trigger Count – Logs the number of times that background scan operations have been performed
200-203	XXXXh	Background Scan Refresh Count – Logs the number of times that refresh has been performed for a background scan
204-207	0B40h	Background Scan Idle Time To Trigger – Reports the threshold time for background scanning (minutes)
208-209	XXXXh	User Data – Logs the amount of the drive, as a percentage, that contains valid user data
210-211	0000h	Reserved
212	XXXXh	Spare Block Remaining Life – Logs the lifetime of the drive remaining , as a percentage, based upon rated spare blocks
213-511	0000h	Reserved

9.1 Log Pages Subcommands

The following Table 18 lists the supported log pages.

Table 18: Log Pages Supported

Log Page	Operation
02h	Log Page, Standard
C0h	Log Page, Vendor

10. Part Number Decoder

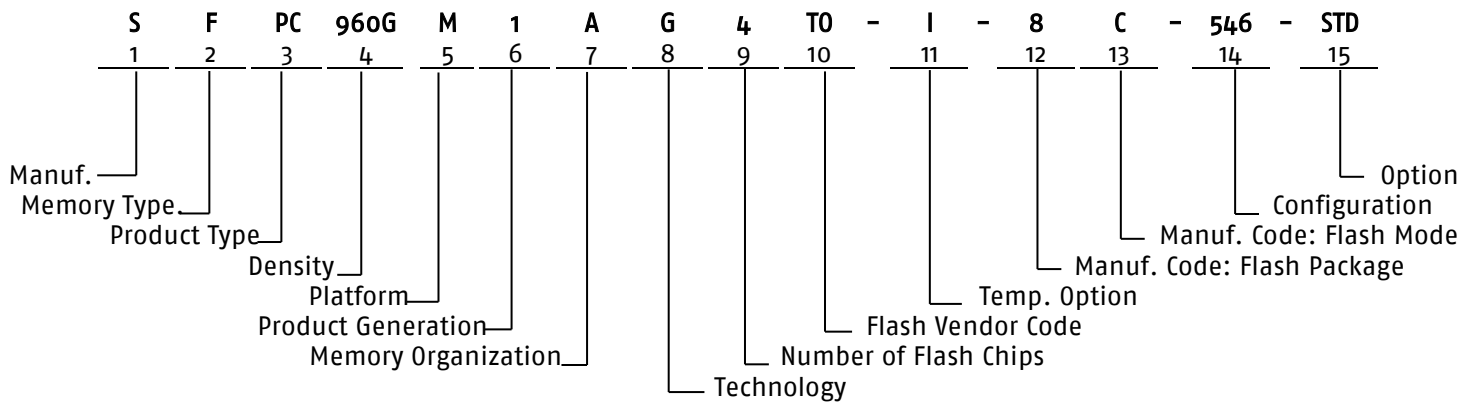

10.1 Manufacturer

Swissbit Code	S
---------------	---

10.2 Memory Type

Flash	F
-------	---

10.3 Product Type

PCIe Interface	PC
----------------	----

10.4 Density

120 GBytes	120G
240 GBytes	240G
480 GBytes	480G
960 GBytes	960G

10.5 Platform

M.2 SSD	M
---------	---

10.6 Product Generation

10.7 Memory Organization

x8	A
----	---

10.8 Technology

N-10m2 2280 Series	G
--------------------	---

10.9 Number of Flash Chips

1 Flash	1
2 Flash	2
4 Flash	4

10.10 Flash Code

Toshiba / Kioxia	T0
------------------	----

10.11 Temperature Option

Commercial Temperature Range: 0 °C to 70 °C	C
Industrial Temperature Range: -40 °C to 85 °C	I

10.12 Die Classification

3D TLC MONO (single die package)	5
3D TLC DDP (dual die package)	6
3D TLC QDP (quad die package)	7
3D TLC ODP (octal die package)	8

10.13 Pin Mode

	TSOP	BGA
Single nCE and Single R/nB	S	A
Dual nCE and Dual R/nB	T	B
Quad nCE and Quad R/nB	U	C
Octal nCE and Octal R/nB	*	V
Sexdec nCE & Sexdec R/nB	*	W

*Not Available

10.14 Drive configuration XYZ

X = Dimension and Assembly

Dimension	Assembly	X
2280	Single-Sided	5

Y = Firmware Revision

FW Revision	Y
SBR10021	4

Z = Feature

Feature	Z
Standard	6

10.15 Option

Standard	STD
----------	-----

11. Marking Specification

11.1 Top View

Figure 5: N-10m2 2280 top view

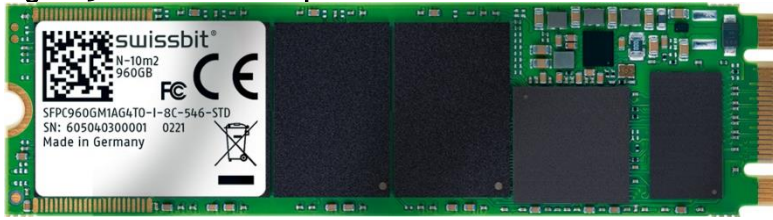

11.2 Print on the label

Figure 6: N-10m2 2280 label details

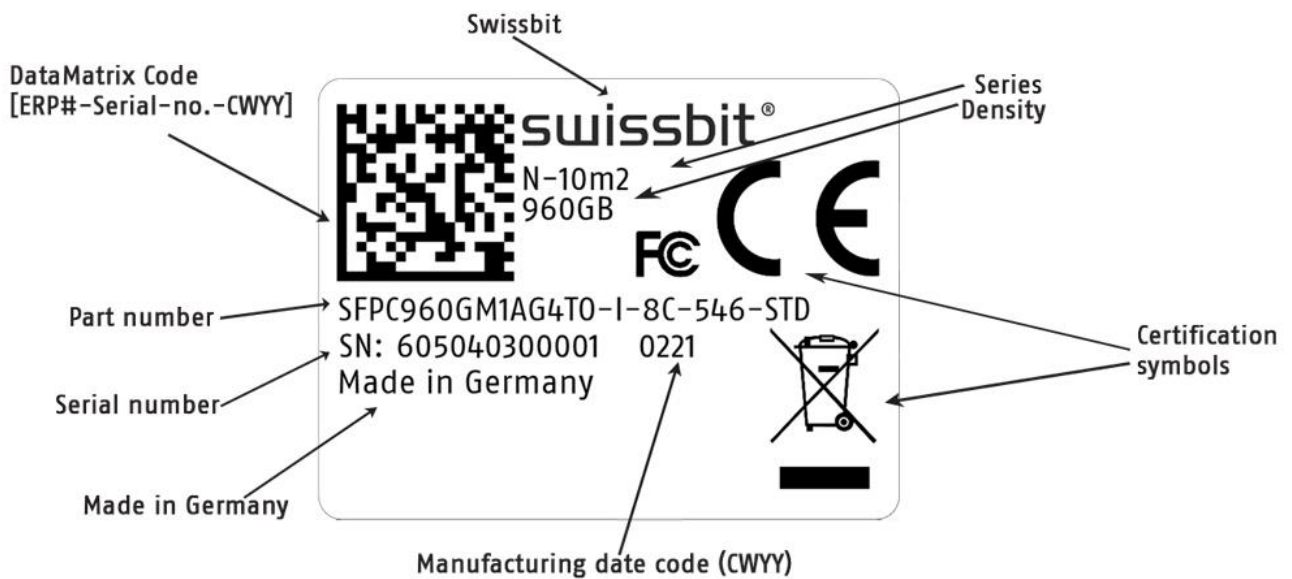

12. Revision History

Table 19: Document Revision History

Date	Revision	Description	Revision Details
17-May-2019	0.90	Preliminary draft	Doc-2933
28-May-2019	0.91	Added E2E data protection and part numbers, minor changes	Doc-2946
29-July-2019	1.00	Added FW revision, updated 120GB performance, minor changes	Doc-3085
25-Feb-2020	1.01	Added FW3 items	Doc-3482
27-Jan-2021	1.02	Added FW4 information and updated regulatory table, icons, and footnotes	Doc-4340

Disclaimer:

No part of this document may be copied or reproduced in any form or by any means, or transferred to any third party, without the prior written consent of an authorized representative of Swissbit AG ("SWISSBIT"). The information in this document is subject to change without notice. SWISSBIT assumes no responsibility for any errors or omissions that may appear in this document and disclaims responsibility for any consequences resulting from the use of the information set forth herein. SWISSBIT makes no commitments to update or to keep current information contained in this document. The products listed in this document are not suitable for use in applications such as, but not limited to, aircraft control systems, aerospace equipment, submarine cables, nuclear reactor control systems and life support systems. Moreover, SWISSBIT does not recommend or approve the use of any of its products in life support devices or systems or in any application where failure could result in injury or death. If a customer wishes to use SWISSBIT products in applications not intended by SWISSBIT, said customer must contact an authorized SWISSBIT representative to determine SWISSBIT willingness to support a given application. The information set forth in this document does not convey any license under the copyrights, patent rights, trademarks or other intellectual property rights claimed and owned by SWISSBIT. The information set forth in this document is considered to be "Proprietary" and "Confidential" property owned by SWISSBIT.

ALL PRODUCTS SOLD BY SWISSBIT ARE COVERED BY THE PROVISIONS APPEARING IN SWISSBIT'S TERMS AND CONDITIONS OF SALE ONLY, INCLUDING THE LIMITATIONS OF LIABILITY, WARRANTY AND INFRINGEMENT PROVISIONS. SWISSBIT MAKES NO WARRANTIES OF ANY KIND, EXPRESS, STATUTORY, IMPLIED OR OTHERWISE, REGARDING INFORMATION SET FORTH HEREIN OR REGARDING THE FREEDOM OF THE DESCRIBED PRODUCTS FROM INTELLECTUAL PROPERTY INFRINGEMENT AND EXPRESSLY DISCLAIMS ANY SUCH WARRANTIES INCLUDING WITHOUT LIMITATION ANY EXPRESS, STATUTORY OR IMPLIED WARRANTIES OF MERCHANTABILITY OR FITNESS FOR A PARTICULAR PURPOSE.

© 2021 SWISSBIT AG All rights reserved.