



CONDUCTIVE POLYMER ALUMINUM SOLID CAPACITORS

CAT. No. E1001I (Ver.2)

INDEX		
PRODUCT SEARCH	SERIES TABLE	➔
	GROUP CHART	➔
PRODUCTION GUIDE	PRECAUTIONS AND GUIDELINES (Conductive Polymer)	➔
	PART NUMBERING SYSTEM	➔
	ENVIRONMENTAL CONSIDERATION	➔
	PACKAGING	➔
	TAPING SPECIFICATIONS	➔
	RECOMMENDED REFLOW CONDITION	➔
	STANDARDIZATION	➔
	WORLD-WIDE MANUFACTURING LOCATIONS	➔
PRODUCT SPECIFICATIONS	CONDUCTIVE POLYMER TYPE	➔
RELIABILITY DATA		➔
APPENDIX (GLOBAL CODE)		➔

Series		Features	Endurance (+R=With ripple)	Standard type	Low impedance	Solvent resistant	Terminal type	Rated voltage range (V _{dc})	Capacitance range (μF)	
Conductive Polymer Electrolyte Type	PXS <small>(NEW!)</small>	Chip type, super low ESR, long life	105°C 5,000 hours		●	●	SMD	4 to 16	22 to 560	
	PXF	Chip type, super low ESR	105°C 2,000 hours		●	●	SMD	2.5 to 6.3	220 to 1,000	
	PXE <small>(Upgrade!)</small>	Chip type, super low ESR	105°C 2,000 hours		●	●	SMD	2.5 to 16	33 to 2,700	
	PXA	Chip type, super low ESR	105°C 1,000 to 2,000 hours	●	●	●	SMD	2.5 to 25	3.3 to 1,500	
	PXH	125°C Vertical type	125°C 1,000 hours		●	●	SMD	2.5 to 20	22 to 1,000	
	PSF <small>(NEW!)</small>	Radial type, super low ESR, long life	105°C 5,000 hours		●	●	Radial	2.5 to 16	100 to 560	
	PSE <small>(NEW!)</small>	Radial type, super low ESR, long life	105°C 5,000 hours		●	●	Radial	2.5 to 6.3	470 to 820	
	PSC	Radial lead type, super low ESR, high ripple current	105°C 2,000 hours		●	●	Radial	2.5 to 16	270 to 2,700	
	PSA	Super low ESR, high ripple current	105°C 2,000 hours		●	●	Radial	2.5 to 16	47 to 1,500	
	PS	Radial lead type, super low ESR	105°C 2,000 hours	●	●	●	Radial	2.5 to 35	18 to 1,500	
	PSL <small>(NEW!)</small>	Low ESL (Ask Engineering Bulletin No791 in detail)	105°C 2,000 hours		●	●	Radial	2.5	330 & 560	
Miniature Surface Mount	Vertical Type	MVS	4.5mm height	85°C 2,000 hours	●	●	SMD	4 to 50	0.1 to 220	
		MVA	5.5 to 22.0mm max. height, downsized	85°C 2,000 hours		▲	SMD	4 to 450	0.1 to 10,000	
		MV	5.5 to 10.5mm max. height	85°C 1,000 to 2,000 hours	●	●	SMD	4 to 63	0.1 to 1,000	
		MVE	5.5 to 22.0mm max. height, downsized	105°C 1,000 to 2,000 hours		▲	SMD	6.3 to 450	0.47 to 6,800	
		MVK	5.5 to 10.5mm max. height	105°C 1,000 to 2,000 hours	●	●	SMD	6.3 to 50	0.1 to 1,000	
		MZA	6.1 to 10.5mm max. height, very low impedance	105°C 2,000 hours		●	●	SMD	6.3 to 80	3.3 to 1,500
		MVY	5.5 to 22.0mm max. height	105°C 1,000 to 5,000 hours		●	▲	SMD	6.3 to 100	1.0 to 8,200
		MZF <small>(NEW!)</small>	105°C10,000 hours, Low impedance, Long life (Ask Engineering Bulletin No794 in detail)	105°C 10,000 hours		●	●	SMD	6.3 to 50	10 to 470
		MZE	105°C7,000/8,000 hours, low impedance, long life	105°C 7,000 to 8,000 hours		●	●	SMD	6.3 to 50	10 to 470
		MZD	105°C5,000 hours, low impedance, long life (Ask Engineering Bulletin No758 in detail)	105°C 5,000 hours		●	●	SMD	6.3 to 50	10 to 470
		MLA	Low impedance, long life	105°C 3,000 hours		●	●	SMD	6.3 to 50	10 to 1,000
		MVJ	6.0mm max. height	105°C 2,000 hours			●	SMD	6.3 to 50	0.1 to 100
		MLF <small>(NEW!)</small>	105°C10,000 hours, Long life (Ask Engineering Bulletin No793 in detail)	105°C 10,000 hours			●	SMD	6.3 to 50	0.1 to 1,000
		MLE	105°C7,000/8,000 hours, long life	105°C 7,000 to 8,000 hours			●	SMD	6.3 to 50	0.1 to 1,000
		MLD	105°C5,000 hours, long life (Ask Engineering Bulletin No759 in detail)	105°C 5,000 hours			●	SMD	6.3 to 50	0.1 to 1,000
		MVL	6.0 to 10.5mm max. height	105°C 3,000 to 5,000 hours			●	SMD	6.3 to 50	0.1 to 1,000
		MVH	6.0 to 22.0mm max. height	125°C 1,000 to 5,000 hours			▲	SMD	10 to 450	3.3 to 4,700
		MHB	10.5mm max. height	125°C 2,000 hours			●	SMD	10 to 35	47 to 470
		MKB	10.5mm max. height	105°C 3,000 hours				SMD	400	2.2 to 4.7
		MV-BP	5.5mm max. height, bi-polar	85°C 2,000 hours			●	SMD	4 to 50	0.1 to 47
MVK-BP	6.0mm max. height, bi-polar	105°C 1,000 hours			●	SMD	6.3 to 50	0.1 to 47		
Miniature	Low Profile	SRM	5mm height, downsized	85°C 1,000 hours		●	Radial	4 to 50	0.1 to 330	
		SRE	5mm height	85°C 1,000 hours	●		Radial	4 to 50	0.1 to 100	
		KRE	5mm height	105°C 1,000 hours	●	●	Radial	6.3 to 50	0.1 to 100	
		SRA	7mm height	85°C 1,000 hours	●		Radial	4 to 63	0.1 to 470	
		KMA	7mm height	105°C 1,000 hours	●	●	Radial	4 to 63	0.1 to 220	
		SRG	φ4×7 to φ18×25mm, low profile	85°C 1,000 to 2,000 hours			●	Radial	4 to 50	0.1 to 10,000
		KRG	φ4×7 to φ18×25mm, low profile	105°C 1,000 hours			●	Radial	6.3 to 50	0.1 to 10,000
	General Purpose	SMQ	Downsized	85°C 2,000 hours	●			Radial	6.3 to 450	0.1 to 47,000
		KMQ	Downsized	105°C 1,000 to 2,000 hours +R	●	▲		Radial	6.3 to 450	0.1 to 47,000
		SMG	General, downsized	85°C 2,000 hours	●	▲		Radial	6.3 to 450	0.1 to 39,000
		KMG	General, downsized	105°C 1,000 to 2,000 hours +R	●	▲		Radial	6.3 to 450	0.1 to 22,000
		SME-BP	Bi-polar, general	85°C 2,000 hours	●	●		Radial	6.3 to 100	0.47 to 6,800
		KME-BP	Bi-polar, general	105°C 1,000 hours	●	●		Radial	6.3 to 100	0.47 to 6,800
	High Frequency Use	KZM	Lowest impedance, long life	105°C 6,000 to 10,000 hours +R	●			Radial	6.3 to 50	27 to 10,000
		KZH	Lowest impedance, long life	105°C 5,000 to 6,000 hours +R	●			Radial	6.3 to 35	47 to 8,200
		KZE	Lowest impedance, long life	105°C 1,000 to 5,000 hours +R	●			Radial	6.3 to 100	6.8 to 6,800
		KY	Low impedance, long life	105°C 4,000 to 10,000 hours +R	●			Radial	6.3 to 100	0.47 to 18,000
LXZ		Low impedance, downsized	105°C 2,000 to 8,000 hours +R		●	●	Radial	6.3 to 63	12 to 18,000	
LXY		Low impedance, high reliability	105°C 2,000 to 8,000 hours +R	●	●	●	Radial	10 to 63	10 to 8,200	
LXV		Low impedance	105°C 2,000 to 5,000 hours +R		●	●	Radial	6.3 to 100	5.6 to 15,000	

■ : Promotional products

▲ : Some of range are solvent resistant.

Series		Features	Endurance (+R=With ripple)	Standard type	Low impedance	Solvent resistant	Terminal type	Rated voltage range (Vdc)	Capacitance range (μF)	
Miniature	High Reliability	KXJ	Downsized, long life, for input filtering	105°C 10,000 to 12,000 hours +R	●		Radial	160 to 450	6.8 to 680	
		KXG	Downsized, long life, for input filtering	105°C 8,000 to 10,000 hours +R	●		Radial	160 to 450	6.8 to 330	
		SMH	φ20×20 to φ22×50mm	85°C 2,000 hours +R	●		Radial	160 to 450	33 to 470	
		KMH	φ20×20 to φ22×50mm	105°C 2,000 hours +R	●		Radial	160 to 450	33 to 470	
		PAG	Low profile, for input filtering	105°C 2,000 hours +R			Radial	200 to 450	18 to 560	
		KLJ	Downsized, no sparks with DC overvoltage	105°C 2,000 hours +R			Radial	200 & 400	4.7 to 330	
		KLG	No sparks with DC overvoltage	105°C 2,000 hours +R			Radial	200 & 400	22 to 330	
		FL	Long life	105°C 3,000 hours +R		●	Radial	6.3 to 50	0.47 to 270	
		GPA	125°C, downsized, low impedance	125°C 3,000 to 5,000 hours +R	●	●	Radial	25 to 50	470 to 6,800	
		GXE	125°C, downsize, low impedance	125°C 2,000 to 5,000 hours +R	●	▲	Radial	10 to 450	4.7 to 4,700	
	GXL	125°C Long life	125°C 5,000 hours +R		●	Radial	10 to 50	100 to 1,000		
	Special Application	LBG	For airbag	105°C 5,000 hours +R		●	●	Radial	25 & 35	1,000 to 11,000
		KZG	For PC motherboard (Ask Engineering Bulletin No705 in detail)	105°C 2,000 hours +R		●		Radial	6.3 to 16	470 to 3,300
		LLA	Low DC leakage, general	85°C 1,000 hours			●	Radial	6.3 to 50	0.1 to 15,000
PH		For photo flash	55°C 5,000 times charging				Radial	300 & 330	—	
Snap-in	General Purpose	KMR	105°C, Snap-in terminal, super downsized	105°C 2,000 hours +R	●		Pin	160 to 450	100 to 3,300	
		SMQ	Snap-in terminal, more downsized	85°C 2,000 hours +R	●		Pin	160 to 450	82 to 3,900	
		KMQ	Snap-in terminal, more downsized	105°C 2,000 hours +R	●		Pin	35, 50, 160 to 450	68 to 33,000	
		SMM	Snap-in terminal, downsized	85°C 3,000 hours +R	●		Pin	160 to 450	47 to 3,300	
		KMS	Snap-in terminal, downsized	105°C 3,000 hours +R	●		Pin	160 to 450	82 to 3,300	
		KMM	Snap-in terminal, downsized	105°C 2,000 to 3,000 hours +R	●		Pin	160 to 450	39 to 3,300	
		SMH	Snap-in terminal, general (Ask Engineering Bulletin No585 for 160 to 450V)	85°C 2,000 hours +R	●		Pin	6.3 to 100	820 to 100,000	
	Low Profile	KMH	Snap-in terminal, general (Ask Engineering Bulletin No584 for 160 to 450V)	105°C 2,000 hours +R	●		Pin	6.3 to 100	560 to 82,000	
		SLM	15mm height	85°C 2,000 hours +R			Pin	160 to 400	47 to 560	
	High Reliability	KLM	15mm height	105°C 2,000 hours +R			Pin	160 to 400	39 to 390	
		LXM	Long life	105°C 7,000 hours +R			Pin	160 to 450	47 to 2,200	
		LXS	Snap-in terminal downsized	105°C 5,000 hours +R	●		Pin	160 to 450	82 to 3,300	
		LXQ	Long life, downsized	105°C 5,000 hours +R			Pin	160 to 450	82 to 2,700	
		LXG	Long life	105°C 5,000 hours +R			Pin	10 to 100	390 to 47,000	
		CHA	No sparks with DC overvoltage, downsized	105°C 2,000 hours +R			Pin	200 to 450	56 to 1,200	
		LXH	No sparks with DC overvoltage	105°C 3,000/5,000 hours +R			Pin	200 & 400	68 to 1,500	
	KMV (NEW)	For charge and discharge application (Ask Engineering Bulletin No781 in detail)	105°C 3,000 hours +R			Pin	350 to 450	82 to 1,200		
	Screw-mount	General Purpose	SME	Screw terminal, general	85°C 2,000 hours +R	●		Screw	10 to 250	560 to 680,000
KMH			Screw terminal, general	105°C 2,000 hours +R	●		Screw	10 to 400	180 to 680,000	
For Inverter		RWG	85°C, high ripple, downsized, long life	85°C 5,000 hours +R			Screw	350 to 450	1,500 to 18,000	
		RWF	High ripple, long life	85°C 5,000 hours +R			Screw	350 to 450	820 to 22,000	
		RWG (NEW)	High ripple, downsized	85°C 2,000 hours +R	●		Screw	350 to 550	390 to 15,000	
		RWE	High ripple	85°C 2,000 hours +R	●		Screw	350 to 550	100 to 12,000	
		RWY	High ripple, long life, low cost	85°C 5,000 hours +R			Screw	350 to 450	500 to 14,000	
		RWL	High ripple, long life	85°C 20,000 hours +R			Screw	350 to 450	2,200 to 12,000	
		FTP	Ellips can shape, high ripple	85°C 5,000 hours +R			Screw	63 to 450	270 to 21,000	
		LXA	Long life	105°C 2,000/5,000 hours +R			Screw	10 to 525	330 to 390,000	
		LXR	High ripple, long life	105°C 5,000 hours +R			Screw	350 to 450	2,200 to 15,000	
		RWW (NEW)	For charge and discharge application (Ask Engineering Bulletin No782 in detail)	85°C 5,000 hours +R			Screw	350 to 450	820 to 18,000	

■ : Promotional products

▲ : Some of range are solvent resistant.

CONDUCTIVE POLYMER ALUMINUM SOLID CAPACITORS

◆SURFACE MOUNT

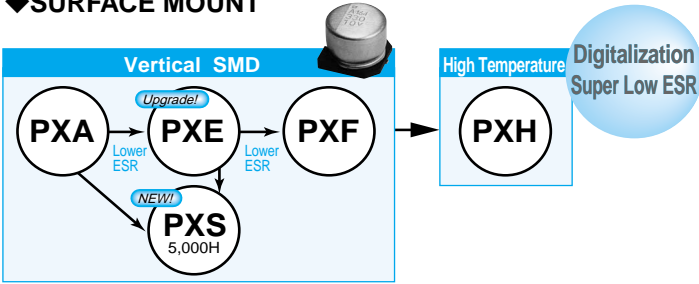

◆RADIAL LEAD

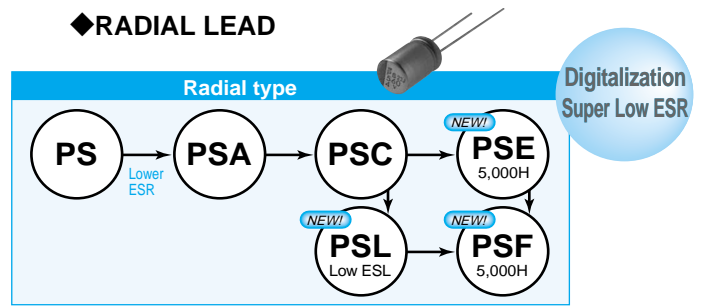

ALUMINUM ELECTROLYTIC CAPACITORS

◆SURFACE MOUNT

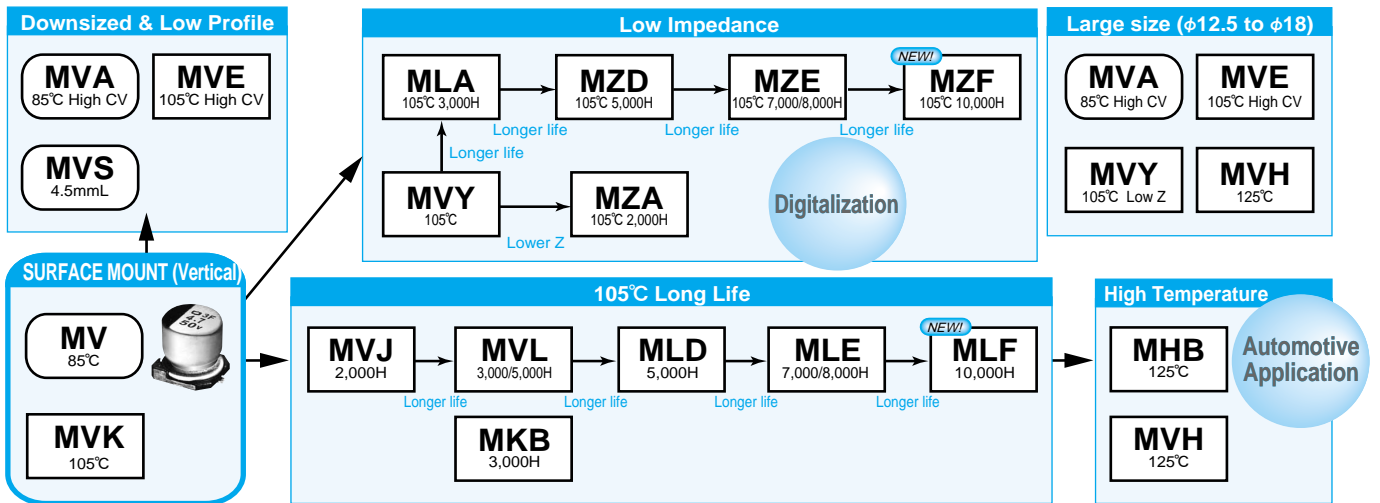

◆RADIAL LEAD

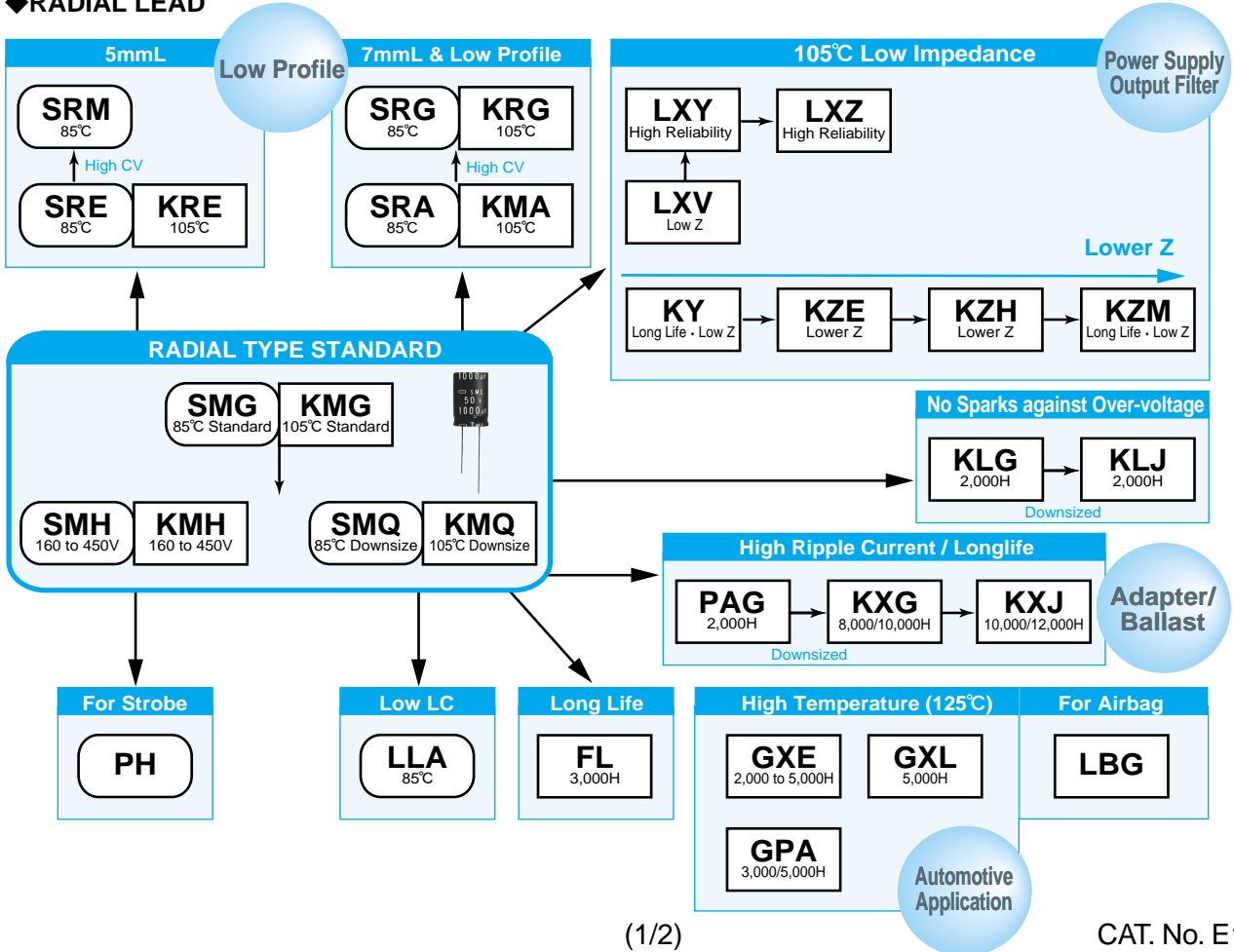



PART NUMBERING SYSTEM

Part numbering system

Our part numbering system is common to all of Nippon Chemi-Con's subsidiaries worldwide, and has been switching the conventional part numbering system. The part number uses 18-digit codes to express information of principal product specifications such as product category, series name, rated voltage, capacitance, case size and RoHS compliance.

●Categories

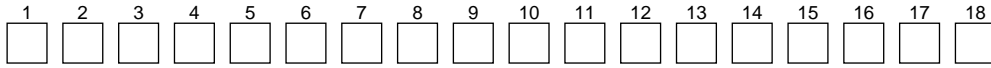

Code	Details
A	Conductive Polymer Aluminum Solid Capacitors (Polar)
E	Aluminum Electrolytic Capacitors (Polar)
B	Aluminum Electrolytic Capacitors (Bi-polar)
K	Multilayer Ceramic Capacitors
F,W	Film Capacitors
D	Electric Double Layer Capacitors
T	Metal Oxide Varistors
L	Amorphous Choke Coils

* For digits 2 to 18, please see "Product code guide".

●Example

Product type	Part number (Example)	Conventional part number (Ref.)
Surface mount type	EMV-160ADA100MD55G	MV16VC10MD55E0
Radial lead type	ESMG6R3ETC102MHB5D	TC04RSMG6. 3VB1000MF50E0
Snap-in type	ESMQ201VSN471MP30S	SMQ200VSSN470M22BE0
Screw mount terminal type	ERWE551LGC821MCD0M	RWE550LGSN820MCC13EA



Environment friendly capacitors

Nippon Chemi-Con always considers the environment in product materials, designs and manufacturing. In fact, our factories already have received ISO 14000 certificate. Cadmium, Mercury, Hexavalent Chromium, PBB and PBDE have never been used in our products. Furthermore, lead-containing materials have been eliminated from all our aluminum electrolytic capacitors including Conductive Polymer Aluminum Solid Capacitors to comply with RoHS. If you need "Halogen-Free" products, please consult with us.

◆Lead free and Non-PVC Products

1. Lead wire (Plating)

Category		Plating material on lead wires	
		Original type	Lead-free type
Chip	case code : B55 to JA0	Sn-Pb	Sn-Bi
	case code : KE0 to MN0		Sn100%
Radial	case dia : ~φ8		Sn-Bi
	case dia : φ10~		Sn100%
Snap-in			Sn100%
Screw-Mount			Originally lead free

*Please consult with us when you need "Lead-free parts" other than the above mentioned terminal plating materials.

(Note) **Pb** : lead, **Sn** : Tin, **Bi** : Bismuth

2. Sleeve

Category		Sleeve material	
		Original type	Lead-free type
Chip		Sleeveless(Resin case)	Sleeveless(Resin case)
Radial	φ8X5L	Sleeveless(Coating case)	Sleeveless(Coating case)
	except φ8X5L	PVC	PET
Snap-in		PVC	PET
Screw-Mount		PVC	PVC(Lead-free)

* Please consult with us when you need "Non-PVC parts" other than the above mentioned outer sleeve materials.

The colors of a PET sleeve are "Black", "Brown", and "Dark blue".

Standard designs of "lead-free" Snap-in type are not equipped with a plastic disc.

Please consult with us when you need nonflammable grade for outer sleeve material.

Identification of friendly parts is given by a supplement code (18th digit) of the part number.

For details, please refer to "Product code guide" for each type.

◆Regarding compliance for European REACH Regulation

According to the content of RIP3.8TGD (Technical Guidance Document) which is published on 26 May 2008, our electronic components are "articles without any intended release". Therefore they are not applicable for "Registration" for European REACH Regulation Article 7 (1).

Reference: Electrolytic Condenser Investigation Society

"Study of REACH Regulation in EU about Electrolytic Capacitor" (publicized on 13 March 2008)

TAPING SPECIFICATIONS

SURFACE MOUNT TYPE (TAPING)



◆CARRIER TAPE [mm]

Fig.1

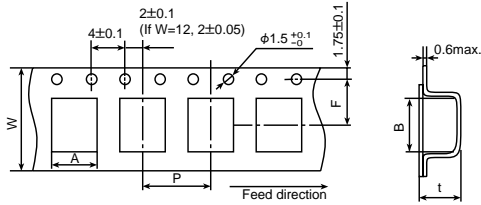

Fig.3

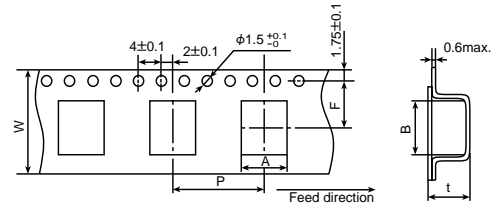

Fig.2

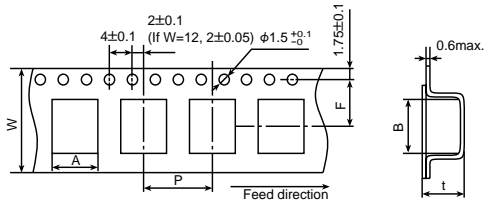
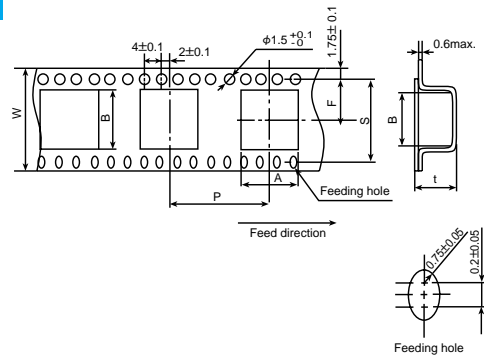

Fig.4



[mm]

Series	Items	W	A	B	F	P	t	S	Fig.
		±0.3	±0.2	±0.2	±0.1	±0.1	±0.2	±0.1	
Alchip™ MVS/MVA MV/MVE MVK/MZA MVY/MZF MZE/MZD MLA/MVJ MLF/MLE MLD/MVL MVH/MHB MKB/MV-BP MVK-BP	B55	12.0	3.5	3.5	5.5	8.0	5.9	—	1
	D46	12.0	4.7	4.7	5.5	8.0	4.9	—	1
	D55	12.0	4.7	4.7	5.5	8.0	5.7	—	1
	D60,D61	12.0	4.7	4.7	5.5	8.0	6.3	—	1
	D73	12.0	4.7	4.7	5.5	8.0	7.5	—	1
	E46	12.0	5.7	5.7	5.5	12.0	4.9	—	2
	E55	12.0	5.7	5.7	5.5	12.0	5.7	—	2
	E60,E61	12.0	5.7	5.7	5.5	12.0	6.3	—	2
	E73	16.0	5.7	5.7	7.5	12.0	7.5	—	2
	F45	16.0	7.0	7.0	7.5	12.0	4.8	—	2
	F46	16.0	7.0	7.0	7.5	12.0	4.9	—	2
	F55	16.0	7.0	7.0	7.5	12.0	5.7	—	2
	F60,F61	16.0	7.0	7.0	7.5	12.0	6.3	—	2
	F73	16.0	7.0	7.0	7.5	12.0	7.5	—	2
	F80	16.0	7.0	7.0	7.5	12.0	8.2	—	2
	F90	16.0	7.0	7.0	7.5	12.0	9.2	—	2
	H63	16.0	8.7	8.7	7.5	12.0	6.8	—	2
	H70	24.0	8.7	8.7	11.5	12.0	7.3	—	2
	H80	24.0	8.7	8.7	11.5	12.0	8.3	—	2
	NPCAP™ PXS/PXF PXE/PXA PXH	HA0	24.0	8.7	8.7	11.5	16.0	11.0	—
HC0		24.0	8.7	8.7	11.5	16.0	12.7	—	3
J80		24.0	10.7	10.7	11.5	16.0	8.3	—	3
JA0		24.0	10.7	10.7	11.5	16.0	11.0	—	3
JC0		24.0	10.7	10.7	11.5	16.0	12.8	—	3
KE0		32.0	13.4	13.4	14.2	24.0	14.0	28.4	4
KG5		32.0	13.4	13.4	14.2	24.0	16.5	28.4	4
LH0		44.0	17.5	17.5	20.2	28.0	16.8	40.4	4
LN0		44.0	17.5	17.5	20.2	28.0	22.1	40.4	4
MH0		44.0	19.5	19.5	20.2	32.0	17.1	40.4	4
MN0	44.0	19.5	19.5	20.2	32.0	22.1	40.4	4	

* Regarding to taping for LH0/LN0/MH0/MN0, please consult with us.

◆ REEL DIMENSIONS [mm]

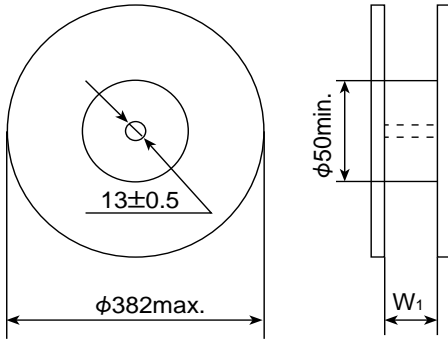

◆ POLARITY

- Alchip™- MVS/MVA/MV
MVE/MVK/MZA
MVY/MZF/MZE
MZD/MLA/MVJ
MLF/MLE/MLD
MVL/MVH/MHB
MKB/MV-BP
MVK-BP
NP CAP™ PXS/PXF/PXE
PXA/PXH

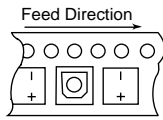

◆ QUANTITY PER REEL/BOX

Series	Size code	Quantity (pcs/reel)	Quantity (pcs/box)	W ₁ (mm)
Alchip™	B55	2,000	10,000	14
	D46,D55,D60,D61	2,000	10,000	14
	D73	1,500	7,500	14
	E46,E55,E60,E61	1,000	5,000	14
	E73	1,000	5,000	18
	F46,F55,F60,F61,F73	1,000	5,000	18
	F80	900	4,500	18
	F90	800	4,000	18
	H63	1,000	5,000	18
	HA0	500	1,500	26
	JA0	500	1,500	26
	KE0	200	600	34
	KG5	150	450	34
	LH0	125	250	46
	LN0	75	150	46
	MH0	125	250	46
	MN0	75	150	46
	NPCAP™	D55	2,000	20,000
E60,E61		1,000	10,000	14
F45,F55,F60,F61		1,000	7,000	18
F80		900	6,300	18
H70		1,000	6,000	26
H80		900	5,400	26
HA0		500	3,000	26
HCO		400	1,200	26
J80		500	3,000	26
JA0		500	3,000	26
JCO		400	1,200	26

SURFACE MOUNT TYPE (TRAY)

◆ DIMENSIONS [mm]

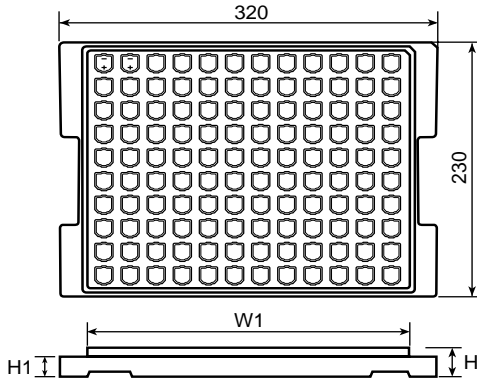

● TRAY CODE : TR

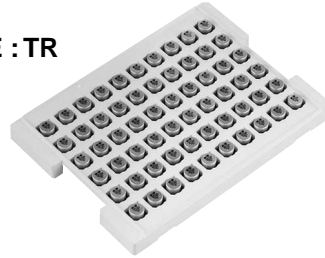

Size code	H [mm]	W ₁ [mm]	H ₁ [mm]	Quantity [pcs/tray]	Quantity [pcs/box]
KE0 & KG5	21.0	284	18.5	120	600
LH0 & LN0	28.0	284	24.0	80	400
MH0 & MN0	28.0	284	24.0	60	300

VIBRATION RESISTANT STRUCTURE (Terminal code : G)

◆ DIMENSIONS [mm]

- Terminal code : G
- Size code : HA0 to JA0

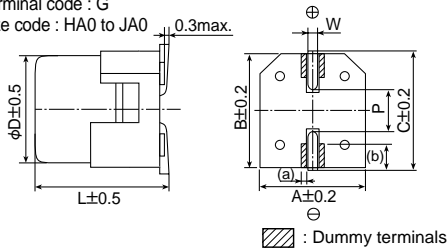

◆ RECOMMENDED SOLDER LAND

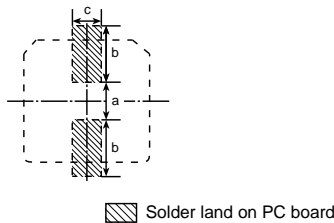

- Size code : KE0 to MN0

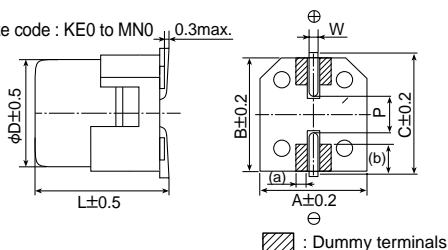

Size code	Dimensions of products (mm)									Solder land (mm)		
	D	L	A	B	C	W	P	(a)	(b)	a	b	c
HA0	8.0	10.0	8.3	8.3	9.0	0.7 to 1.1	3.1	(0.5)	(1.8)	3.1	4.2	3.5
JA0	10.0	10.0	10.3	10.3	11.0	0.7 to 1.1	4.5	(0.5)	(2.1)	4.5	4.4	3.5
KE0	12.5	13.5	13.0	13.0	13.7	1.0 to 1.3	4.2	(1.3)	(3.0)	3.4	6.3	9.3
KG5	12.5	16.0	13.0	13.0	13.7	1.0 to 1.3	4.2	(1.3)	(3.0)	3.4	6.3	9.3
LH0	16.0	16.5	17.0	17.0	18.0	1.0 to 1.3	6.5	(2.0)	(3.0)	4.7	7.8	9.6
LN0	16.0	21.5	17.0	17.0	18.0	1.0 to 1.3	6.5	(2.0)	(3.0)	4.7	7.8	9.6
MH0	18.0	16.5	19.0	19.0	20.0	1.0 to 1.3	6.5	(2.0)	(4.0)	4.7	8.8	9.6
MN0	18.0	21.5	19.0	19.0	20.0	1.0 to 1.3	6.5	(2.0)	(4.0)	4.7	8.8	9.6

() ; Ref.

TAPING SPECIFICATIONS
RADIAL LEAD TYPE (TAPING)



◆DIMENSION [mm]

Fig.1

Taping Code : TA, TC
φD=φ4 to 8

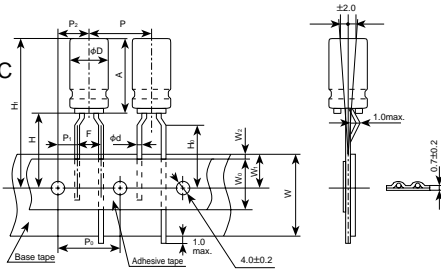

Fig.2

Taping Code : TD
φD=φ5
φD×L=φ4×7

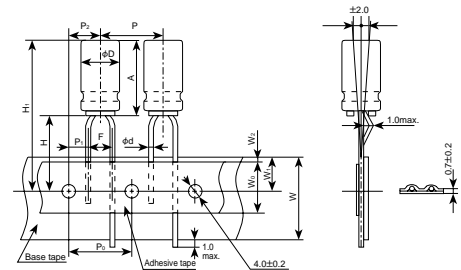

Fig.3

Taping Code : TD
φD=φ6.3 to 12.5

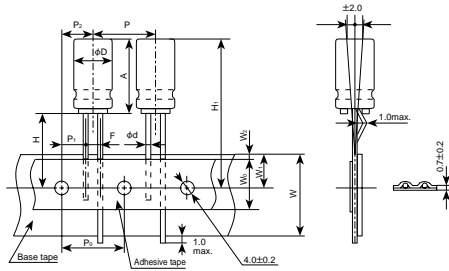
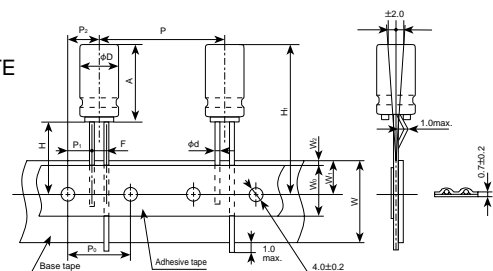

Fig.4

Taping Code : TE
φD=φ12.5



Code	Taping Code	Case size		φd	P	P ₀	P ₁	P ₂	F	W	W ₀	W ₁	W ₂	H	H ₀	H ₁	Fig.		
		φD	A																
tol.		—	—	±0.05	±1.0	±0.2	±0.7	±1.0	+0.8 -0.2	±0.5	min.	±0.5	max.	±0.75	±0.5				
Nominal	TA	4	5	0.45	12.7	12.7	5.1	6.35	2.5	18.0	6.0	9.0	1.5	18.5	16.0		1		
	TC						3.85		5					17.5					
	TD		5.1	2.5	18.5														
	TC		3.85	5	17.5														
	TD	5	5 to 7	0.45	12.7	12.7	5.1	6.35	2.5	18.0	6.0	9.0	1.5	18.5	16.0		2		
	TC						3.85		5					17.5					
	TD	9 to 15	0.5	12.7	12.7	5.1	6.35	2.5	18.0	10.0	9.0	1.5	18.5	16.0				1	
	TC					3.85		5					17.5						
	TD	6.3	5 to 7	0.45	12.7	12.7	5.1	6.35	2.5	18.0	6.0	9.0	1.5	18.5		16.0			3
	TC						3.85		5					17.5					
	TD	9 to 15	0.5	12.7	12.7	5.1	6.35	2.5	18.0	10.0	9.0	1.5	18.5	16.0		1			
	TC					3.85		5					17.5						
TD	8	5	0.45	12.7	12.7	5.1	6.35	2.5	18.0	6.0	9.0	1.5	18.5	16.0				3	
TC						3.85		5					17.5						
TD	7	0.45	12.7	12.7	3.85	6.35	5	18.0	6.0	9.0	1.5	17.5	16.0		1				
TC																3.85			5
TD	9 to 20	0.6	12.7	12.7	3.85	6.35	3.5	18.0	10.0	9.0	1.5	20.0	16.0				1		
TC																		3.85	5
tol.		±0.5	max.	±0.05	±1.0	±0.3	±0.7	±1.3	+0.8 -0.2	±0.5	min.	±0.5	max.	+2.0 -0	—				
Nominal	TD	10	21	0.6	12.7	12.7	3.85	6.35	5	18.0	12.5	9.0	1.5	18.0	—				3
	TD	12.5	26	0.6	15	15	5.0	7.5	5	18.0	12.5	9.0	1.5	18.0	—		3		
	TE			0.6	25.4	12.7	3.85	6.35	5	18.0	12.5	9.0	1.5	18.0	—		4		

* 1 : For φ4×7 (A=7, F=25), shall be 18.5^{-0.5/+0.75} (Taping code : TD) at Fig.2.

* 2 : P=15 taping is not standard. Use P=25.4 taping.

TAPING CODE

Example

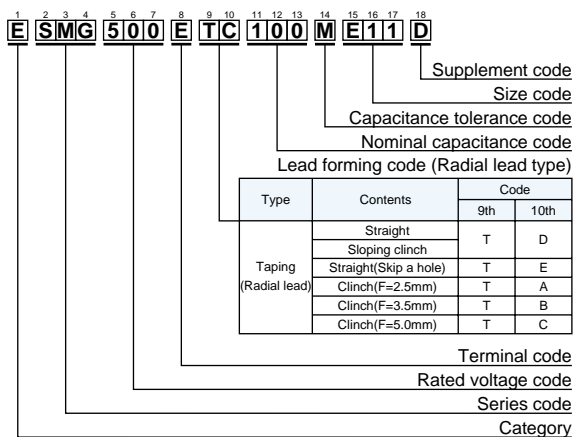

QUANTITY PER AMMO PACK

Ammo pack box

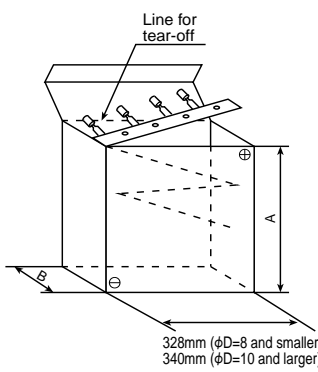

Typical example

Case size φD × L(mm)	A (mm)	B (mm)	Quantity (pcs.)
φ4	L=5 & 7mm	183	42
	L=11.5mm	183	51
φ5	L=5 & 7mm	232	42
	L=9 to 15mm	232	51
φ6.3	L=17mm	235	60
	L=5 & 7mm	282	42
φ8	L=9 to 15mm	284	51
	L=17 & 20mm	235	60
φ10	L≤16mm	308	56
	L=17 to 20mm	308	62
	L=21 to 25mm	308	67
	L=26 to 30mm	308	71
φ12.5	L≤16mm	308	62
	L=17 to 25mm	308	67

*Minimum order quantity for PSF/PSE/PSC/PSA/PS series

RADIAL LEAD TYPE (CUT/FORMED LEAD)

The following lead configurations are available. When ordering, please indicate the type of lead configurations by using the appropriate supplement code, such as C5, FC, MC or RC in the product part number.

[mm]

●Lead code : C5

$\phi D=4$ to 18

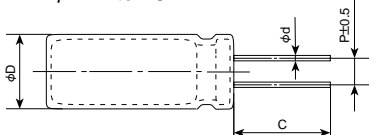

Case diameter C:Lead length

$\phi D=4$ to 8 : 5.0 ± 0.5

$\phi D=10$ to 18 : $5.0^{+1.0}_{-0}$

●Lead code : C3

$\phi D=4$ to 18

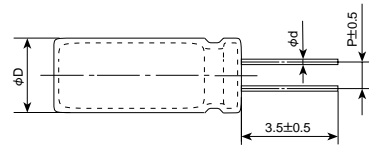

●Lead code : FC

$\phi D=5$ to 8

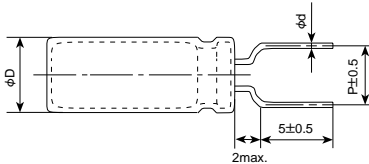

●Lead code : FM

$\phi D=5$ to 8

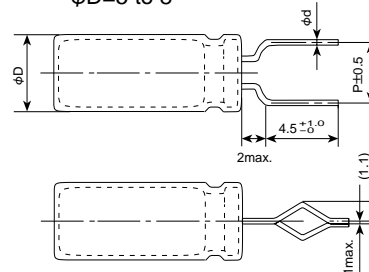

●Lead code : MC

$\phi D=10$ to 18

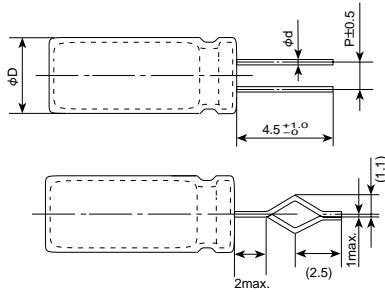

●Lead code : RC

$\phi D=20$ & 22

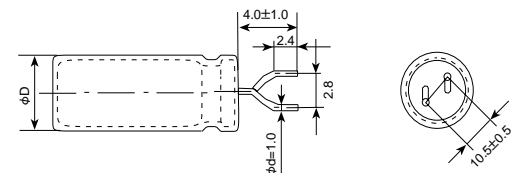

●Lead code : BC

$\phi D=10, 12.5$: $P=5.0 \pm 0.5$

$\phi D=14.5, 16, 18$: $P=7.5 \pm 0.5$

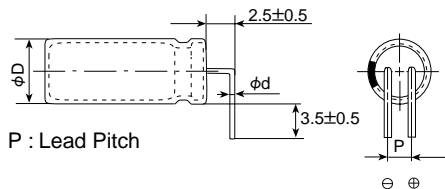



PACKAGING

MINIMUM ORDER QUANTITY

Please order by minimum order quantity.

◆SURFACE MOUNT

●Vertical



Series	Size code	Quantity (pcs)		
		Taping	Tray (pcs/box)	
Alchip™ MVS/MVA/MV MVE/MVK/MZA MVY/MZF/MZE MZD/MLA/MVJ MLF/MLE/MLD MVL/MVH/MHB MKB/MV-BP MVK-BP	B55	2,000	—	
	D46, D55, D60, D61	2,000	—	
	D73	1,500	—	
	E46, E55, E60, E61, E73	1,000	—	
	F45, F46, F55, F60, F61, F73	1,000	—	
	F80, H80	900	—	
	F90	800	—	
	H63, H70	1,000	—	
	HA0	500	—	
	HC0	400	—	
	J80, JA0	500	—	
	JC0	400	—	
	NPCAP™ PXS/PXF/PXE PXA/PXH	KE0	200	600
		KG5	150	600
		LH0	125	400
		LN0	75	400
MH0		125	300	
MN0	75	300		

◆RADIAL



Size	Quantity (pcs)	
	Bagged*1	Taping
φ4	200	2,000
φ5	200	2,000
φ6.3	200 (200)*2	2,000 (2,000)*2
φ8	200 (100)*2	1,000 (1,000)*2
φ10	Height ≤ 25mm	200 (100)*2
	Height ≥ 30mm	200
φ12.5	100	500
φ14.5	50	250
φ16	50	250
φ18	50	250

*1 Standard bagged quantity.

*2 Minimum order quantity for PSF/PSE/PSC/PSA/ PS series.

◆SNAP-IN

200 pieces



AVAILABLE TERMINALS FOR SNAP-IN TYPE [mm]

The following terminal options can be selected.

Please consult with us before purchase.

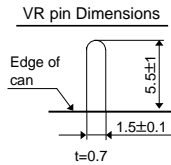
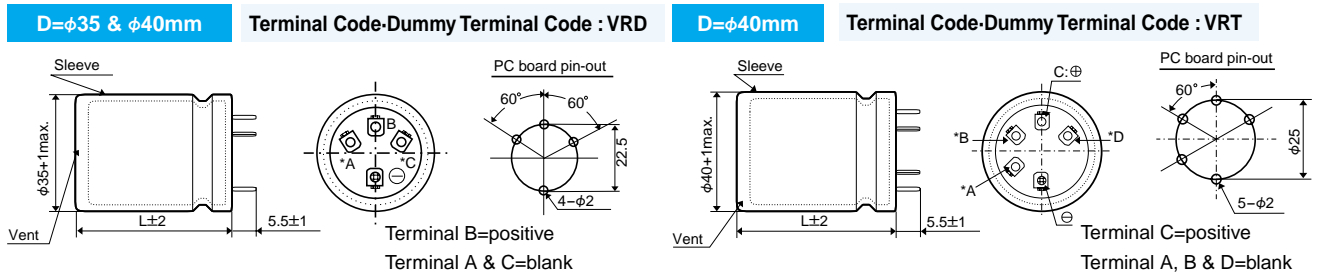
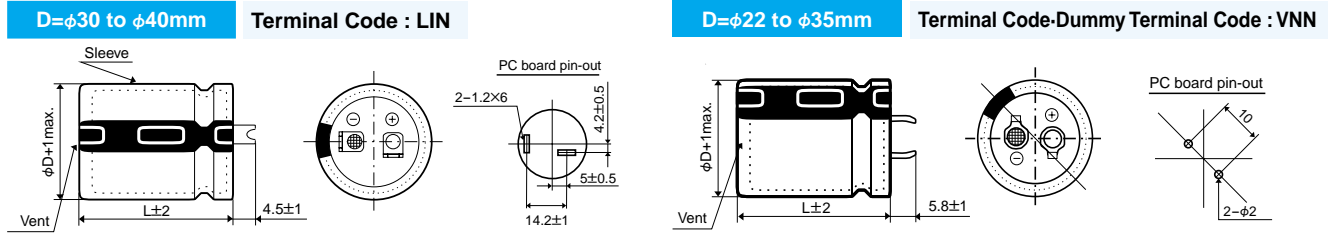

CAUTION

* Use the blank terminals for mechanical support only.
The blank terminals must not be connected to any copper trace on PC board.
Be sure to electrically isolate from the negative and the positive terminals.

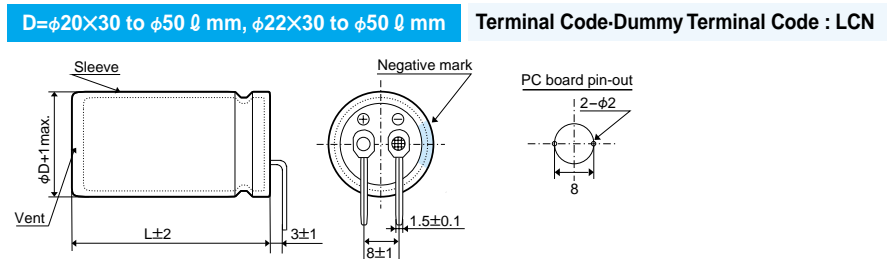

RECOMMENDED REFLOW SOLDERING CONDITIONS

NPCAP™-PXS/PXF/PXE/PXA/PXH Series

The following conditions are recommended for air or infrared reflow soldering PXS/PXF/PXE/PXA/PXH series onto a glass epoxy circuit board of 90×50×0.8mm (with resist) by cream solder. The temperatures shown are the surface temperature values on the top of the can and temperature of capacitor terminal.

Reflow should be performed twice or less.

Please ensure that the capacitor became cold enough to the room temperature (5 to 35°C) before the second reflow.

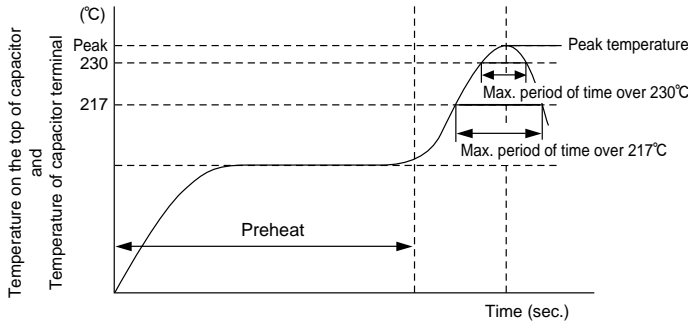

Voltage range (Vdc)	Preheat	Time maintained above 217°C	Time maintained above 230°C	Peak temp.	Reflow number
2.5 to 16V	150 to 180°C 120 sec.max.	50 sec.max.	40 sec.max.	260°Cmax.	1-cycle only
				250°Cmax.	2-cycle allowed
20 to 25V		50 sec.max. (40 sec.max.)	40 sec.max. (30 sec.max.)	250°Cmax.	1-cycle only
		40 sec.max.	30 sec.max.	(240°Cmax.)	2-cycle allowed

() : Applies for 20V 82μF(J80) and 25V 39μF(J80)

●Recommended Solder Land on PC Board

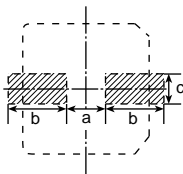

Solder land on PC board

Size code	a	b	c
D55	1.0	2.6	1.6
E60,E61	1.4	3.0	1.6
F45, F55, F60 F61, F80	1.9	3.5	1.6
H70, H80, HA0, HC0	3.1	4.2	2.2
J80, JA0, JC0	4.5	4.4	2.2

◆PRECAUTIONS FOR USERS

Soldering method

The capacitors of NPCAP™-PXS/PXF/PXE/PXA/PXH series have no capability to withstand such dip or wave soldering as totally immersing components into a solder bath.

Reflow soldering

Reflow the capacitors within Recommended Reflow Soldering Conditions. Verify there is no temperature stress to the capacitors because the following differences might degrade capacitors electrically and mechanically. Please consult with us if other reflow conditions are employed.

- 1.Location of components : Temperature increases at the edge of PC board more than the center.
- 2.Population of PC board : The lower the component population is, the more temperature rises.
- 3.Material of PC board : A ceramic-made board needs more heat than a glass epoxy-made board. The heat increase may cause damage to the capacitors.
- 4.Thickness of PC board : A thicker board needs more heat than a thinner board. The heat may damage the capacitors.
- 5.Size of PC board : A larger board needs more heat than a smaller board. The heat may damage the capacitors.
- 6.Solder thickness
If very thin cream solder paste is to be used for SMD types, please consult with us.
- 7.Location of infrared ray lamps : IR reflow as well as hot plate reflow heats only on the reverse side of the PC board to lessen heat stress to the capacitors.
- 8.Case leakage current will increase (~mA) after the reflow process, the leakage current which rose gradually decreases when voltage is applied.

Rework of soldering

Use a soldering iron for rework. Do not exceed an iron tip temperature of 380±10°C and an exposure time of 3±0.5 seconds.

Mechanical stress

Do not grab the capacitors to lift the PC board and give stress to the capacitor. Avoid bending the PC board. This may damage the capacitors.

Cleaning assembly board

Immediately after solvent cleaning, remove residual solvent with an air knife for at least 10 minutes. If the solvent is insufficiently dry, the capacitors may corrode.

Coating on assembly board

- 1.Before curing coating material, remove the cleaning solvents from the assembly board.
- 2.Before conformal coating, a chloride free pre-coat material is recommended to decrease the stress on the capacitors.

Molding with resin

Internal chemical reaction gradually produces gas in the capacitor; increasing internal pressure. If the end seal of the capacitor is completely covered by resin the gas will be unable to escape causing a potentially dangerous situation. The chlorine in resin will penetrate the end seal, reach the element, and damage of the capacitor.

Glue

The followings are requirements for glue.

- 1.A low curing temperature over a short period of time
- 2.Strong adhesion and heat resistance after curing
- 3.Long shelf life
- 4.No corrosion

Others

Refer to Precautions for Users of Aluminum Electrolytic Capacitors.

RECOMMENDED REFLOW SOLDERING CONDITIONS

Alchip™-MVS/MVA/MV/MVE/MVK/MZA/MVY/MZF/MZE/MZD/MLA/MVJ/MLF/MLE/MLD/MVL/MVH/MHB/MKB/MV-BP/MVK-BP

The following conditions are recommended for air convection and infrared reflow soldering on the SMD products on to a glass epoxy circuit boards by cream solder. The dimensions of the glass epoxy boards with resist are 90×90×0.8mm for B55 to KG5 case code SMD capacitors and 180×90×0.8mm for LH0 to MN0 case codes SMD capacitors.

The temperatures shown are the surface temperature values on the top of the can and on the capacitor terminals.

Reflow should be performed twice or less.

Please ensure that the capacitor became cold enough to the room temperature (5 to 35°C) before the second reflow.

Consult with us when performing reflow profile in IPC / JEDEC (J-STD-020)

●Recommended soldering heat conditions (Except for Conductive Polymer Aluminum Solid Capacitors)

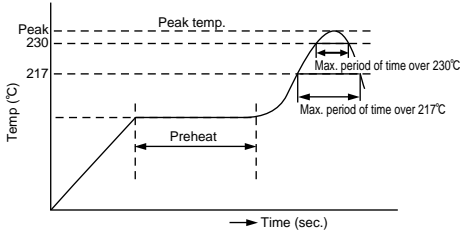

Contents			Lead-free type (high heat durability design)				Original type					
SMD type	Case code	Voltage range (Vdc)	Use Supplement Code "G" for case code B55 to JA0, and "S" for case code KE0 to MN0				Supplement Code "N"					
			Preheat	Time maintained above 217°C	Time maintained above 230°C	Peak temp.	Reflow number	Preheat	Time maintained above 200°C	Peak temp.		
Vertical	B55 to F90	4 to 50V 63 to 80V	150 to 180°C 120sec. max.	90sec. max.	60sec. max.	260°Cmax.	2 times or less	150°Cmax.	20sec. max.	240°Cmax.		
	H63 to JA0	4 to 50V		60sec. max.	40sec. max.	250°Cmax.				—		
		63 to 100, 400V		30sec. max.	30sec. max.	245°Cmax.				230°Cmax.		
	KE0 to MN0	6.3 to 50V		30sec. max.	20sec. max.	240°Cmax.				2 times or less	120sec. max.	230/240°Cmax.
		63 to 450V		20sec.	—	230°Cmax.				2 times or less		
D46, E46, F46	4 to 50V	40sec. max.	30sec. max.	250°Cmax.	2 times or less	—						

●Recommended Solder Land on PC Board

Series : MVS/MVA/MV/MVE/MVK/MZA/MVY/MZF/MZE/MZD/MLA
MVJ/MLF/MLE/MLD/MVL/MVH/MHB/MKB/MV-BP/MVK-BP

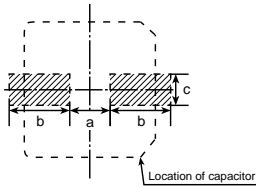

: Solder land on PC board

Case code	Terminal code : A			Terminal code : G		
	a	b	c	a	b	c
B55	0.8	2.2	1.6			
D46, D55, D60, D61, D73	1.0	2.6	1.6			
E46, E55, E60, E61, E73	1.4	3.0	1.6			
F46, F55, F60, F61, F73, F80, F90	1.9	3.5	1.6			
H63	2.3	4.5	1.6			
HA0	3.1	4.2	2.2			
JA0	4.5	4.4	2.2	4.5	4.4	3.5
KE0, KG5	4.0	5.7	2.5	3.4	6.3	9.3
LH0, LN0	6.0	6.9	2.5	4.7	7.8	9.6
MH0, MN0	6.0	7.9	2.5	4.7	8.8	9.6

◆PRECAUTIONS FOR USERS

Soldering method

The capacitors of Alchip-series have no capability to withstand such dip or wave soldering as totally immerses components into a solder bath.

Reflow soldering

Reflow the capacitors within recommended reflow soldering conditions. Verify there is no temperature stress to the capacitors because the following differences might degrade capacitors electrically and mechanically. Please consult us if other reflow conditions are employed.

1. Location of components : Temperature increases at the edge of PC board more than the center.
2. Population of PC board : The lower the component population is, the more temperature rises.
3. Material of PC board : A ceramic made board needs more heat than a glass epoxy made board. The heat increase may cause damage to the capacitors.
4. Thickness of PC board : A thicker board needs more heat than a thinner board. The heat increase may damage the capacitors.
5. Size of PC board : A larger board needs more heat than a smaller board. The heat increase may damage the capacitors.
6. Solder thickness
If very thin cream solder paste is to be used for SMD types, please consult with us.
7. Location of infrared ray lamps : IR reflow as well as hot plate reflow heats only on the reverse side of the PC board to lessen heat stress to the capacitors.

Rework of soldering

Use a soldering iron for rework. Do not exceed an iron tip temperature of 380±10°C and an exposure time of 3±0.5 seconds.

Mechanical stress

Do not use the capacitors for lifting the PC board and give stress to the capacitor. Avoid bending the PC board. This may damage the capacitors.

Cleaning assembly board

Immediately after solvent cleaning, remove residual solvent with an air knife for at least 10 minutes. If the solvent is insufficiently dry, the capacitors may corrode.

Coating on assembly board

1. Before curing coating material, remove the cleaning solvents from the assembly board.
2. Before conformal coating, a chloride free pre-coat material is recommended to decrease the stress on the capacitors.

Molding with resin

Internal chemical reaction gradually produces gas in the capacitor; then, increasing internal pressure. If the end seal of the capacitor is completely covered by resin the gas will be unable to escape causing a potentially dangerous situation. The chlorine contained resin will penetrate into the end seal, reach the inside element, and cause damage of the capacitor.

Others

Refer to Precautions for Users of Aluminum Electrolytic Capacitors.



STANDARDIZATION

The following series are discontinued. Please use the replacements in the table.

◆ CONDUCTIVE POLYMER REPLACEMENT(CHIP TYPE)

Discontinued series	Characteristics	Replacements
PX	105°C Super low ESR	PXA

◆ CHIP TYPE REPLACEMENTS

Discontinued series	Characteristics	Replacements
MKA	105°C Standard	MVK

◆ LEAD TYPE REPLACEMENTS



Discontinued series	Characteristics	Replacements	Discontinued series	Characteristics	Replacements	
SL	85°C standard	SMG	KX	High heat resistance	GXE	
SM						
SMC						
SME						
KM	105°C standard	KMG	EX			
KMC						
KME						
USM						
BSM	95°C L=7mm	LXY/LXZ	EU	High temperature performance	LXY	
SHA			150°C high heat resistance	*		
SM-BP	85°C bi-polar	SME-BP	GHA	Low leakage current	LLA/KY	
KM-BP	105°C bi-polar	KME-BP	LL		LLA	
SR	85°C low profile	SRG	KHA	High ripple current	KXG	
SRC						
SRJ						
SX			Low impedance	KY/LXV	KXB	
SXA	KMF(160 to 450Vdc)	JIS B-X characteristics			KMG	
SXC	BX	85°C large radial			SMG/SMH	
RX	SM(VP-type)	High operating temperature			*	
RXC	SRF					
LXE	GX-VH					
LXJ	SD					2 volt
SXE	SB					For memory backup
KMF(6.3 to 100Vdc)	KRL					105°C low leakage current
SXF	KSA	Bi-polar high ripple				
LXF	SRE(5.2L)	L=5.2mm				
TXF	FTK	Appropriate shape				
LXA	Long life	KY/ LXY				
LX(10 to 63Vdc)			*			

◆ SNAP-IN REPLACEMENTS



Discontinued series	Characteristics	Replacements
SM	85°C standard	SMH/SMM
SME		
SMG		
KM	105°C standard	KMH/KMM
KME		
KMG		
NM	Long case size	SMH
NMA		
BK	Long height	KMH/KMM
NM-HR	High ripple current	
BX	JIS B-X characteristics	
LX	Long life	LXG/LXQ
LXA		
KLH	Overvoltage resistant design	CHA
RZ		
GX	Low impedance	*
VD	voltage doubler rectifier circuit	

◆ SCREW-MOUNT TERMINAL REPLACEMENTS



Discontinued series	Characteristics	Replacements
EW	85°C standard	SME
PW		
MW		
GW		
SW	100°C	KMH
RW	For inverters	RWE/RWF
RWA		
KM	High reliability	KMH
KME		
LX	105°C Long life	LXA/LXR
LWY		
KW	Low impedance, Long life	*
FW	Low impedance	

* Please contact us.

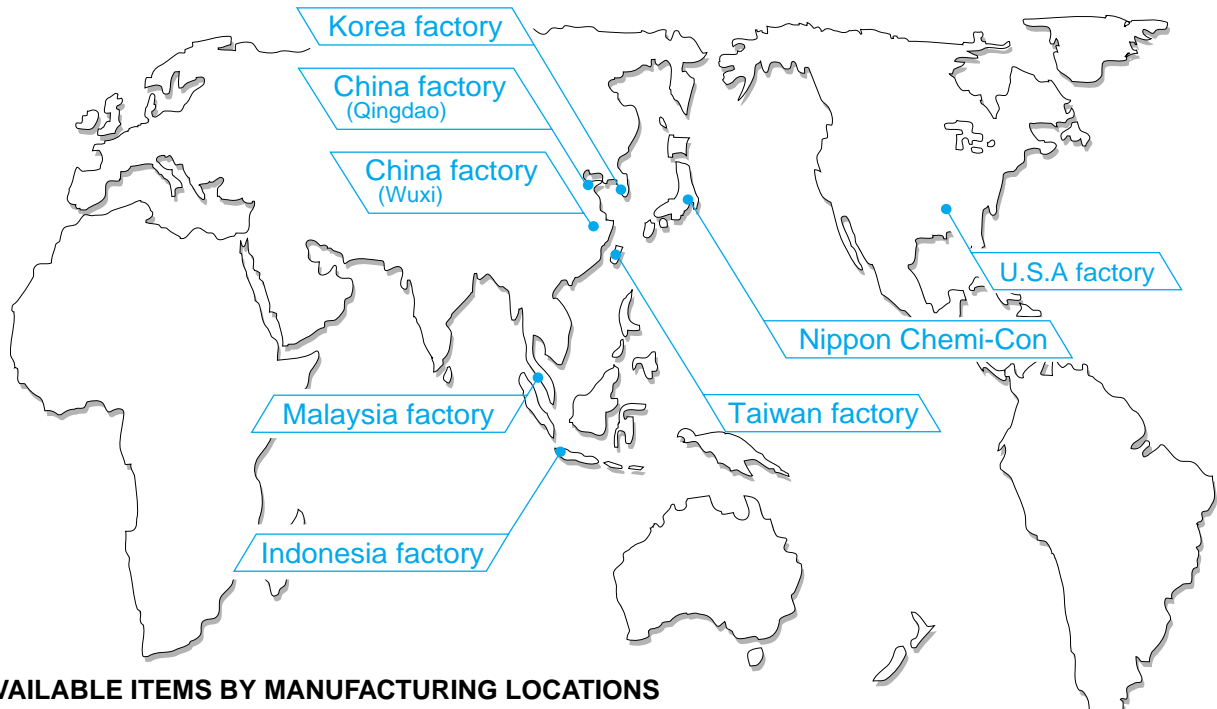

◆AVAILABLE ITEMS BY MANUFACTURING LOCATIONS

Classification	Series	Korea factory	China factory (Qingdao)	China factory (Wuxi)	Indonesia factory	Taiwan factory	Malaysia factory	U.S.A. factory
SMD	MV	●		●	●			
	MVK	●		●	●			
Low Profile	SRE				●			
	SRA		●		●			
	KMA		●		●			
	SRG		●		●			
General purpose	SMG	●	●	●	●	●		
	KMG	●	●	●	●	●		
	SMQ			●	●			
	KMQ			●	●			
Bi-polar	SME-BP	●	●		●	●		
	KME-BP	●	●		●	●		
Low impedance, High ripple	LXV			●	●	●		
	LXY			●	●			
	KY	●	●	●	●	●		
	KZE	●	●	●	●	●		
	KXG			●				
Snap-in	SMQ			●			●	
	KMQ			●			●	
	SMH			●			●	●
	KMH			●			●	●
	SMM			●			●	●
	KMM			●			●	●
Screw-mount Terminal	KMH							●
	RWE							●
	RWF							●
	RWL							●
	LXA							●

Please be sure to contact us before ordering as our product range is continuously improved and the product you require may have been superseded.

The NPCAP™ is a Conductive Polymer Solid Aluminum Capacitor that uses highly conductive polymer electrolytic material. Please read the following in order to get the most out of your NPCAP™ capacitor.
For aluminum electrolytic capacitors, please refer to PRECAUTIONS AND GUIDELINES.

Designing Device Circuits

1 Types of Circuits Where NPCAP™ Capacitors are Not to be Used

The leakage current in conductive polymer solid aluminum capacitors (hereafter called capacitors) may vary depending on thermal stresses during soldering. Avoid the use of capacitors in the following types of circuits:

- a) High-impedance circuits that are to sustain voltages.
- b) Coupling circuits
- c) Time constant circuits

Because the capacitance varies depending on the environment the capacitors are used in, there is a possibility that the capacitor can affect a time constant circuit where sensitivity to variation in capacitance is required.

- d) Other circuits that are significantly affected by leakage current

2 Circuit Design

Verify the following before designing the circuit:

- a) The electrical characteristics of the capacitor will vary depending on differences in temperature and frequency. Only design your after verifying the scope of these factors.
- b) When connecting two or more capacitors in parallel, ensure that the design takes current balancing into account.
- c) When two or more capacitors are connected in series, variability in applied voltage may cause over-voltage conditions. Contact Nippon Chemi-Con before using capacitors connected in series.
- d) Avoid putting heat generating parts either around the capacitor or on the reverse of the circuit board.

3 Use in High Reliable and Critical Applications

Consult with Nippon Chemi-Con before using these capacitors in applications involving human life: Aviation/space equipment, Nuclear power equipment, Medical equipment and Automotive equipment, or in applications where capacitor failure could have a major impact.

4 Polarity

The NPCAP™ is a polarized solid aluminum electrolytic capacitor. Do not apply either reverse voltages or AC voltages to the polarized capacitors, using reversed polarity may cause a short circuit. Refer to the catalog, product specifications or capacitor body to confirm the polarity prior to use.

5 Operating Voltage

Do not apply a greater than rated voltage, if a voltage greater than the rated voltage is suddenly applied the leakage current increases causing shorting. The peak voltage of superimposed AC voltages (ripple voltages) on DC voltages must not exceed the full rated voltage. While there are specifications for surge voltages exceeding the rated voltage, usage conditions apply, and continued operation for extended periods of time under such conditions cannot be guaranteed.

6 Ripple Current

Do not apply currents in excess of the rated ripple current. The superimposition of a large ripple current increases the rate of heating within the capacitor. When excessive ripple current is imposed the internal temperature increases which can shorten life and shorting may occur.

7 Operating Temperature

Use within the stated category temperature range, if used outside this range, characteristics can deteriorate potentially leading to problems.

8 Charging and Discharging the Capacitor

Do not use the NPCAP™ capacitor in circuits where the capacitor is repetitively charged and discharged rapidly. Repetitively charging and discharging the capacitor rapidly may reduce the capacitance or may cause damage due to internal heating. Use of a protective circuit to ensure reliability is recommended when rush currents exceed 20A.

9 Leakage current

Leakage current will increase, but it will gradually decrease if leakage current has been impressed at a temperature below the category's upper temperature limit. Additionally the self repairing action is faster when voltage near the rated voltage rather than at a higher voltage is applied at below the category's upper temperature limit. Generally the primary factors for leakage current rise are as follows:

- a) After soldering
- b) After testing as follow: High temperature exposure, high temperature and high humidity storage and temperature cycling etc.

10 Failures and Service Life

Based on the JIS C 5003 Standard, the failure rate for NPCAP™ capacitors (with a 60% reliability standard) is as follows:

0.5%/1,000 hours (applied rated voltage at category temperature)

a) Failure Modes

- (1) For failure mode, temperature is assumed to be the main reason for capacitance decrease and ESR increase leading to open mode end of life failure but over-voltage and over-current are assumed to be the short mode cause.
- (2) Reducing ambient temperature, ripple current, applied voltage reduces the failure rate and delays the time to failure.
- (3) If a voltage over the rated voltage is applied and perhaps a short occurs if after the short the electrical current is large, it does due to internal pressure increase and a strong smelling gas is given off.
- (4) The product contains flammable materials. If the short causes a spark it may ignite.

Please be careful when installing the product, its position and the layout design.

- Increase safety by using in conjunction with a protective circuit or protective equipment.
- Install measures such as redundant circuits so that the failure of a part of the equipment will not cause unstable operation.

b) Service Life

NPCAP™ uses rubber as the sealing material, so the service life depends on the thermal integrity of this rubber. Consequently, it is recommended to use the capacitor at a lower temperature than the maximum temperature for the capacitor category.

11 Capacitor Insulation

Insulation of the capacitor's case is not guaranteed. Ensure electrical insulation between the capacitor case, negative electrode, positive electrode and circuit pattern.

12 Capacitor Usage Environment

Do not use/expose capacitors to the following conditions.

- a) Oil, water, salty water, take care to avoid storage in damp locations.
- b) Direct sunlight

- c) Toxic gases such as hydrogen, sulfide, sulfurous acids, nitrous acids, chlorine and chlorine compounds, bromine and bromine compounds, ammonia, etc.
- d) Ozone, ultraviolet rays and radiation.
- e) Severe vibration or mechanical shock conditions beyond the limits advised in the product specification section of the catalog.

13 Capacitor mounting

- a) For the surface mount capacitor, design the copper pads on the PC board in accordance with the catalog or the product specification
- b) For radial capacitors, design the terminal holes on the PC board to fit the terminal pitch of the capacitor.

Installing Capacitors

1 Installing

- a) Do not reuse capacitors already assembled in equipment that have been exposed to power.
- b) The capacitor may have self charge. If this happens, discharge the capacitor through a resistor of approximately 1k Ω before use.
- c) If capacitors are stored at a temperature of 35°C or more and more than 75%RH, the leakage current may increase. This may also occur if the capacitors are stored for a longer period than the period which is specified in the catalog or the product specification. In this case, they can be reformed by the voltage treatment through a resistor of approximately 1k Ω .
- d) Verify the rated capacitance and voltage of the capacitors when installing.
- e) Verify the polarity of the capacitors.
- f) Do not use the capacitors if they have been dropped on the floor.
- g) Do not deform the case of the capacitors.
- h) Verify that the lead spacing of the capacitor fits the hole spacing in the PC board before installing the capacitors.
- i) Do not apply any mechanical force in excess of the limits prescribed in the catalog or the product specification of the capacitors. Avoid subjecting the capacitor to strong forces, as this may break the electrode terminals, bend or deform the capacitor, or damage the packaging, and may also cause short/open circuits, increased leakage current, or damage the appearance. Also, note the capacitors may be damaged by mechanical shocks caused by cut the lead wire, the vacuum/insertion head, component checker or centering operation of an automatic mounting or insertion machine.

2 Heat Resistance during Soldering

Ensure that the soldering conditions meet the specifications recommended by Nippon Chemi-Con. Note that the leakage current may increase or capacitance may decrease due to thermal stresses that occur during soldering, etc. Furthermore, the leakage current which rose gradually decreases, when voltage is applied at below the category upper limit temperature. Additionally the self repairing action is faster when voltage near the rated voltage rather than at a higher voltage is applied at below the category's upper temperature limit.

- a) Verify the following before using a soldering iron:
 - That the soldering conditions (temperature and time) are within the ranges specified in the catalog or product specifications.
 - That the tip of the soldering iron does not come into contact with the capacitor itself.
- b) Verify the following when flow soldering:
 - Do not dip the body of a capacitor into the solder bath only

dip the terminals in. The soldering must be done on the reverse side of PC board.

- Soldering conditions (preheat, solder temperature and dipping time) should be within the limits prescribed in the catalog or the product specifications.
- Do not apply flux to any part of capacitors other than their terminals.
- Make sure the capacitors do not come into contact with any other components while soldering.
- c) Verify the following when reflow soldering:
 - Soldering conditions (preheat, solder temperature and soldering time) should be within the limits prescribed in the catalogs or the product specification.
 - The heat level should be appropriate. (Note that the thermal stress on the capacitor varies depending on the type and position of the heater in the reflow oven, and the color and material of the capacitor.)
 - Vapor phase soldering (VPS) is not used.
 - Except for the surface mount type, reflow soldering must not be used for the capacitors.
- d) Do not reuse a capacitor that has already been soldered to PC board and then removed. When using a new capacitor in the same location, remove the flux, etc. first, and then use a soldering iron to solder on the new capacitor in accordance with the specifications.
- e) Confirm before running into soldering that the capacitors are for reflow soldering.

3 Handling After Soldering

Do not apply any mechanical stress to the capacitor after soldering onto the PC board.

- a) Do not lean or twist the body of the capacitor after soldering the capacitors onto the PC board.
- b) Do not use the capacitors for lifting or carrying the assembly board.
- c) Do not hit or poke the capacitor after soldering to PC board. When stacking the assembly board, be careful that other components do not touch the aluminum electrolytic capacitors.
- d) Do not drop the assembled board.

4 Cleaning PC boards

- a) Do not wash capacitors by using the following cleaning agents. Solvent resistant capacitors are only suitable for washing using the cleaning conditions prescribed in the catalog or the product specification. In particular, ultrasonic cleaning will accelerate damage to capacitors.

- Halogenated solvents; cause capacitors to fail due to corrosion.
- Alkali system solvents; corrode (dissolve) an aluminum case.
- Petroleum system solvents; cause the rubber seal material to deteriorate.
- Xylene; causes the rubber seal material to deteriorate.
- Acetone; erases the markings.

CFC alternatives or the other cleaners above; please consult with us

- b) Verify the following points when washing capacitors.
 - Monitor conductivity, pH, specific gravity and the water content of cleaning agents. Contamination adversely affects these characteristics.
 - Be sure not to expose the capacitors under solvent rich conditions or keep capacitors inside a closed container. In addition, please dry the solvent sufficiently on the PC board and the capacitor with an air knife (temperature should be less than the maximum rated category temperature of the capacitor) for 10 minutes. Aluminum electrolytic capacitors can be characteristically and catastrophically damaged by halogen ions, particularly by chlorine ions, though the degree of the damage mainly depends upon



PRECAUTIONS AND GUIDELINES (Conductive Polymer)

the characteristics of the electrolyte and rubber seal material. When halogen ions come into contact with the capacitors, the foil corrodes when a voltage is applied. This corrosion causes an extremely high leakage current which results venting and an open circuit.

If the new types of cleaning agents mentioned below are used, the following are recommended as cleaning conditions for some of new cleaning agents.

-Higher alcohol cleaning agents

Pine Alpha ST-100S (Arakawa Chemical)
Clean Through 750 H, 750K, 750L, and 710M (Kao)
Technocare FRW-14 through 17 (Toshiba)
Cleaning Conditions:

Using these cleaning agents, capacitors are capable of withstanding immersion or ultrasonic cleaning for 10 minutes at a maximum liquid temperature of 60°C. Find optimum condition for washing, rinsing, and drying. Be sure not to rub the marking off the capacitor which can be caused by contact with other components or the PC board. Note that shower cleaning adversely affects the markings on the sleeve.

-Non-Halogenated Solvent Cleaning

AK225AES (Asahi Glass)
Cleaning Conditions:

Ultrasonic or vapor cleaning for 5 minutes. However, from an environmental point of view, these types of solvent will be banned in near future. We would recommend not using them if at all possible.

-Isopropyl Alcohol (IPA)

IPA (Isopropyl Alcohol) is one of the most acceptable cleaning agents; it is necessary to maintain a flux content in the cleaning liquid at a maximum limit of 2 Wt.%.

5 Precautions for using adhesives and coating materials

- a) Do not use any adhesive and coating materials containing halogenated solvent.
- b) Verify the following before using adhesive and coating material.
 - Remove flux and dust left over between the rubber seal and the PC board before applying adhesive or coating materials to the capacitor.
 - Dry and remove any residual cleaning agents before applying adhesive and coating materials to the capacitors. Do not cover over the whole surface of the rubber seal with the adhesive or coating materials.
 - For permissible heat conditions for curing adhesives or coating materials, follow the instructions in the catalog or the product specification for the capacitors.
 - Covering over the whole surface of the capacitor rubber seal with resin may result in a hazardous condition because the inside pressure cannot be completely released. Also, a large amount of halogen ions in resins will cause the capacitors to fail because the halogen ions penetrate into the rubber seal and the inside of the capacitor.
 - Consider that some solvents in the adhesives and coating materials may make the capacitor surface matt or result in whitening.

6 Fumigation

In many cases when exporting or importing electronic devices, such as capacitors, wooden packaging is used. In order to control insects it may become necessary to fumigate the shipment. Precautions during "Fumigation" using halogenated chemical such as Methyl Bromide must be taken. Halogen gas can penetrate packaging materials such as cardboard boxes and vinyl bags. Penetration of the halogenated gas can cause corrosion of Electrolytic capacitors. Nippon Chemi-Con gives consideration to the packaging materials not to require the Fumigation.

Verify whether the assembled PC board, products and capacitors themselves are subjected to Fumigation during their transportation or not.

The Operation of Devices

- a) Do not touch the capacitor terminals directly.
- b) Do not short-circuit the terminal of a capacitor by letting it come into contact with any conductive object. Also, do not spill electric-conductive liquid such as acid or alkaline solution over the capacitor.
- c) Do not use capacitors in circumstances where they would be subject to exposure to the following materials
 - Oil, water, salty water or damp location.
 - Direct sunlight.
 - Toxic gases such as hydrogen sulfide, sulfurous acid, nitrous acid, chlorine or its compounds, and ammonium.
 - Ozone, ultraviolet rays or radiation.
 - Severe vibration or mechanical shock conditions beyond the limits prescribed in the catalog or product specification.

Maintenance Inspection

- a) Make periodic inspections of capacitors that have been used in industrial applications. Before inspection, turn off the power supply and carefully discharge the electricity in the capacitors. Verify the polarity when measuring the capacitors with a volt-ohm meter. Do not apply any mechanical stress to the terminals of the capacitors.
- b) The following items should be checked during the periodic inspections.
 - Significant damage in appearance
 - Electrical characteristics: leakage current, capacitance, tanδ and other characteristics prescribed in the catalog or product specification.
 - We recommend replacing the capacitors if the parts are out of specification.

Contingencies

- a) If gas has vented from the capacitor during use, there is a short circuit and burning, or the capacitor discharges an odor or smoke, turn off the main power supply to the equipment or unplug the power cord.
- b) If there is a problem with the capacitor or a fire breaks out, the capacitor may produce a burning gas or reactive gas from the outer resin, etc. If this happens, keep your hands and face away from the gas. If vented gas is inhaled or comes into contact with your eyes, flush your eyes immediately with water and/or gargle. If vented gas comes into contact with the skin, wash the affected area thoroughly with soap and water.

Storage

We recommend the following conditions for storage.
a) Store capacitors in a cool, dry place. Store at a temperature between 5 and 35°C, with a humidity of 75% or less.

(table-1)

	Before the bag is opened	After the bag is opened
SMD	Within 3 years after manufacturing	Within 6 months after the bag is opened
Radial	Within 3 years after manufacturing	—

SMD products are sealed in a special laminated aluminum bag. Use all capacitors once the bag is opened. Return unused capacitors to the bag, and seal it with a zipper. Please refer to (Table -1) for storage conditions. Be sure to follow our recommendations for reflow soldering.

- b) Store the capacitors in a location free from direct contact



PRECAUTIONS AND GUIDELINES (Conductive Polymer)

with water, salt water, and oil.

- c) Store in a location where the capacitor is not exposed to toxic gas, such as hydrogen sulfide, sulfurous acid, nitrous acid, chlorine or chlorine compounds, bromine or other halogen gases, methyl bromide or other halogen compounds, ammonia, or similar.
- d) Store in a location where the capacitor is not exposed to ozone, ultraviolet radiation, or other radiation.
- e) It is recommended to store capacitors in their original packaging wherever possible.
- f) The JEDEC J-STD-020 (Rev. C) standard does not apply.

Disposal

Please consult with a local industrial waste disposal specialist when disposing of aluminum electrolytic capacitors.

Catalogs

Specifications in the catalogs may be subject to change without notice. For more details of precautions and guidelines for aluminum electrolytic capacitors, please refer to Engineering Bulletin No. 634A.



PART NUMBERING SYSTEM

Product code guide (Conductive polymer)

(Example : PXA series, 4V-150 μ F, ϕ 6.3 \times 5.7L)

Please refer to the following table

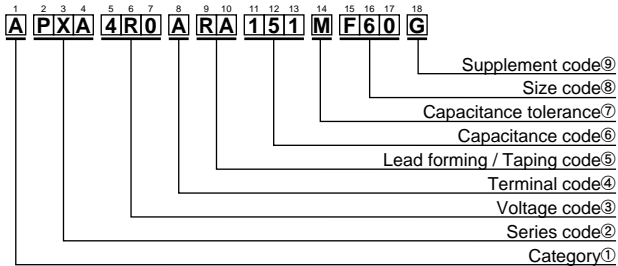

①Category

Contents	Code 1st
Polar	A

②Series code

Series name	Code		
	2nd	3rd	4th
PXA	P	X	A
PS	P	S	—

③Voltage code

Voltage (V)	Code		
	5th	6th	7th
2.5	2	R	5
4	4	R	0
6.3	6	R	3
10	1	0	0
16	1	6	0
20	2	0	0
25	2	5	0
35	3	5	0

④Terminal code

Type	Code 8th
SMD	A
Radial lead	E

⑤Lead forming code (Radial lead type)

Type	Contents	Code	
		9th	10th
Lead forming (Radial lead /Bulk)	Straight	L	L
	CC(3.5mm)	C	3
	CC(5.0mm)	C	5
Taping (Radial lead)	Straight	T	D

⑤Taping code (SMD)

Type	Taping contents	Reel dia. (mm)	Code		Application size ϕ D (mm)
			9th	10th	
Taping (SMD)	Reel for reuse	380	R	A	ϕ D=4 to 10
	Reel for reuse	330	R	B	ϕ D=8 to 10

Refer to product guide for taping specifications.

⑥Capacitance code

Cap. (μ F)	Code		
	11th	12th	13th
10	1	0	0
22	2	2	0
27	2	7	0
33	3	3	0
39	3	9	0
47	4	7	0
56	5	6	0
68	6	8	0
82	8	2	0
100	1	0	1
120	1	2	1
150	1	5	1
180	1	8	1
220	2	2	1
270	2	7	1
330	3	3	1
390	3	9	1
470	4	7	1
560	5	6	1
680	6	8	1
820	8	2	1
1,000	1	0	2
1,200	1	2	2
1,500	1	5	2

⑦Capacitance tolerance

Tol. (%)	Code 14th
\pm 20	M

⑧Size code (Radial lead type)

ϕ D	Code 15th
	6.3
8	H
10	J

L	Code	
	16th	17th
6	0	6
8	0	8
10.5	A	5
11.5	B	5
12.5	C	5

⑧Size code (SMD)

ϕ D	Code 15th
	5
6.3	F
8	H
10	J

L	Code	
	16th	17th
5.2	5	5
5.7	6	0
6.7	7	0
7.7	8	0
10	A	0
12	C	0
12.2	C	0

⑨Supplement code

Classification	Code 18th
Type	
SMD	G
Radial lead	S

* Refer to the appendix (Part number) for codes not listed here.

New!

NPCAP™-PXS Series

- Super low ESR, high ripple current capability
- Longer life (5,000 hours at 105°C)
- Rated voltage range : 4 to 16V_{dc}, Capacitance : 22 to 560μF
- Case size : φ5×5.8L to φ8×6.7L
- Suitable for DC-DC converters, voltage regulators and decoupling applications for computer motherboards etc.
- RoHS Compliant

PXS

↑ Longer life
PXA/PXE



◆ SPECIFICATIONS

Items	Characteristics										
Category											
Temperature Range	-55 to +105°C										
Rated Voltage Range	4 to 16V _{dc}										
Capacitance Tolerance	±20% (M) (at 20°C, 120Hz)										
Surge Voltage	Rated voltage×1.15 (at 105°C)										
Leakage Current	I=0.2CV Where, I : Max. leakage current (μA), C : Nominal capacitance (μF), V : Rated voltage (V _{dc}) (at 20°C after 2 minutes)										
Dissipation Factor (tanδ)	0.12 max. (at 20°C, 120Hz)										
Low Temperature Characteristics (Max. Impedance Ratio)	Z(-25°C)/Z(+20°C) ≤ 1.15 Z(-55°C)/Z(+20°C) ≤ 1.25 (at 100kHz)										
Endurance	The following specifications shall be satisfied when the capacitors are restored to 20°C after the rated voltage is applied for 5,000 hours at 105°C.										
	<table border="1"> <tr><td>Appearance</td><td>No significant damage</td></tr> <tr><td>Capacitance change</td><td>≤ ±20% of the initial value</td></tr> <tr><td>DF (tanδ)</td><td>≤ 150% of the initial specified value</td></tr> <tr><td>ESR</td><td>≤ 150% of the initial specified value</td></tr> <tr><td>Leakage current</td><td>≤ The initial specified value</td></tr> </table>	Appearance	No significant damage	Capacitance change	≤ ±20% of the initial value	DF (tanδ)	≤ 150% of the initial specified value	ESR	≤ 150% of the initial specified value	Leakage current	≤ The initial specified value
Appearance	No significant damage										
Capacitance change	≤ ±20% of the initial value										
DF (tanδ)	≤ 150% of the initial specified value										
ESR	≤ 150% of the initial specified value										
Leakage current	≤ The initial specified value										
Bias Humidity	The following specifications shall be satisfied when the capacitors are restored to 20°C after subjecting them to the DC rated voltage at 60°C, 90 to 95% RH for 1,000 hours.										
	<table border="1"> <tr><td>Appearance</td><td>No significant damage</td></tr> <tr><td>Capacitance change</td><td>≤ ±20% of the initial value</td></tr> <tr><td>DF (tanδ)</td><td>≤ 150% of the initial specified value</td></tr> <tr><td>ESR</td><td>≤ 150% of the initial specified value</td></tr> <tr><td>Leakage current</td><td>≤ The initial specified value</td></tr> </table>	Appearance	No significant damage	Capacitance change	≤ ±20% of the initial value	DF (tanδ)	≤ 150% of the initial specified value	ESR	≤ 150% of the initial specified value	Leakage current	≤ The initial specified value
Appearance	No significant damage										
Capacitance change	≤ ±20% of the initial value										
DF (tanδ)	≤ 150% of the initial specified value										
ESR	≤ 150% of the initial specified value										
Leakage current	≤ The initial specified value										
Surge Voltage	The capacitors shall be subjected to 1,000 cycles each consisting of charge with the surge voltage specified at 105°C for 30 seconds through a protective resistor(R=1kΩ) and discharge for 5 minutes 30 seconds.										
	<table border="1"> <tr><td>Appearance</td><td>No significant damage</td></tr> <tr><td>Capacitance change</td><td>≤ ±20% of the initial value</td></tr> <tr><td>DF (tanδ)</td><td>≤ 150% of the initial specified value</td></tr> <tr><td>ESR</td><td>≤ 150% of the initial specified value</td></tr> <tr><td>Leakage current</td><td>≤ The initial specified value</td></tr> </table>	Appearance	No significant damage	Capacitance change	≤ ±20% of the initial value	DF (tanδ)	≤ 150% of the initial specified value	ESR	≤ 150% of the initial specified value	Leakage current	≤ The initial specified value
Appearance	No significant damage										
Capacitance change	≤ ±20% of the initial value										
DF (tanδ)	≤ 150% of the initial specified value										
ESR	≤ 150% of the initial specified value										
Leakage current	≤ The initial specified value										
Failure Rate	0.5% per 1,000 hours maximum (Confidence level 60% at 105°C)										

*Note : If any doubt arises, measure the leakage current after the following voltage treatment.
Voltage treatment : DC rated voltage is applied to the capacitors for 120 minutes at 105°C.

◆ DIMENSIONS [mm]

● Terminal Code : A

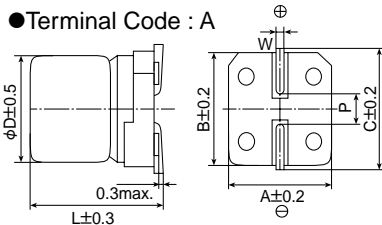

Size Code	φD	L	A	B	C	W	P
E61	5.0	5.8	5.3	5.3	5.9	0.5 to 0.8	1.4
F61	6.3	5.8	6.6	6.6	7.2	0.5 to 0.8	1.9
H70	8.0	6.7	8.3	8.3	9.0	0.7 to 1.1	3.1

◆ MARKING

EX) 6.3V390μF



◆ PART NUMBERING SYSTEM

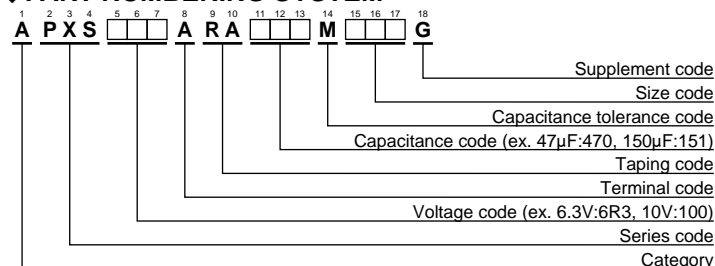

Please refer to "Product code guide (conductive polymer type)"



◆STANDARD RATINGS

WV (Vdc)	Cap (μF)	Size code	ESR (mΩmax/20°C, 100k to 300kHz)	Rated ripple current (mA _{rms} /105°C, 100kHz)	Part No.
4	150	E61	25	2,150	APXS4R0ARA151ME61G
	560	H70	22	3,220	APXS4R0ARA561MH70G
6.3	47	E61	30	1,970	APXS6R3ARA470ME61G
	100	E61	25	2,150	APXS6R3ARA101ME61G
	120	F61	22	2,570	APXS6R3ARA121MF61G
	220	F61	22	2,570	APXS6R3ARA221MF61G
	390	H70	22	3,220	APXS6R3ARA391MH70G
10	33	E61	70	1,100	APXS100ARA330ME61G
	68	E61	30	1,970	APXS100ARA680ME61G
	120	F61	27	2,320	APXS100ARA121MF61G
	150	H70	30	2,760	APXS100ARA151MH70G
16	22	E61	90	1,060	APXS160ARA220ME61G
	39	E61	35	1,820	APXS160ARA390ME61G
	39	F61	37	2,050	APXS160ARA390MF61G
	68	F61	30	2,200	APXS160ARA680MF61G
	82	H70	30	2,760	APXS160ARA820MH70G
	120	H70	27	2,900	APXS160ARA121MH70G

NPCAP™-PXF Series

- Super low ESR, impedance and high heat resistance have been obtained by using conductive polymer as electrolyte.
- Rated voltage range : 2.5 to 6.3V_{dc}, Capacitance range : 220 to 1,000μF
- Case size range : φ6.3×5.8L to φ8×7.7L
- Suitable for DC-DC converters, voltage regulators and decoupling applications used on computer motherboards etc.
- RoHS Compliant

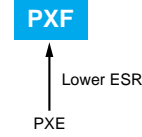

◆ SPECIFICATIONS

Items	Characteristics										
Category											
Temperature Range	-55 to +105°C										
Rated Voltage Range	2.5 to 6.3V _{dc}										
Capacitance Tolerance	±20% (M) (at 20°C, 120Hz)										
Surge Voltage	Rated voltage×1.15 (at 105°C)										
Leakage Current	I=0.3CV Where, I : Max. leakage current (μA), C : Nominal capacitance (μF), V : Rated voltage (V _{dc}) (at 20°C after 2 minutes)										
Dissipation Factor (tanδ)	0.12 max. (at 20°C, 120Hz)										
Low Temperature Characteristics (Max. Impedance Ratio)	Z(-25°C)/Z(+20°C) ≤ 1.15 Z(-55°C)/Z(+20°C) ≤ 1.25 (at 100kHz)										
Endurance	The following specifications shall be satisfied when the capacitors are restored to 20°C after the rated voltage is applied for 2,000 hours at 105°C.										
	<table border="1"> <tr><td>Appearance</td><td>No significant damage</td></tr> <tr><td>Capacitance change</td><td>≤ ±20% of the initial value</td></tr> <tr><td>DF (tanδ)</td><td>≤ 150% of the initial specified value</td></tr> <tr><td>ESR</td><td>≤ 150% of the initial specified value</td></tr> <tr><td>Leakage current</td><td>≤ The initial specified value</td></tr> </table>	Appearance	No significant damage	Capacitance change	≤ ±20% of the initial value	DF (tanδ)	≤ 150% of the initial specified value	ESR	≤ 150% of the initial specified value	Leakage current	≤ The initial specified value
Appearance	No significant damage										
Capacitance change	≤ ±20% of the initial value										
DF (tanδ)	≤ 150% of the initial specified value										
ESR	≤ 150% of the initial specified value										
Leakage current	≤ The initial specified value										
Bias Humidity	The following specifications shall be satisfied when the capacitors are restored to 20°C after subjecting them to the DC rated voltage at 60°C, 90 to 95% RH for 1,000 hours.										
	<table border="1"> <tr><td>Appearance</td><td>No significant damage</td></tr> <tr><td>Capacitance change</td><td>≤ ±20% of the initial value</td></tr> <tr><td>DF (tanδ)</td><td>≤ 150% of the initial specified value</td></tr> <tr><td>ESR</td><td>≤ 150% of the initial specified value</td></tr> <tr><td>Leakage current</td><td>≤ The initial specified value</td></tr> </table>	Appearance	No significant damage	Capacitance change	≤ ±20% of the initial value	DF (tanδ)	≤ 150% of the initial specified value	ESR	≤ 150% of the initial specified value	Leakage current	≤ The initial specified value
Appearance	No significant damage										
Capacitance change	≤ ±20% of the initial value										
DF (tanδ)	≤ 150% of the initial specified value										
ESR	≤ 150% of the initial specified value										
Leakage current	≤ The initial specified value										
Surge Voltage	The capacitors shall be subjected to 1,000 cycles each consisting of charge with the surge voltage specified at 105°C for 30 seconds through a protective resistor(R=1kΩ) and discharge for 5 minutes 30 seconds.										
	<table border="1"> <tr><td>Appearance</td><td>No significant damage</td></tr> <tr><td>Capacitance change</td><td>≤ ±20% of the initial value</td></tr> <tr><td>DF (tanδ)</td><td>≤ 150% of the initial specified value</td></tr> <tr><td>ESR</td><td>≤ 150% of the initial specified value</td></tr> <tr><td>Leakage current</td><td>≤ The initial specified value</td></tr> </table>	Appearance	No significant damage	Capacitance change	≤ ±20% of the initial value	DF (tanδ)	≤ 150% of the initial specified value	ESR	≤ 150% of the initial specified value	Leakage current	≤ The initial specified value
Appearance	No significant damage										
Capacitance change	≤ ±20% of the initial value										
DF (tanδ)	≤ 150% of the initial specified value										
ESR	≤ 150% of the initial specified value										
Leakage current	≤ The initial specified value										
Failure Rate	0.5% per 1,000 hours maximum (Confidence level 60% at 105°C)										

*Note : If any doubt arises, measure the leakage current after the following voltage treatment.
Voltage treatment : DC rated voltage is applied to the capacitors for 120 minutes at 105°C.

◆ DIMENSIONS [mm]

- Terminal Code : A

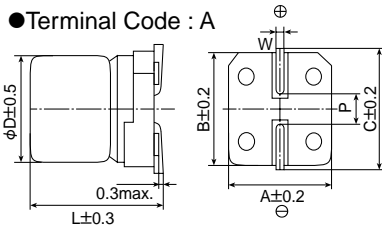

Size Code	φD	L	A	B	C	W	P
F61	6.3	5.8	6.6	6.6	7.2	0.5 to 0.8	1.9
F80	6.3	7.7	6.6	6.6	7.2	0.5 to 0.8	1.9
H70	8	6.7	8.3	8.3	9.0	0.7 to 1.1	3.1
H80	8	7.7	8.3	8.3	9.0	0.7 to 1.1	3.1

◆ MARKING

EX) 2.5V390μF

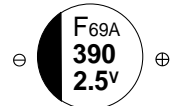

◆ PART NUMBERING SYSTEM

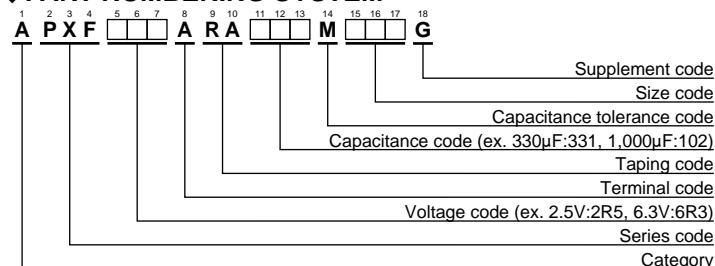

Please refer to "Product code guide (conductive polymer type)"



◆STANDARD RATINGS

WV (Vdc)	Cap (μF)	Size code	ESR (mΩmax/20°C, 100k to 300kHz)	Rated ripple current (mA _{rms} /105°C, 100kHz)	Part No.
2.5	390	F61	10	3,900	APXF2R5ARA391MF61G
	470	F80	9	4,200	APXF2R5ARA471MF80G
	560	F80	9	4,200	APXF2R5ARA561MF80G
	560	H70	9	4,500	APXF2R5ARA561MH70G
	680	H70	9	4,500	APXF2R5ARA681MH70G
	1,000	H80	9	4,500	APXF2R5ARA102MH80G
4	330	F61	10	3,900	APXF4R0ARA331MF61G
	390	F80	9	4,200	APXF4R0ARA391MF80G
	470	H70	9	4,500	APXF4R0ARA471MH70G
	560	H70	9	4,500	APXF4R0ARA561MH70G
	680	H80	9	4,500	APXF4R0ARA681MH80G
6.3	220	F61	10	3,900	APXF6R3ARA221MF61G
	270	F80	9	4,200	APXF6R3ARA271MF80G
	330	F80	9	4,200	APXF6R3ARA331MF80G
	330	H70	9	4,500	APXF6R3ARA331MH70G
	390	H70	9	4,500	APXF6R3ARA391MH70G
	470	H80	9	4,500	APXF6R3ARA471MH80G
	560	H80	9	4,500	APXF6R3ARA561MH80G

Upgrade!

NPCAP™-PXE Series

- Super low ESR, impedance and high heat resistance have been obtained by using conductive polymer as electrolyte. (ESR and rated ripple current values are improved from PXA series.)
- Rated voltage range : 2.5 to 16V_{dc}, Capacitance range : 33 to 2,700μF
- Case size range : φ5×5.8L to φ10×12.2L
- Suitable for DC-DC converters, voltage regulators and decoupling applications used on computer motherboards etc.
- RoHS Compliant

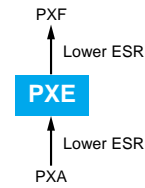

◆ SPECIFICATIONS

Items	Characteristics										
Category											
Temperature Range	-55 to +105°C										
Rated Voltage Range	2.5 to 16V _{dc}										
Capacitance Tolerance	±20% (M) (at 20°C, 120Hz)										
Surge Voltage	Rated voltage×1.15 (at 105°C)										
Leakage Current	Shall not exceed values shown in STANDARD RATINGS. (at 20°C after 2 minutes)										
Dissipation Factor (tanδ)	0.12 max. (at 20°C, 120Hz)										
Low Temperature Characteristics (Max. Impedance Ratio)	Z(-25°C)/Z(+20°C) ≤ 1.15 Z(-55°C)/Z(+20°C) ≤ 1.25 (at 100kHz)										
Endurance	The following specifications shall be satisfied when the capacitors are restored to 20°C after the rated voltage is applied for 2,000 hours at 105°C.										
	<table border="1"> <tr><td>Appearance</td><td>No significant damage</td></tr> <tr><td>Capacitance change</td><td>≤ ±20% of the initial value</td></tr> <tr><td>DF (tanδ)</td><td>≤ 150% of the initial specified value</td></tr> <tr><td>ESR</td><td>≤ 150% of the initial specified value</td></tr> <tr><td>Leakage current</td><td>≤ The initial specified value</td></tr> </table>	Appearance	No significant damage	Capacitance change	≤ ±20% of the initial value	DF (tanδ)	≤ 150% of the initial specified value	ESR	≤ 150% of the initial specified value	Leakage current	≤ The initial specified value
Appearance	No significant damage										
Capacitance change	≤ ±20% of the initial value										
DF (tanδ)	≤ 150% of the initial specified value										
ESR	≤ 150% of the initial specified value										
Leakage current	≤ The initial specified value										
Bias Humidity	The following specifications shall be satisfied when the capacitors are restored to 20°C after subjecting them to the DC rated voltage at 60°C, 90 to 95% RH for 1,000 hours.										
	<table border="1"> <tr><td>Appearance</td><td>No significant damage</td></tr> <tr><td>Capacitance change</td><td>≤ ±20% of the initial value</td></tr> <tr><td>DF (tanδ)</td><td>≤ 150% of the initial specified value</td></tr> <tr><td>ESR</td><td>≤ 150% of the initial specified value</td></tr> <tr><td>Leakage current</td><td>≤ The initial specified value</td></tr> </table>	Appearance	No significant damage	Capacitance change	≤ ±20% of the initial value	DF (tanδ)	≤ 150% of the initial specified value	ESR	≤ 150% of the initial specified value	Leakage current	≤ The initial specified value
Appearance	No significant damage										
Capacitance change	≤ ±20% of the initial value										
DF (tanδ)	≤ 150% of the initial specified value										
ESR	≤ 150% of the initial specified value										
Leakage current	≤ The initial specified value										
Surge Voltage	The capacitors shall be subjected to 1,000 cycles each consisting of charge with the surge voltage specified at 105°C for 30 seconds through a protective resistor (R=1kΩ) and discharge for 5 minutes 30 seconds.										
	<table border="1"> <tr><td>Appearance</td><td>No significant damage</td></tr> <tr><td>Capacitance change</td><td>≤ ±20% of the initial value</td></tr> <tr><td>DF (tanδ)</td><td>≤ 150% of the initial specified value</td></tr> <tr><td>ESR</td><td>≤ 150% of the initial specified value</td></tr> <tr><td>Leakage current</td><td>≤ The initial specified value</td></tr> </table>	Appearance	No significant damage	Capacitance change	≤ ±20% of the initial value	DF (tanδ)	≤ 150% of the initial specified value	ESR	≤ 150% of the initial specified value	Leakage current	≤ The initial specified value
Appearance	No significant damage										
Capacitance change	≤ ±20% of the initial value										
DF (tanδ)	≤ 150% of the initial specified value										
ESR	≤ 150% of the initial specified value										
Leakage current	≤ The initial specified value										
Failure Rate	0.5% per 1,000 hours maximum (Confidence level 60% at 105°C)										

*Note : If any doubt arises, measure the leakage current after the following voltage treatment.
Voltage treatment : DC rated voltage is applied to the capacitors for 120 minutes at 105°C.

◆ DIMENSIONS [mm]

● Terminal Code : A

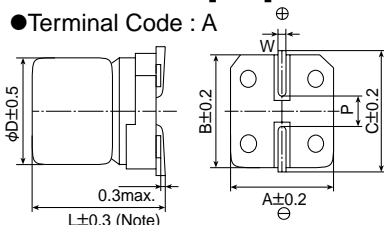

(Note) L±0.5 for HA0, HC0, JA0, JC0

Size Code	φD	L	A	B	C	W	P
E61	5	5.8	5.3	5.3	5.9	0.5 to 0.8	1.4
F61	6.3	5.8	6.6	6.6	7.2	0.5 to 0.8	1.9
F80	6.3	7.7	6.6	6.6	7.2	0.5 to 0.8	1.9
H70	8	6.7	8.3	8.3	9.0	0.7 to 1.1	3.1
H80	8	7.7	8.3	8.3	9.0	0.7 to 1.1	3.1
HA0	8	10.0	8.3	8.3	9.0	0.7 to 1.1	3.1
HC0	8	12.0	8.3	8.3	9.0	0.7 to 1.1	3.1
J80	10	7.7	10.3	10.3	11.0	0.7 to 1.1	4.5
JA0	10	10.0	10.3	10.3	11.0	0.7 to 1.1	4.5
JC0	10	12.2	10.3	10.3	11.0	0.7 to 1.1	4.5

◆ MARKING

EX) 2.5V390μF



◆ PART NUMBERING SYSTEM

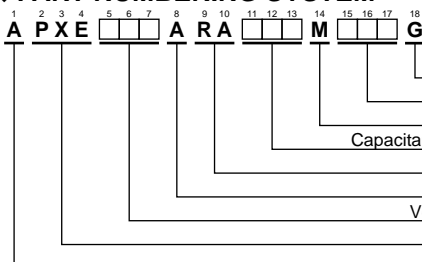

Supplement code
Size code
Capacitance tolerance code
Capacitance code (ex. 47μF:470,100μF:101)
Taping code
Terminal code
Voltage code (ex. 6.3V:6R3,10V:100)
Series code
Category

Please refer to "Product code guide (conductive polymer type)"

◆STANDARD RATINGS

WV (Vdc)	Cap (μF)	Size code	Leakage current (μAmax/after 2min.)	ESR (mΩmax/20°C, 100k to 300kHz)	Rated ripple current (mA _{rms} /105°C, 100kHz)	Part No.
2.5	180	E61	90	21	2,670	APXE2R5ARA181ME61G
	390	F61	195	15	3,160	APXE2R5ARA391MF61G
	470	F80	235	13	3,600	APXE2R5ARA471MF80G
	560	F61	700	16	3,500	APXE2R5ARA561MF61G
	560	F80	280	13	3,600	APXE2R5ARA561MF80G
	560	H70	280	13	4,100	APXE2R5ARA561MH70G
	680	H70	340	13	4,100	APXE2R5ARA681MH70G
	820	H80	410	12	4,260	APXE2R5ARA821MH80G
	820	HCO	410	9	5,400	APXE2R5ARA821MHC0G
	1,000	H80	500	12	4,260	APXE2R5ARA102MH80G
	1,200	J80	600	13	4,450	APXE2R5ARA122MJ80G
	1,500	HA0	750	10	5,220	APXE2R5ARA152MHA0G
	1,500	HCO	750	9	5,400	APXE2R5ARA152MHC0G
	2,200	JA0	1,100	10	5,500	APXE2R5ARA222MJA0G
2,700	JCO	1,350	9	5,600	APXE2R5ARA272MJC0G	
4	100	E61	80	22	2,610	APXE4R0ARA101ME61G
	150	E61	120	22	2,610	APXE4R0ARA151ME61G
	270	F61	216	15	3,160	APXE4R0ARA271MF61G
	330	F61	264	15	3,160	APXE4R0ARA331MF61G
	390	F80	312	14	3,470	APXE4R0ARA391MF80G
	470	H70	376	14	3,950	APXE4R0ARA471MH70G
	560	H70	448	14	3,950	APXE4R0ARA561MH70G
	680	H80	544	13	3,950	APXE4R0ARA681MH80G
	1,000	HA0	800	10	5,220	APXE4R0ARA102MHA0G
	1,000	J80	800	14	4,300	APXE4R0ARA102MJ80G
	1,200	HCO	960	9	5,400	APXE4R0ARA122MHC0G
	1,200	JA0	960	10	5,500	APXE4R0ARA122MJA0G
	1,500	JA0	1,200	10	5,500	APXE4R0ARA152MJA0G
	1,800	JA0	1,440	10	5,500	APXE4R0ARA182MJA0G
1,800	JCO	1,440	9	5,600	APXE4R0ARA182MJC0G	
6.3	100	E61	126	24	2,500	APXE6R3ARA101ME61G
	120	E61	151	24	2,500	APXE6R3ARA121ME61G
	220	F61	277	15	3,160	APXE6R3ARA221MF61G
	270	F80	340	14	3,470	APXE6R3ARA271MF80G
	330	F61	700	17	3,390	APXE6R3ARA331MF61G
	330	F80	415	14	3,470	APXE6R3ARA331MF80G
	330	H70	415	14	3,950	APXE6R3ARA331MH70G
	390	H70	491	14	3,950	APXE6R3ARA391MH70G
	470	H80	592	13	3,950	APXE6R3ARA471MH80G
	820	HA0	1,030	12	4,770	APXE6R3ARA821MHA0G
	820	HCO	1,030	10	5,150	APXE6R3ARA821MHC0G
	820	J80	1,030	14	4,300	APXE6R3ARA821MJ80G
	1,200	JA0	1,510	12	5,025	APXE6R3ARA122MJA0G
	1,500	JA0	1,890	12	5,025	APXE6R3ARA152MJA0G
1,500	JCO	1,890	10	5,500	APXE6R3ARA152MJC0G	
10	47	E61	94	28	2,310	APXE100ARA470ME61G
	56	E61	112	28	2,310	APXE100ARA560ME61G
	68	E61	136	28	2,310	APXE100ARA680ME61G
	120	F61	240	25	2,530	APXE100ARA121MF61G
	150	F80	300	21	2,880	APXE100ARA151MF80G
	220	H70	440	21	3,220	APXE100ARA221MH70G
	270	H70	540	21	3,220	APXE100ARA271MH70G
	330	H80	660	19	3,390	APXE100ARA331MH80G
	390	HA0	780	17	4,000	APXE100ARA391MHA0G
	470	J80	940	19	3,800	APXE100ARA471MJ80G
680	JA0	1,360	13	4,820	APXE100ARA681MJA0G	
16	33	E61	105	35	2,070	APXE160ARA330ME61G
	39	E61	124	35	2,070	APXE160ARA390ME61G
	68	F61	217	28	2,390	APXE160ARA680MF61G
	82	F80	262	24	2,700	APXE160ARA820MF80G
	100	F80	320	24	2,700	APXE160ARA101MF80G
	100	H70	320	24	3,010	APXE160ARA101MH70G
	120	H70	384	24	3,010	APXE160ARA121MH70G
	150	H80	480	22	3,150	APXE160ARA151MH80G
	180	HA0	576	18	3,890	APXE160ARA181MHA0G
	220	HA0	704	18	3,890	APXE160ARA221MHA0G
	220	J80	704	22	3,450	APXE160ARA221MJ80G
	330	JA0	1,050	16	4,350	APXE160ARA331MJA0G

NPCAP™-PXA Series

- Super low ESR, impedance and high heat resistance have been obtained by using conductive polymer as electrolyte
- Rated voltage range : 2.5 to 25V_{dc}, case size range : φ4×5.2L to φ10×12.2L
- Suitable for DC-DC converters, voltage regulators and decoupling applications used on computer motherboards etc.
- RoHS Compliant

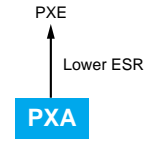

◆ SPECIFICATIONS

Items	Characteristics										
Category											
Temperature Range	-55 to +105°C										
Rated Voltage Range	2.5 to 25V _{dc}										
Capacitance Tolerance	±20% (M) (at 20°C, 120Hz)										
Surge Voltage	Rated voltage×1.15 (Rated voltage 2.5 to 20V _{dc} , 25V _{dc}) / Rated voltage×1.00 (Rated voltage 23V _{dc}) (at 105°C)										
Leakage Current	Shall not exceed values shown in STANDARD RATINGS. (at 20°C after 2 minutes)										
Dissipation Factor (tanδ)	0.12 max. (at 20°C, 120Hz)										
Low Temperature Characteristics (Max. Impedance Ratio)	Z(-25°C)/Z(+20°C) ≤ 1.15 Z(-55°C)/Z(+20°C) ≤ 1.25 (at 100kHz)										
Endurance	The following specifications shall be satisfied when the capacitors are restored to 20°C after the rated voltage is applied for 2,000 hours (F45 : 1,000 hours) at 105°C. <table border="1"> <tr><td>Appearance</td><td>No significant damage</td></tr> <tr><td>Capacitance change</td><td>≤ ±20% of the initial value</td></tr> <tr><td>DF (tanδ)</td><td>≤ 150% of the initial specified value</td></tr> <tr><td>ESR</td><td>≤ 150% of the initial specified value</td></tr> <tr><td>Leakage current</td><td>≤ The initial specified value</td></tr> </table>	Appearance	No significant damage	Capacitance change	≤ ±20% of the initial value	DF (tanδ)	≤ 150% of the initial specified value	ESR	≤ 150% of the initial specified value	Leakage current	≤ The initial specified value
Appearance	No significant damage										
Capacitance change	≤ ±20% of the initial value										
DF (tanδ)	≤ 150% of the initial specified value										
ESR	≤ 150% of the initial specified value										
Leakage current	≤ The initial specified value										
Bias Humidity	The following specifications shall be satisfied when the capacitors are restored to 20°C after subjecting them to the DC rated voltage at 60°C, 90 to 95% RH for 1,000 hours (F45 : 500 hours). <table border="1"> <tr><td>Appearance</td><td>No significant damage</td></tr> <tr><td>Capacitance change</td><td>≤ ±20% of the initial value</td></tr> <tr><td>DF (tanδ)</td><td>≤ 150% of the initial specified value</td></tr> <tr><td>ESR</td><td>≤ 150% of the initial specified value</td></tr> <tr><td>Leakage current</td><td>≤ The initial specified value</td></tr> </table>	Appearance	No significant damage	Capacitance change	≤ ±20% of the initial value	DF (tanδ)	≤ 150% of the initial specified value	ESR	≤ 150% of the initial specified value	Leakage current	≤ The initial specified value
Appearance	No significant damage										
Capacitance change	≤ ±20% of the initial value										
DF (tanδ)	≤ 150% of the initial specified value										
ESR	≤ 150% of the initial specified value										
Leakage current	≤ The initial specified value										
Surge Voltage	The capacitors shall be subjected to 1,000 cycles each consisting of charge with the surge voltage specified at 105°C for 30 seconds through a protective resistor (R=1kΩ) and discharge for 5 minutes 30 seconds. <table border="1"> <tr><td>Appearance</td><td>No significant damage</td></tr> <tr><td>Capacitance change</td><td>≤ ±20% of the initial value</td></tr> <tr><td>DF (tanδ)</td><td>≤ 150% of the initial specified value</td></tr> <tr><td>ESR</td><td>≤ 150% of the initial specified value</td></tr> <tr><td>Leakage current</td><td>≤ The initial specified value</td></tr> </table>	Appearance	No significant damage	Capacitance change	≤ ±20% of the initial value	DF (tanδ)	≤ 150% of the initial specified value	ESR	≤ 150% of the initial specified value	Leakage current	≤ The initial specified value
Appearance	No significant damage										
Capacitance change	≤ ±20% of the initial value										
DF (tanδ)	≤ 150% of the initial specified value										
ESR	≤ 150% of the initial specified value										
Leakage current	≤ The initial specified value										
Failure Rate	0.5% per 1,000 hours maximum (Confidence level 60% at 105°C)										

*Note : If any doubt arises, measure the leakage current after the following voltage treatment.
Voltage treatment : DC rated voltage is applied to the capacitors for 120 minutes at 105°C.

◆ DIMENSIONS [mm]

● Terminal Code : A

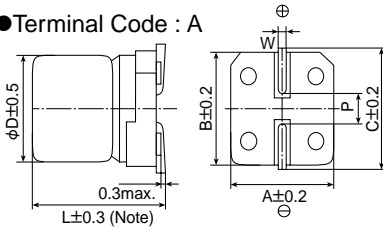

Note : L+0.1/-0.2 for F45
L±0.5 for HC0 and JC0

Size code	φD	L	A	B	C	W	P
D55	4	5.2	4.3	4.3	5.1	0.5 to 0.8	1.0
E60	5	5.7	5.3	5.3	5.9	0.5 to 0.8	1.4
F45	6.3	4.4	6.6	6.6	7.2	0.5 to 0.8	1.9
F55	6.3	5.2	6.6	6.6	7.2	0.5 to 0.8	1.9
F60	6.3	5.7	6.6	6.6	7.2	0.5 to 0.8	1.9
H70	8	6.7	8.3	8.3	9.0	0.7 to 1.1	3.1
HC0	8	12.0	8.3	8.3	9.0	0.7 to 1.1	3.1
J80	10	7.7	10.3	10.3	11.0	0.7 to 1.1	4.5
JC0	10	12.2	10.3	10.3	11.0	0.7 to 1.1	4.5

◆ MARKING

EX) 16V39μF



◆ PART NUMBERING SYSTEM

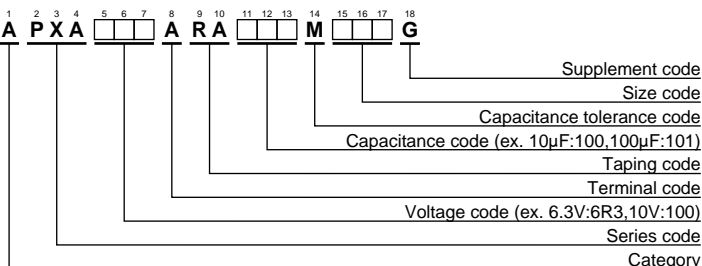

Please refer to "Product code guide (conductive polymer type)"

◆ **STANDARD RATINGS**

WV (Vdc)	Cap (μF)	Size code	Leakage current (μAmax/ after 2 min.)	ESR (mΩmax/ 20°C, 100k to 300kHz)	Rated ripple current (mArms/105°C, 100kHz)	Part No.	WV (Vdc)	Cap (μF)	Size code	Leakage current (μAmax/ after 2 min.)	ESR (mΩmax/ 20°C, 100k to 300kHz)	Rated ripple current (mArms/105°C, 100kHz)	Part No.
2.5	220	F55	110	25	2,500	APXA2R5ARA221MF55G	10	4.7	D55	24	240	670	APXA100ARA4R7MD55G
	220	F60	110	25	2,500	APXA2R5ARA221MF60G		6.8	D55	34	240	670	APXA100ARA6R8MD55G
	560	H70	280	23	3,100	APXA2R5ARA561MH70G		10	D55	50	220	700	APXA100ARA100MD55G
	680	HCO	340	12	4,770	APXA2R5ARA681MHC0G		15	D55	75	200	740	APXA100ARA150MD55G
	1,000	J80	500	19	4,240	APXA2R5ARA102MJ80G		33	E60	66	40	1,270	APXA100ARA330ME60G
4	1,500	JC0	750	10	5,500	APXA2R5ARA152MJC0G		47	E60	94	40	1,270	APXA100ARA470ME60G
	33	D55	66	200	740	APXA4R0ARA330MD55G		47	F45	235	41	1,560	APXA100ARA470MF45G
	100	F55	80	26	2,450	APXA4R0ARA101MF55G		47	F60	94	31	2,250	APXA100ARA470MF60G
	100	F60	80	26	2,450	APXA4R0ARA101MF60G		56	F55	112	31	2,250	APXA100ARA560MF55G
	120	F45	240	38	1,710	APXA4R0ARA121MF45G		56	F60	112	31	2,250	APXA100ARA560MF60G
	150	E60	120	30	1,490	APXA4R0ARA151ME60G		120	H70	240	27	2,800	APXA100ARA121MH70G
	150	F55	120	26	2,450	APXA4R0ARA151MF55G		150	H70	300	27	2,800	APXA100ARA150MH70G
	150	F60	120	26	2,450	APXA4R0ARA151MF60G		270	HCO	540	14	4,420	APXA100ARA271MHC0G
	220	H70	176	25	3,020	APXA4R0ARA221MH70G		270	J80	540	24	3,770	APXA100ARA271MJ80G
	330	H70	264	25	3,020	APXA4R0ARA331MH70G		330	HCO	660	14	4,420	APXA100ARA331MHC0G
	470	J80	376	20	4,130	APXA4R0ARA471MJ80G	330	J80	660	24	3,770	APXA100ARA331MJ80G	
	560	HCO	448	12	4,770	APXA4R0ARA561MHC0G	470	JC0	940	12	5,300	APXA100ARA471MJC0G	
	680	J80	544	20	4,130	APXA4R0ARA681MJ80G	560	JC0	1,120	12	5,300	APXA100ARA561MJC0G	
820	JC0	656	10	5,500	APXA4R0ARA821MJC0G	16	3.3	D55	26	260	660	APXA160ARA3R3MD55G	
1,200	JC0	960	10	5,500	APXA4R0ARA122MJC0G		22	E60	70	45	1,210	APXA160ARA220ME60G	
6.3	22	D55	69	200	740		APXA6R3ARA220MD55G	22	F45	176	45	1,490	APXA160ARA220MF45G
	47	E60	59	35	1,380		APXA6R3ARA470ME60G	33	F60	106	37	2,050	APXA160ARA330MF60G
	68	F60	86	27	2,400		APXA6R3ARA680MF60G	39	F55	125	37	2,050	APXA160ARA390MF55G
	82	F45	267	40	1,670		APXA6R3ARA820MF45G	39	F60	125	37	2,050	APXA160ARA390MF60G
	82	F55	103	27	2,400		APXA6R3ARA820MF55G	82	H70	262	30	2,700	APXA160ARA820MH70G
	82	F60	103	27	2,400		APXA6R3ARA820MF60G	150	J80	480	26	3,430	APXA160ARA151MJ80G
	100	E60	126	35	1,380		APXA6R3ARA101ME60G	180	HCO	576	16	4,360	APXA160ARA181MHC0G
	100	F45	315	40	1,670		APXA6R3ARA101MF45G	180	J80	576	26	3,430	APXA160ARA181MJ80G
	100	F55	126	27	2,400		APXA6R3ARA101MF55G	220	JC0	704	14	5,050	APXA160ARA221MJC0G
	100	F60	126	27	2,400	APXA6R3ARA101MF60G	330	JC0	1,056	14	5,050	APXA160ARA331MJC0G	
	120	F60	151	27	2,400	APXA6R3ARA121MF60G	20	15	F45	150	57	1,300	APXA200ARA150MF45G
	150	H70	189	25	3,020	APXA6R3ARA151MH70G		22	F55	88	50	1,650	APXA200ARA220MF55G
	220	H70	277	25	3,020	APXA6R3ARA221MH70G		22	F60	88	50	1,650	APXA200ARA220MF60G
	330	J80	416	20	4,130	APXA6R3ARA331MJ80G		39	H70	156	45	2,000	APXA200ARA390MH70G
	390	HCO	491	12	4,770	APXA6R3ARA391MHC0G		47	H70	188	45	2,000	APXA200ARA470MH70G
	470	HCO	592	12	4,770	APXA6R3ARA471MHC0G		82	J80	328	40	2,500	APXA200ARA820MJ80G
	470	J80	592	20	4,130	APXA6R3ARA471MJ80G	150	JC0	600	20	4,320	APXA200ARA151MJC0G	
680	JC0	857	10	5,500	APXA6R3ARA681MJC0G	23	15	F45	172	57	1,300	APXA230ARA150MF45G	
820	JC0	1,033	10	5,500	APXA6R3ARA821MJC0G		10	F60	125	65	1,500	APXA250ARA100MF60G	
25	22	H70	275	50	1,800		APXA250ARA220MH70G	22	H70	275	50	1,800	APXA250ARA220MH70G
	39	J80	488	45	2,100	APXA250ARA390MJ80G	39	J80	488	45	2,100	APXA250ARA390MJ80G	

NPCAP™-PXH Series

- Super low ESR, impedance and high heat resistance have been obtained by using conductive polymer as electrolyte.
- Suitable for DC-DC converters, voltage regulators and decoupling applications.
- Endurance : 125°C 1,000 hours
- Rated voltage range : 2.5 to 20V_{dc}, Capacitance range : 22 to 1,000μF
- Case size range : φ6.3×5.7L to φ10×7.7L
- RoHS Compliant

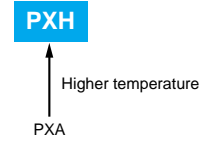

◆SPECIFICATIONS

Items	Characteristics										
Category Temperature Range	-55 to +125°C										
Rated Voltage Range	2.5 to 20V _{dc}										
Capacitance Tolerance	±20% (M) (at 20°C, 120Hz)										
Surge Voltage	Rated voltage×1.15 (at 105°C)										
Leakage Current	Shall not exceed values shown in STANDARD RATINGS. (at 20°C after 2 minutes)										
Dissipation Factor (tanδ)	0.12 max. (at 20°C, 120Hz)										
Low Temperature Characteristics (Max. Impedance Ratio)	Z(-25°C)/Z(+20°C)≤1.15 Z(-55°C)/Z(+20°C)≤1.25 (at 100kHz)										
Endurance	The following specifications shall be satisfied when the capacitors are restored to 20°C after the rated voltage is applied for 1,000 hours at 125°C. <table border="1"> <tr><td>Appearance</td><td>No significant damage</td></tr> <tr><td>Capacitance change</td><td>≤±20% of the initial value</td></tr> <tr><td>DF (tanδ)</td><td>≤200% of the initial specified value</td></tr> <tr><td>ESR</td><td>≤200% of the initial specified value</td></tr> <tr><td>Leakage current</td><td>≤The initial specified value</td></tr> </table>	Appearance	No significant damage	Capacitance change	≤±20% of the initial value	DF (tanδ)	≤200% of the initial specified value	ESR	≤200% of the initial specified value	Leakage current	≤The initial specified value
Appearance	No significant damage										
Capacitance change	≤±20% of the initial value										
DF (tanδ)	≤200% of the initial specified value										
ESR	≤200% of the initial specified value										
Leakage current	≤The initial specified value										
Bias Humidity	The following specifications shall be satisfied when the capacitors are restored to 20°C after subjecting them to the DC rated voltage at 60°C, 90 to 95% RH for 1,000 hours. <table border="1"> <tr><td>Appearance</td><td>No significant damage</td></tr> <tr><td>Capacitance change</td><td>≤±20% of the initial value</td></tr> <tr><td>DF (tanδ)</td><td>≤150% of the initial specified value</td></tr> <tr><td>ESR</td><td>≤150% of the initial specified value</td></tr> <tr><td>Leakage current</td><td>≤The initial specified value</td></tr> </table>	Appearance	No significant damage	Capacitance change	≤±20% of the initial value	DF (tanδ)	≤150% of the initial specified value	ESR	≤150% of the initial specified value	Leakage current	≤The initial specified value
Appearance	No significant damage										
Capacitance change	≤±20% of the initial value										
DF (tanδ)	≤150% of the initial specified value										
ESR	≤150% of the initial specified value										
Leakage current	≤The initial specified value										
Surge Voltage	The capacitors shall be subjected to 1,000 cycles each consisting of charge with the surge voltage specified at 105°C for 30 seconds through a protective resistor(R=1kΩ) and discharge for 5 minutes 30 seconds. <table border="1"> <tr><td>Appearance</td><td>No significant damage</td></tr> <tr><td>Capacitance change</td><td>≤±20% of the initial value</td></tr> <tr><td>DF (tanδ)</td><td>≤150% of the initial specified value</td></tr> <tr><td>ESR</td><td>≤150% of the initial specified value</td></tr> <tr><td>Leakage current</td><td>≤The initial specified value</td></tr> </table>	Appearance	No significant damage	Capacitance change	≤±20% of the initial value	DF (tanδ)	≤150% of the initial specified value	ESR	≤150% of the initial specified value	Leakage current	≤The initial specified value
Appearance	No significant damage										
Capacitance change	≤±20% of the initial value										
DF (tanδ)	≤150% of the initial specified value										
ESR	≤150% of the initial specified value										
Leakage current	≤The initial specified value										
Failure Rate	0.5% per 1,000 hours maximum (Confidence level 60% at 125°C)										

*Note : If any doubt arises, measure the leakage current after the following voltage treatment.
Voltage treatment : DC rated voltage is applied to the capacitors for 120 minutes at 125°C.

◆DIMENSIONS [mm]

● Terminal Code : A

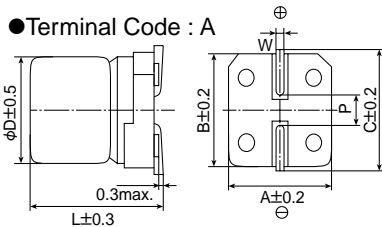

Size code	φD	L	A	B	C	W	P
F60	6.3	5.7	6.6	6.6	7.2	0.5 to 0.8	1.9
H70	8	6.7	8.3	8.3	9.0	0.7 to 1.1	3.1
J80	10	7.7	10.3	10.3	11.0	0.7 to 1.1	4.5

◆MARKING

EX) 20V22μF



◆PART NUMBERING SYSTEM



- Supplement code
- Size code
- Capacitance tolerance code
- Capacitance code (ex. 22μF:220,100μF:101)
- Taping code
- Terminal code
- Voltage code (ex. 6.3V:6R3,10V:100)
- Series code
- Category

Please refer to "Product code guide (conductive polymer type)"

NPCAP™-PXH Series
◆STANDARD RATINGS

WV(Vdc)	Cap(μF)	Size code	Leakage current (μAmax/after 2min.)	ESR (mΩmax/20°C, 100k to 300kHz)	Rated ripple current (mArms/100kHz)		Part No.
					-55°C to +105°C	+105°C to +125°C	
2.5	220	F60	110	35	2,500	770	APXH2R5ARA221MF60G
	560	H70	280	30	3,100	960	APXH2R5ARA561MH70G
	1,000	J80	500	25	3,700	1,100	APXH2R5ARA102MJ80G
4	150	F60	120	35	2,450	770	APXH4R0ARA151MF60G
	220	H70	176	30	3,020	960	APXH4R0ARA221MH70G
	680	J80	544	25	3,700	1,100	APXH4R0ARA681MJ80G
6.3	82	F60	103	40	2,400	720	APXH6R3ARA820MF60G
	100	F60	126	40	2,400	720	APXH6R3ARA101MF60G
	150	H70	189	30	3,020	960	APXH6R3ARA151MH70G
	220	H70	277	30	3,020	960	APXH6R3ARA221MH70G
	470	J80	592	25	3,700	1,100	APXH6R3ARA471MJ80G
10	56	F60	112	45	2,250	680	APXH100ARA560MF60G
	120	H70	240	35	2,800	880	APXH100ARA121MH70G
	150	H70	300	35	2,800	880	APXH100ARA151MH70G
	330	J80	660	30	3,700	1,010	APXH100ARA331MJ80G
16	39	F60	125	50	2,050	650	APXH160ARA390MF60G
	82	H70	262	40	2,700	830	APXH160ARA820MH70G
	150	J80	480	35	3,020	930	APXH160ARA151MJ80G
	180	J80	576	35	3,020	930	APXH160ARA181MJ80G
20	22	F60	88	60	1,650	590	APXH200ARA220MF60G
	47	H70	188	45	2,000	780	APXH200ARA470MH70G
	82	J80	328	45	2,400	820	APXH200ARA820MJ80G

New!

NPCAP™-PSF Series

- Super low ESR, high ripple current capability
- ESR 5mΩ max. (2.5V_{dc})
- Longer life (5,000 hours at 105°C)
- ESR after endurance is specified within the initial spec (2.5V_{dc})
- Rated voltage range : 2.5 to 16V_{dc}
- RoHS Compliant
- Halogen Free (Ask Engineering Bulletin No797 in detail)

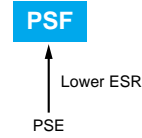

◆ SPECIFICATIONS

Items	Characteristics											
Category												
Temperature Range	-55 to +105°C											
Rated Voltage Range	2.5 to 16V _{dc}											
Capacitance Tolerance	±20% (M) (at 20°C, 120Hz)											
Surge Voltage	Rated voltage(V)×1.15 (at 105°C)											
Leakage Current	I=0.2CV or 500μA, whichever is greater											
*Note	Where, I : Leakage current (μA), C : Nominal capacitance (μF), V : Rated voltage (V) (at 20°C after 2 minutes)											
Dissipation Factor (tanδ)	0.10 max. (at 20°C, 120Hz)											
Low Temperature Characteristics (Max.Impedance Ratio)	Z(-25°C)/Z(+20°C)≤1.15 Z(-55°C)/Z(+20°C)≤1.25 (at 100kHz)											
Endurance	The following specifications shall be satisfied when the capacitors are restored to 20°C after the rated voltage is applied for 5,000 hours at 105°C.											
	<table border="1"> <tr> <td>Appearance</td> <td>No significant damage</td> </tr> <tr> <td>Capacitance change</td> <td>≤±20% of the initial value</td> </tr> <tr> <td>D.F. (tanδ)</td> <td>≤The initial specified value</td> </tr> <tr> <td rowspan="2">ESR</td> <td>2.5V_{dc} : ≤The initial specified value</td> </tr> <tr> <td>16V_{dc} : ≤150% of the initial specified value</td> </tr> <tr> <td>Leakage current</td> <td>≤The initial specified value</td> </tr> </table>	Appearance	No significant damage	Capacitance change	≤±20% of the initial value	D.F. (tanδ)	≤The initial specified value	ESR	2.5V _{dc} : ≤The initial specified value	16V _{dc} : ≤150% of the initial specified value	Leakage current	≤The initial specified value
Appearance	No significant damage											
Capacitance change	≤±20% of the initial value											
D.F. (tanδ)	≤The initial specified value											
ESR	2.5V _{dc} : ≤The initial specified value											
	16V _{dc} : ≤150% of the initial specified value											
Leakage current	≤The initial specified value											
Bias Humidity Test	The following specifications shall be satisfied when the capacitors are restored to 20°C after subjecting them to DC voltage at 60°C, 90 to 95% RH for 1,000 hours.											
	<table border="1"> <tr> <td>Appearance</td> <td>No significant damage</td> </tr> <tr> <td>Capacitance change</td> <td>≤±20% of the initial value</td> </tr> <tr> <td>D.F. (tanδ)</td> <td>≤The initial specified value</td> </tr> <tr> <td rowspan="2">ESR</td> <td>2.5V_{dc} : ≤The initial specified value</td> </tr> <tr> <td>16V_{dc} : ≤150% of the initial specified value</td> </tr> <tr> <td>Leakage current</td> <td>≤The initial specified value</td> </tr> </table>	Appearance	No significant damage	Capacitance change	≤±20% of the initial value	D.F. (tanδ)	≤The initial specified value	ESR	2.5V _{dc} : ≤The initial specified value	16V _{dc} : ≤150% of the initial specified value	Leakage current	≤The initial specified value
Appearance	No significant damage											
Capacitance change	≤±20% of the initial value											
D.F. (tanδ)	≤The initial specified value											
ESR	2.5V _{dc} : ≤The initial specified value											
	16V _{dc} : ≤150% of the initial specified value											
Leakage current	≤The initial specified value											
Surge Voltage Test	The capacitors shall be subjected to 1,000 cycles each consisting of charge with the surge voltage specified at 105°C for 30 seconds through a protective resistor(R=1kΩ) and discharge for 5 minutes 30 seconds.											
	<table border="1"> <tr> <td>Appearance</td> <td>No significant damage</td> </tr> <tr> <td>Capacitance change</td> <td>≤±20% of the initial value</td> </tr> <tr> <td>D.F. (tanδ)</td> <td>≤The initial specified value</td> </tr> <tr> <td rowspan="2">ESR</td> <td>2.5V_{dc} : ≤The initial specified value</td> </tr> <tr> <td>16V_{dc} : ≤150% of the initial specified value</td> </tr> <tr> <td>Leakage current</td> <td>≤The initial specified value</td> </tr> </table>	Appearance	No significant damage	Capacitance change	≤±20% of the initial value	D.F. (tanδ)	≤The initial specified value	ESR	2.5V _{dc} : ≤The initial specified value	16V _{dc} : ≤150% of the initial specified value	Leakage current	≤The initial specified value
Appearance	No significant damage											
Capacitance change	≤±20% of the initial value											
D.F. (tanδ)	≤The initial specified value											
ESR	2.5V _{dc} : ≤The initial specified value											
	16V _{dc} : ≤150% of the initial specified value											
Leakage current	≤The initial specified value											
Failure Rate	0.5% per 1,000 hours maximum (Confidence level 60% at 105°C)											

*Note : If any doubt arises, measure the leakage current after the following voltage treatment.
Voltage treatment : DC rated voltage is applied to the capacitors for 120 minutes at 105°C.

◆ DIMENSIONS [mm]

● Terminal Code : E

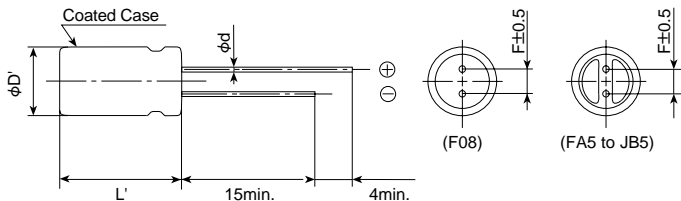

Size code	F08	FA5	HB5	JB5
φD	6.3		8.0	10.0
φd	0.6	0.5	0.6	
F	2.5			
φD'	φD+0.5max.			
L'	L+1.0max.	L+0.3max.	L+1.5max.	

◆ MARKING

EX) 2.5V560μF



◆PART NUMBERING SYSTEM

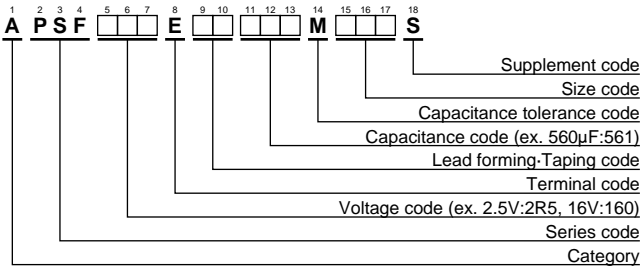

Please refer to "Product code guide (conductive polymer type)"

◆STANDARD RATINGS

WV(Vdc)	Cap(μF)	Case size φD×L(mm)	ESR (mΩ max./20°C, 100k to 300kHz)	Rated ripple current (mA _{rms} /105°C, 100kHz)	Part No.
2.5	330	6.3×8	5	5,900	APSF2R5E□□331MF08S
	470	6.3×8	5	5,900	APSF2R5E□□471MF08S
	560	6.3×8	5	5,900	APSF2R5E□□561MF08S
16	100	6.3×10.5	25	2,820	APSF160E□□101MFA5S
	270	8×11.5	11	5,080	APSF160E□□271MHB5S
	470	10×11.5	10	6,100	APSF160E□□471MJB5S

□□ : Enter the appropriate lead forming or taping code.

New!
NPCAP™-PSE Series

- Super low ESR, high ripple current capability
- Downsized from PSC series (φ8×8L to φ6.3×8L)
- Endurance is longer life than PSC series (5,000 hours at 105°C)
- ESR after endurance is specified within the initial spec
- Rated voltage range : 2.5 to 6.3V_{dc}
- RoHS Compliant
- Halogen Free (Ask Engineering Bulletin No795 in detail)

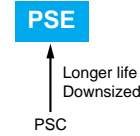

◆ SPECIFICATIONS

Items	Characteristics										
Category											
Temperature Range	-55 to +105°C										
Rated Voltage Range	2.5 to 6.3V _{dc}										
Capacitance Tolerance	±20% (M) (at 20°C, 120Hz)										
Surge Voltage	Rated voltage(V)×1.15 (at 105°C)										
Leakage Current	I=0.2CV or 500μA, whichever is greater (at 20°C after 2 minutes)										
*Note Where, I : Max. leakage current (μA), C : Nominal capacitance (μF), V : Rated voltage (V)											
Dissipation Factor (tanδ)	0.10 max. (at 20°C, 120Hz)										
Low Temperature Characteristics (Max.Impedance Ratio)	Z(-25°C)/Z(+20°C)≤1.15 Z(-55°C)/Z(+20°C)≤1.25 (at 100kHz)										
Endurance	The following specifications shall be satisfied when the capacitors are restored to 20°C after the rated voltage is applied for 5,000 hours at 105°C.										
<table border="1"> <tr><td>Appearance</td><td>No significant damage</td></tr> <tr><td>Capacitance change</td><td>≤±20% of the initial value</td></tr> <tr><td>D.F. (tanδ)</td><td>≤The initial specified value</td></tr> <tr><td>ESR</td><td>≤The initial specified value</td></tr> <tr><td>Leakage current</td><td>≤The initial specified value</td></tr> </table>		Appearance	No significant damage	Capacitance change	≤±20% of the initial value	D.F. (tanδ)	≤The initial specified value	ESR	≤The initial specified value	Leakage current	≤The initial specified value
Appearance	No significant damage										
Capacitance change	≤±20% of the initial value										
D.F. (tanδ)	≤The initial specified value										
ESR	≤The initial specified value										
Leakage current	≤The initial specified value										
Bias Humidity Test	The following specifications shall be satisfied when the capacitors are restored to 20°C after subjecting them to DC voltage at 60°C, 90 to 95% RH for 1,000 hours.										
<table border="1"> <tr><td>Appearance</td><td>No significant damage</td></tr> <tr><td>Capacitance change</td><td>≤±20% of the initial value</td></tr> <tr><td>D.F. (tanδ)</td><td>≤The initial specified value</td></tr> <tr><td>ESR</td><td>≤The initial specified value</td></tr> <tr><td>Leakage current</td><td>≤The initial specified value</td></tr> </table>		Appearance	No significant damage	Capacitance change	≤±20% of the initial value	D.F. (tanδ)	≤The initial specified value	ESR	≤The initial specified value	Leakage current	≤The initial specified value
Appearance	No significant damage										
Capacitance change	≤±20% of the initial value										
D.F. (tanδ)	≤The initial specified value										
ESR	≤The initial specified value										
Leakage current	≤The initial specified value										
Surge Voltage Test	The capacitors shall be subjected to 1,000 cycles each consisting of charge with the surge voltage specified at 105°C for 30 seconds through a protective resistor(R=1kΩ) and discharge for 5 minutes 30 seconds.										
<table border="1"> <tr><td>Appearance</td><td>No significant damage</td></tr> <tr><td>Capacitance change</td><td>≤±20% of the initial value</td></tr> <tr><td>D.F. (tanδ)</td><td>≤The initial specified value</td></tr> <tr><td>ESR</td><td>≤The initial specified value</td></tr> <tr><td>Leakage current</td><td>≤The initial specified value</td></tr> </table>		Appearance	No significant damage	Capacitance change	≤±20% of the initial value	D.F. (tanδ)	≤The initial specified value	ESR	≤The initial specified value	Leakage current	≤The initial specified value
Appearance	No significant damage										
Capacitance change	≤±20% of the initial value										
D.F. (tanδ)	≤The initial specified value										
ESR	≤The initial specified value										
Leakage current	≤The initial specified value										
Failure Rate	0.5% per 1,000 hours maximum (Confidence level 60% at 105°C)										

*Note : If any doubt arises, measure the leakage current after the following voltage treatment.
Voltage treatment : DC rated voltage is applied to the capacitors for 120 minutes at 105°C.

◆ DIMENSIONS [mm]

- Terminal Code : E

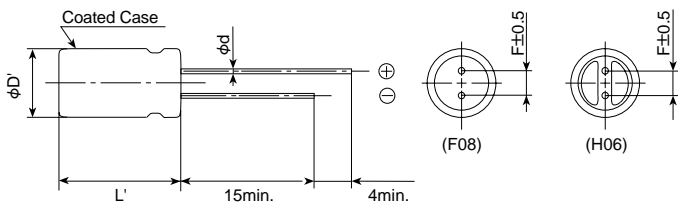

Size code	F08	H06
φD	6.3	8.0
φd	0.6	
F	2.5	3.5
φD'	φD+0.5max.	
L'	L+1.5max.	

◆ MARKING

EX) 2.5V820μF



◆PART NUMBERING SYSTEM

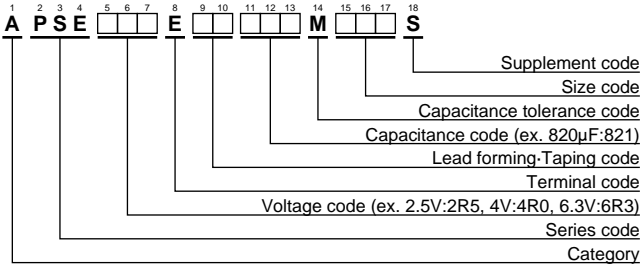

Please refer to "Product code guide (conductive polymer type)"

◆STANDARD RATINGS

WV(V _{dc})	Cap(μF)	Case size φDXL(mm)	ESR (mΩ max./20°C, 100k to 300kHz)	Rated ripple current (mA _{rms} /105°C, 100kHz)	Part No.
2.5	680	8×6	8	4,900	APSE2R5E□□681MH06S
	820	6.3×8	7	5,000	APSE2R5E□□821MF08S
4	560	6.3×8	7	5,000	APSE4R0E□□561MF08S
	470	6.3×8	8	4,700	APSE6R3E□□471MF08S
6.3	560	6.3×8	8	4,700	APSE6R3E□□561MF08S

□□ : Enter the appropriate lead forming or taping code.

NPCAP™-PSC Series

- Super low ESR, high ripple current capability
- Lower profile than PSA ($\phi 8 \times 8L$ to $\phi 10 \times 12.5L$)
- Rated voltage range : 2.5 to 16V_{dc}
- Nominal capacitance range : 270 to 2,700 μ F
- Endurance : 2,000 hours at 105°C
- Suitable for DC-DC converters, voltage regulators and decoupling applications for computer motherboards
- Added 2.5V 820 μ F (ESR 5m Ω max.)
- RoHS Compliant

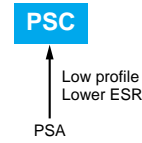

◆ SPECIFICATIONS

Items	Characteristics										
Category											
Temperature Range	-55 to +105°C										
Rated Voltage Range	2.5 to 16V _{dc}										
Capacitance Tolerance	±20% (M) (at 20°C, 120Hz)										
Surge Voltage	Rated voltage×1.15 (at 105°C)										
Leakage Current	I=0.2CV or 500 μ A, whichever is greater.										
*Note	Where, I : Max. leakage current (μ A), C : Nominal capacitance (μ F), V : Rated voltage (V _{dc}) (at 20°C after 2 minutes)										
Dissipation Factor (tan δ)	0.10 max. (at 20°C, 120Hz)										
Low Temperature Characteristics (Max.Impedance Ratio)	Z(-25°C)/Z(+20°C)≤1.15 Z(-55°C)/Z(+20°C)≤1.25 (at 100kHz)										
Endurance	The following specifications shall be satisfied when the capacitors are restored to 20°C after the rated voltage is applied for 2,000 hours at 105°C.										
	<table border="1"> <tr><td>Appearance</td><td>No significant damage</td></tr> <tr><td>Capacitance change</td><td>≤±20% of the initial value</td></tr> <tr><td>D.F. (tanδ)</td><td>≤150% of the initial specified value</td></tr> <tr><td>ESR</td><td>≤150% of the initial specified value</td></tr> <tr><td>Leakage current</td><td>≤The initial specified value</td></tr> </table>	Appearance	No significant damage	Capacitance change	≤±20% of the initial value	D.F. (tan δ)	≤150% of the initial specified value	ESR	≤150% of the initial specified value	Leakage current	≤The initial specified value
Appearance	No significant damage										
Capacitance change	≤±20% of the initial value										
D.F. (tan δ)	≤150% of the initial specified value										
ESR	≤150% of the initial specified value										
Leakage current	≤The initial specified value										
Bias Humidity Test	The following specifications shall be satisfied when the capacitors are restored to 20°C after subjecting them to DC voltage at 60°C, 90 to 95% RH for 1,000 hours.										
	<table border="1"> <tr><td>Appearance</td><td>No significant damage</td></tr> <tr><td>Capacitance change</td><td>≤±20% of the initial value</td></tr> <tr><td>D.F. (tanδ)</td><td>≤150% of the initial specified value</td></tr> <tr><td>ESR</td><td>≤150% of the initial specified value</td></tr> <tr><td>Leakage current</td><td>≤The initial specified value</td></tr> </table>	Appearance	No significant damage	Capacitance change	≤±20% of the initial value	D.F. (tan δ)	≤150% of the initial specified value	ESR	≤150% of the initial specified value	Leakage current	≤The initial specified value
Appearance	No significant damage										
Capacitance change	≤±20% of the initial value										
D.F. (tan δ)	≤150% of the initial specified value										
ESR	≤150% of the initial specified value										
Leakage current	≤The initial specified value										
Surge Voltage Test	The capacitors shall be subjected to 1,000 cycles each consisting of charge with the surge voltage specified at 105°C for 30 seconds through a protective resistor(R=1k Ω) and discharge for 5 minutes 30 seconds.										
	<table border="1"> <tr><td>Appearance</td><td>No significant damage</td></tr> <tr><td>Capacitance change</td><td>≤±20% of the initial value</td></tr> <tr><td>D.F. (tanδ)</td><td>≤150% of the initial specified value</td></tr> <tr><td>ESR</td><td>≤150% of the initial specified value</td></tr> <tr><td>Leakage current</td><td>≤The initial specified value</td></tr> </table>	Appearance	No significant damage	Capacitance change	≤±20% of the initial value	D.F. (tan δ)	≤150% of the initial specified value	ESR	≤150% of the initial specified value	Leakage current	≤The initial specified value
Appearance	No significant damage										
Capacitance change	≤±20% of the initial value										
D.F. (tan δ)	≤150% of the initial specified value										
ESR	≤150% of the initial specified value										
Leakage current	≤The initial specified value										
Failure Rate	0.5% per 1,000 hours maximum (Confidence level 60% at 105°C)										

*Note : If any doubt arises, measure the leakage current after the following voltage treatment.
Voltage treatment : DC rated voltage is applied to the capacitors for 120 minutes at 105°C.

◆ DIMENSIONS [mm]

- Terminal Code : E

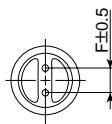
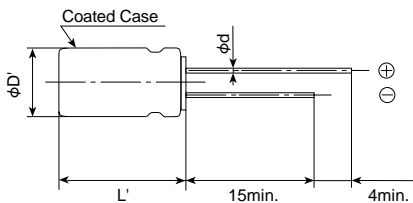

Size code	H08	HB5	JB5	JC5
ϕD	8.0	8.0	10.0	10.0
ϕd	0.6	0.8(Note1)	0.8(Note1)	0.6
F	3.5	3.5	5.0	5.0
$\phi D'$	$\phi D+0.5max.$			
L'	L+1.0max.	L+1.5max.		

Note1 : 0.6 for rated volt 16V.

◆ MARKING

EX) 2.5V820 μ F



NPCAP™-PSC Series

◆PART NUMBERING SYSTEM

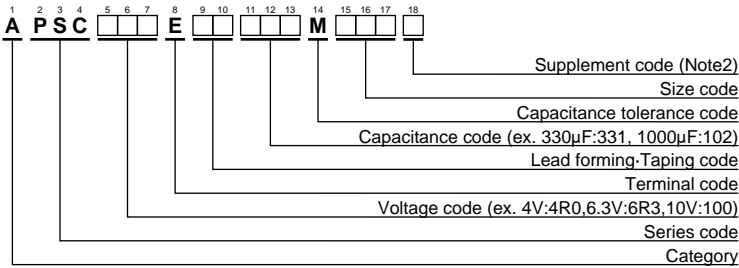

(Note2) PSC series, 2.5V820μF(ESR 5mΩ max.) has supplement code "J".
Can case, terminal and terminal plating are the same as all others in PSC series.

Please refer to "Product code guide (conductive polymer type)"

◆STANDARD RATINGS

WV(V _{dc})	Cap(μF)	Case size φDXL(mm)	ESR (mΩ max/20°C, 100k to 300kHz)	Rated ripple current (mArms/105°C, 100kHz)	Part No.
2.5	560	8×8	7	6,100	APSC2R5E□□561MH08S
	820	8×8	5	6,100	APSC2R5E□□821MH08J
	820	8×8	7	6,100	APSC2R5E□□821MH08S
	1,000	8×8	7	6,100	APSC2R5E□□102MH08S
	1,000	8×11.5	7	6,100	APSC2R5E□□102MHB5S
	1,500	8×11.5	7	6,100	APSC2R5E□□152MHB5S
	2,700	10×11.5	8	5,560	APSC2R5E□□272MJB5S
4	560	8×8	7	6,100	APSC4R0E□□561MH08S
	680	8×11.5	7	6,100	APSC4R0E□□681MHB5S
	1,000	10×11.5	6	6,640	APSC4R0E□□102MJB5S
6.3	470	8×8	8	5,700	APSC6R3E□□471MH08S
	560	8×8	8	5,700	APSC6R3E□□561MH08S
	820	10×11.5	7	6,640	APSC6R3E□□821MJB5S
	1,500	10×11.5	10	5,560	APSC6R3E□□152MJB5S
10	390	8×11.5	9	5,650	APSC100E□□391MHB5S
	680	10×11.5	7	6,100	APSC100E□□681MJB5S
16	270	8×11.5	11	5,080	APSC160E□□271MHB5S
	330	10×12.5	10	6,100	APSC160E□□331MJC5S
	470	10×11.5	10	6,100	APSC160E□□471MJB5S

□ : Enter the appropriate lead forming or taping code.

NPCAP™-PSA Series

- Super low ESR, high temperature resistance and high ripple current capability
- Rated voltage range : 2.5 to 16V_{dc}
- Endurance : 2,000 hours at 105°C
- Suitable for DC-DC converters, voltage regulators and decoupling applications for computer motherboards
- RoHS Compliant

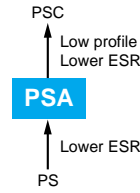

◆ SPECIFICATIONS

Items	Characteristics										
Category											
Temperature Range	-55 to +105°C										
Rated Voltage Range	2.5 to 16V _{dc}										
Capacitance Tolerance	±20% (M) (at 20°C, 120Hz)										
Surge Voltage	Rated voltage×1.15 (at 105°C)										
Leakage Current	I=0.2CV										
*Note	Where, I : Max. leakage current (μA), C : Nominal capacitance (μF), V : Rated voltage (V _{dc}) (at 20°C after 2 minutes)										
Dissipation Factor (tanδ)	0.08 max. (FA5 size : 0.12max.) (at 20°C, 120Hz)										
Low Temperature Characteristics (Max. Impedance Ratio)	Z(-25°C)/Z(+20°C)≤1.15 Z(-55°C)/Z(+20°C)≤1.25 (at 100kHz)										
Endurance	The following specifications shall be satisfied when the capacitors are restored to 20°C after the rated voltage is applied for 2,000 hours at 105°C.										
	<table border="1"> <tr> <td>Appearance</td> <td>No significant damage</td> </tr> <tr> <td>Capacitance change</td> <td>≤±20% of the initial value</td> </tr> <tr> <td>D.F. (tanδ)</td> <td>≤150% of the initial specified value</td> </tr> <tr> <td>ESR</td> <td>≤150% of the initial specified value</td> </tr> <tr> <td>Leakage current</td> <td>≤The initial specified value</td> </tr> </table>	Appearance	No significant damage	Capacitance change	≤±20% of the initial value	D.F. (tanδ)	≤150% of the initial specified value	ESR	≤150% of the initial specified value	Leakage current	≤The initial specified value
Appearance	No significant damage										
Capacitance change	≤±20% of the initial value										
D.F. (tanδ)	≤150% of the initial specified value										
ESR	≤150% of the initial specified value										
Leakage current	≤The initial specified value										
Bias Humidity Test	The following specifications shall be satisfied when the capacitors are restored to 20°C after subjecting them to DC voltage at 60°C, 90 to 95% RH for 1,000 hours.										
	<table border="1"> <tr> <td>Appearance</td> <td>No significant damage</td> </tr> <tr> <td>Capacitance change</td> <td>≤±20% of the initial value</td> </tr> <tr> <td>D.F. (tanδ)</td> <td>≤150% of the initial specified value</td> </tr> <tr> <td>ESR</td> <td>≤150% of the initial specified value</td> </tr> <tr> <td>Leakage current</td> <td>≤The initial specified value</td> </tr> </table>	Appearance	No significant damage	Capacitance change	≤±20% of the initial value	D.F. (tanδ)	≤150% of the initial specified value	ESR	≤150% of the initial specified value	Leakage current	≤The initial specified value
Appearance	No significant damage										
Capacitance change	≤±20% of the initial value										
D.F. (tanδ)	≤150% of the initial specified value										
ESR	≤150% of the initial specified value										
Leakage current	≤The initial specified value										
Surge Voltage Test	The capacitors shall be subjected to 1,000 cycles each consisting of charge with the surge voltage specified at 105°C for 30 seconds through a protective resistor(R=1kΩ) and discharge for 5 minutes 30 seconds.										
	<table border="1"> <tr> <td>Appearance</td> <td>No significant damage</td> </tr> <tr> <td>Capacitance change</td> <td>≤±20% of the initial value</td> </tr> <tr> <td>D.F. (tanδ)</td> <td>≤150% of the initial specified value</td> </tr> <tr> <td>ESR</td> <td>≤150% of the initial specified value</td> </tr> <tr> <td>Leakage current</td> <td>≤The initial specified value</td> </tr> </table>	Appearance	No significant damage	Capacitance change	≤±20% of the initial value	D.F. (tanδ)	≤150% of the initial specified value	ESR	≤150% of the initial specified value	Leakage current	≤The initial specified value
Appearance	No significant damage										
Capacitance change	≤±20% of the initial value										
D.F. (tanδ)	≤150% of the initial specified value										
ESR	≤150% of the initial specified value										
Leakage current	≤The initial specified value										
Failure Rate	0.5% per 1,000 hours maximum (Confidence level 60% at 105°C)										

*Note : If any doubt arises, measure the leakage current after the following voltage treatment.
Voltage treatment : DC rated voltage is applied to the capacitors for 120 minutes at 105°C.

◆ DIMENSIONS [mm]

- Terminal Code : E

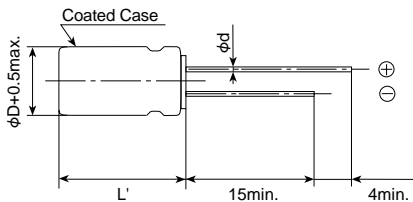

φD	6.3	8	10
φd	0.5	0.8	
F	2.5	3.5	5.0
φD'	φD+0.5max		
L'	L+0.3max	L+1.5max	

◆ MARKING

EX) 4V560μF



NPCAP™-PSA Series

◆PART NUMBERING SYSTEM

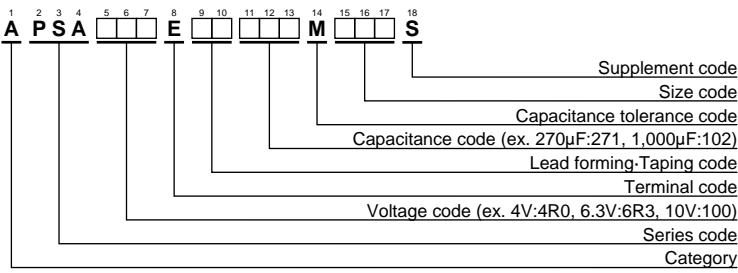

Please refer to "Product code guide (conductive polymer type)"

◆STANDARD RATINGS

WV(Vdc)	Cap(μF)	Case size φD×L(mm)	ESR (mΩmax/20°C, 100k to 300kHz)	Rated ripple current (mArms/105°C, 100kHz)	Part No.
2.5	390	6.3×10.5	20	3,160	APSA2R5E□□391MFA5S
	680	8×11.5	7	5,580	APSA2R5E□□681MHB5S
	820	8×11.5	7	5,580	APSA2R5E□□821MHB5S
	1,000	10×11.5	6	5,860	APSA2R5E□□102MJB5S
	1,500	10×11.5	7	5,860	APSA2R5E□□152MJB5S
4	270	6.3×10.5	20	3,160	APSA4R0E□□271MFA5S
	390	6.3×10.5	24	3,300	APSA4R0E□□391MFA5S
	560	8×11.5	7	5,580	APSA4R0E□□561MHB5S
	820	10×11.5	6	5,860	APSA4R0E□□821MJB5S
6.3	220	6.3×10.5	20	3,160	APSA6R3E□□221MFA5S
	330	6.3×10.5	28	3,190	APSA6R3E□□331MFA5S
	390	8×11.5	8	5,080	APSA6R3E□□391MHB5S
	470	8×11.5	7	5,700	APSA6R3E□□471MHB5S
	680	10×11.5	7	5,860	APSA6R3E□□681MJB5S
10	47	6.3×10.5	25	2,820	APSA100E□□470MFA5S
	68	6.3×10.5	25	2,820	APSA100E□□680MFA5S
	100	6.3×10.5	25	2,820	APSA100E□□101MFA5S
	150	6.3×10.5	25	2,820	APSA100E□□151MFA5S
	270	8×11.5	9	4,710	APSA100E□□271MHB5S
	470	10×11.5	8	5,650	APSA100E□□471MJB5S
16	100	6.3×10.5	25	2,820	APSA160E□□101MFA5S

□□ : Enter the appropriate lead forming or taping code.

NPCAP™-PS Series

- Super low ESR, high temperature resistance
- Large capacitance & Improved high ripple current capability
- Rated voltage range : 2.5 to 35V_{dc}
- Endurance : 2,000 hours at 105°C
- Suitable for DC-DC converters, voltage regulators and decoupling applications
For computer motherboards
- RoHS Compliant

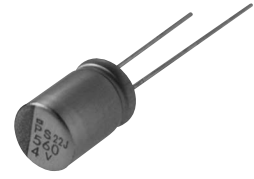
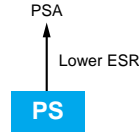

◆ SPECIFICATIONS

Items	Characteristics
Category Temperature Range	-55 to +105°C
Rated Voltage Range	2.5 to 35V _{dc}
Capacitance Tolerance	±20% (M) (at 20°C, 120Hz)
Surge Voltage	Rated voltage×1.15 (at 105°C)
Leakage Current *Note	I=0.2CV (Rated voltage 2.5 to 25V _{dc}) / I=0.5CV (Rated voltage 35V _{dc}) Where, I : Max. leakage current (μA), C : Nominal capacitance (μF), V : Rated voltage (V _{dc}) (at 20°C after 2 minutes)
Dissipation Factor (tanδ)	0.12 max. (at 20°C, 120Hz)
Low Temperature Characteristics (Max. Impedance Ratio)	Z(-25°C)/Z(+20°C)≤1.15 Z(-55°C)/Z(+20°C)≤1.25 (at 100kHz)
Endurance	The following specifications shall be satisfied when the capacitors are restored to 20°C after the rated voltage is applied for 2,000 hours at 105°C.
Appearance	No significant damage
Capacitance change	≤±20% of the initial value
D.F. (tanδ)	≤150% of the initial specified value
ESR	≤150% of the initial specified value
Leakage current	≤The initial specified value
Bias Humidity Test	The following specifications shall be satisfied when the capacitors are restored to 20°C after subjecting them to DC voltage at 60°C, 90 to 95% RH for 1,000 hours.
Appearance	No significant damage
Capacitance change	≤±20% of the initial value
D.F. (tanδ)	≤150% of the initial specified value
ESR	≤150% of the initial specified value
Leakage current	≤The initial specified value
Surge Voltage Test	The capacitors shall be subjected to 1,000 cycles each consisting of charge with the surge voltage specified at 105°C for 30 seconds through a protective resistor(R=1kΩ) and discharge for 5 minutes 30 seconds.
Appearance	No significant damage
Capacitance change	≤±20% of the initial value
D.F. (tanδ)	≤150% of the initial specified value
ESR	≤150% of the initial specified value
Leakage current	≤The initial specified value
Failure Rate	0.5% per 1,000 hours maximum (Confidence level 60% at 105°C)

*Note : If any doubt arises, measure the leakage current after the following voltage treatment.
Voltage treatment : DC rated voltage is applied to the capacitors for 120 minutes at 105°C.

◆ DIMENSIONS [mm]

- Terminal Code : E

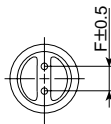
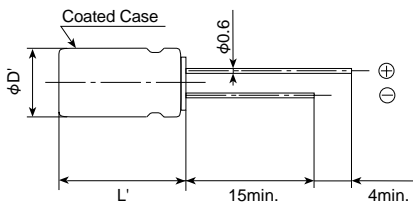

φD	8	10
φd	0.6	
F	3.5	5.0
φD'	φD+0.5max.	
L'	L+1.5max.	

◆ MARKING

EX) 4V820μF



◆PART NUMBERING SYSTEM

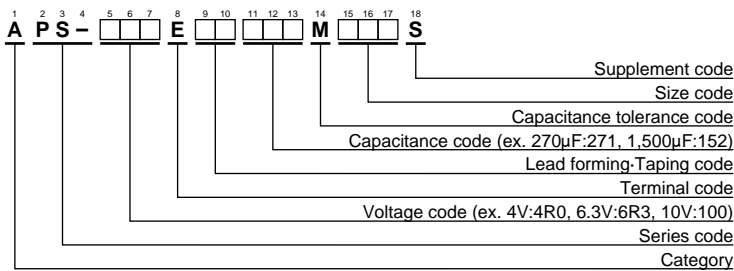

Please refer to "Product code guide (conductive polymer type)"

◆STANDARD RATINGS

WV(Vdc)	Cap(µF)	Case size φD×L(mm)	ESR (mΩmax/20°C, 100k to 300kHz)	Rated ripple current (mArms/105°C, 100kHz)	Part No.
2.5	680	8 × 11.5	10	5,230	APS-2R5E□□681MHB5S
	820	8 × 11.5	10	5,230	APS-2R5E□□821MHB5S
	1500	10 × 12.5	8	5,500	APS-2R5E□□152MJC5S
4	560	8 × 11.5	10	5,230	APS-4R0E□□561MHB5S
	820	10 × 12.5	8	5,500	APS-4R0E□□821MJC5S
	1000	10 × 12.5	8	5,500	APS-4R0E□□102MJC5S
	1200	10 × 12.5	8	5,500	APS-4R0E□□122MJC5S
6.3	390	8 × 11.5	12	4,770	APS-6R3E□□391MHB5S
	470	8 × 11.5	12	4,770	APS-6R3E□□471MHB5S
	680	10 × 12.5	10	5,500	APS-6R3E□□681MJC5S
	820	10 × 12.5	10	5,500	APS-6R3E□□821MJC5S
	1000	10 × 12.5	10	5,500	APS-6R3E□□102MJC5S
10	270	8 × 11.5	14	4,420	APS-100E□□271MHB5S
	330	8 × 11.5	14	4,420	APS-100E□□331MHB5S
	470	10 × 12.5	12	5,300	APS-100E□□471MJC5S
	560	10 × 12.5	12	5,300	APS-100E□□561MJC5S
16	100	8 × 11.5	16	4,360	APS-160E□□101MHB5S
	180	8 × 11.5	16	4,360	APS-160E□□181MHB5S
	270	10 × 12.5	14	5,050	APS-160E□□271MJC5S
	330	10 × 12.5	14	5,050	APS-160E□□331MJC5S
20	100	8 × 11.5	24	3,320	APS-200E□□101MHB5S
	150	10 × 12.5	20	4,320	APS-200E□□151MJC5S
25	68	8 × 11.5	24	3,320	APS-250E□□680MHB5S
	100	10 × 12.5	20	4,320	APS-250E□□101MJC5S
35	18	8 × 11.5	34	2,830	APS-350E□□180MHB5S
	33	10 × 12.5	30	3,270	APS-350E□□330MJC5S

□□ : Enter the appropriate lead forming or taping code.

MVL Series

MVH Series

●105°C Endurance

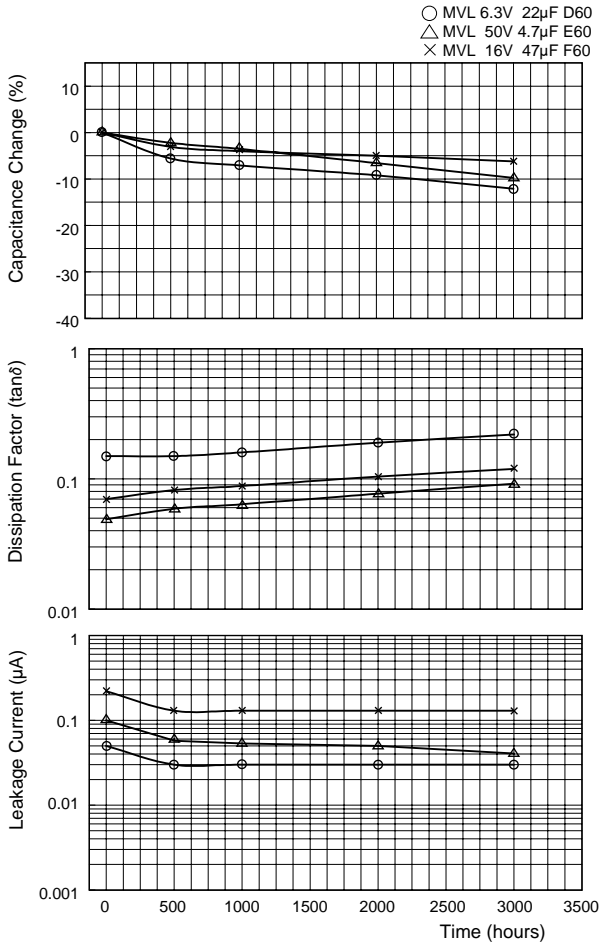

●125°C Endurance

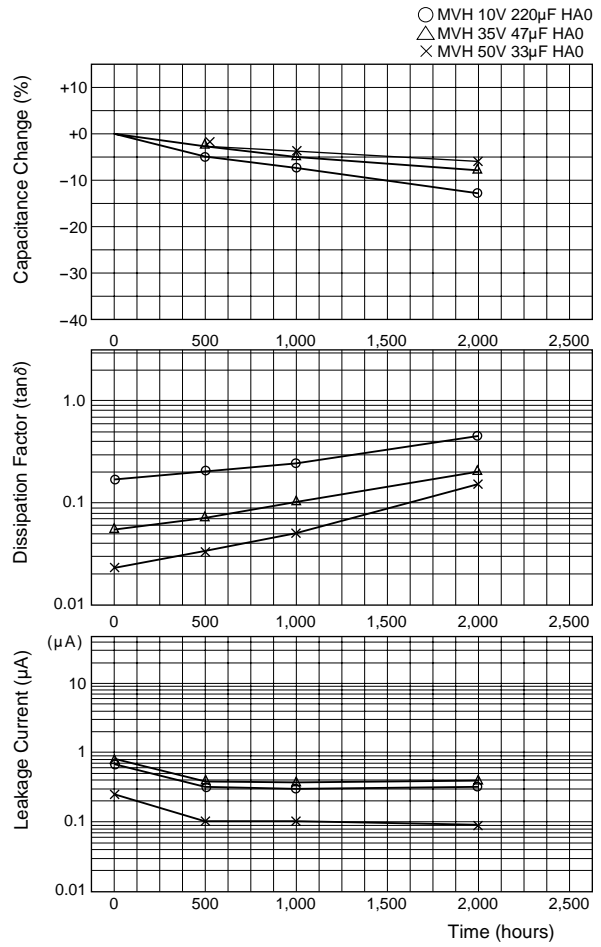

MVY Series

●Impedance/ESR vs Frequency

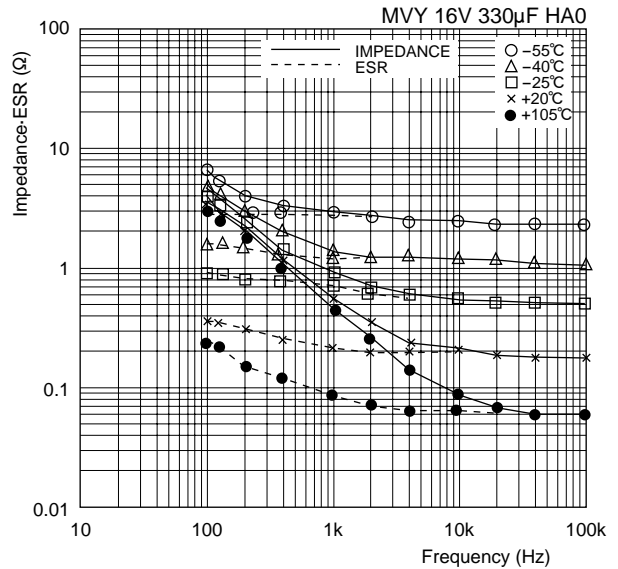
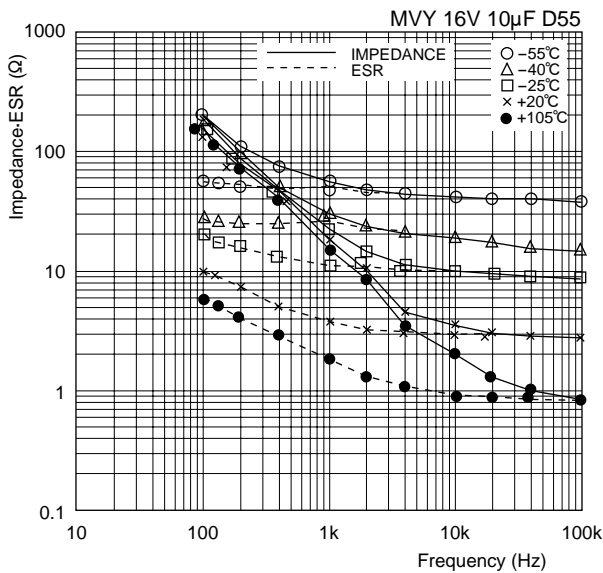

●105°C Endurance with Rated Ripple Current

○KZE 10V 220μF φ6.3×11L
 △KZE 16V 680μF φ10×16L
 □KZE 50V 470μF φ12.5×20L

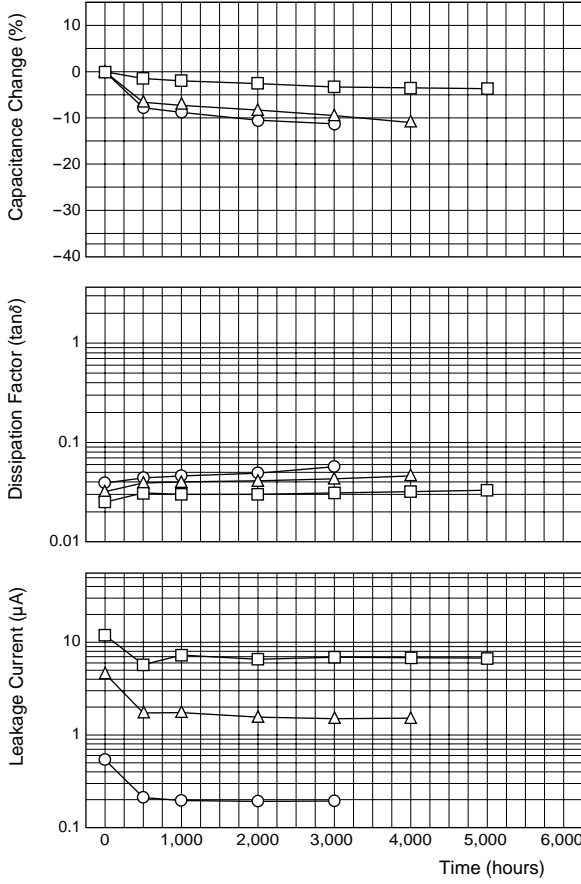

●105°C Shelf Life

○KZE 10V 220μF φ6.3×11L
 △KZE 16V 680μF φ10×16L
 □KZE 50V 470μF φ12.5×20L

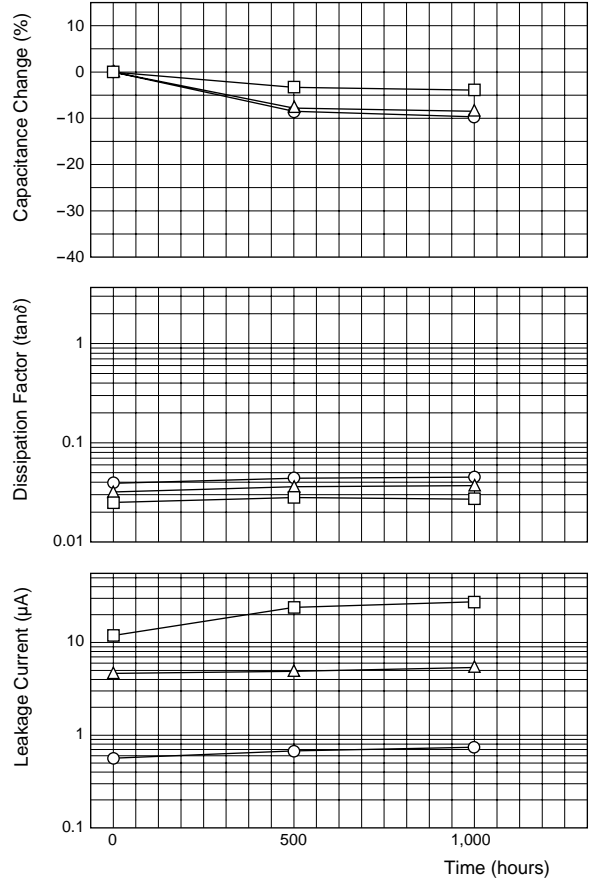

●Impedance-Frequency Characteristics

○KZE 10V 220μF φ6.3×11L
 △KZE 16V 680μF φ10×16L
 □KZE 50V 470μF φ12.5×20L at 20°C

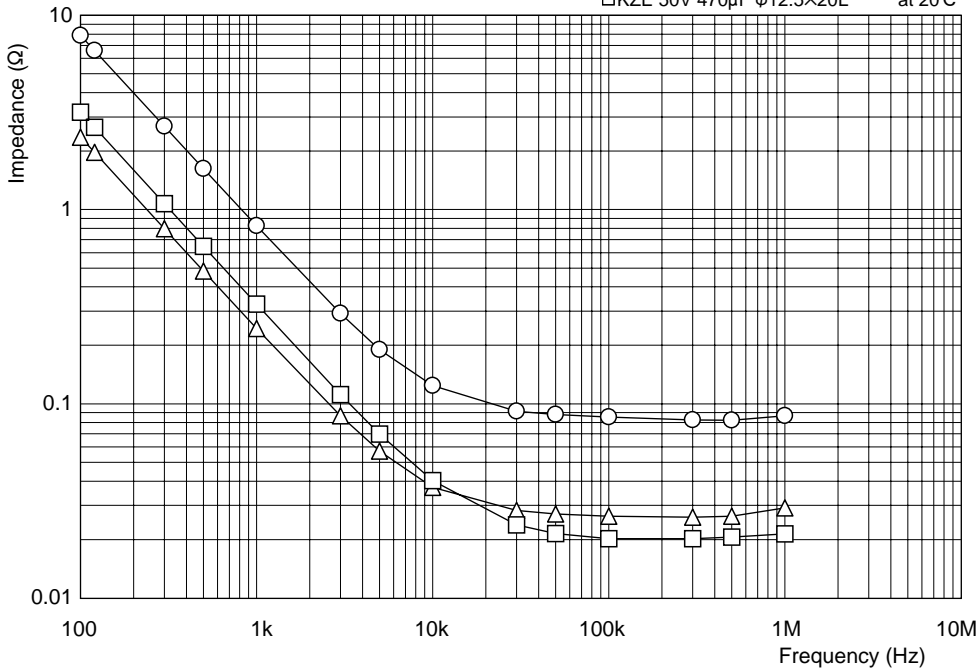

LXZ Series

LXY Series

●105°C Endurance with Rated Ripple Current

●105°C Endurance with Rated Ripple Current

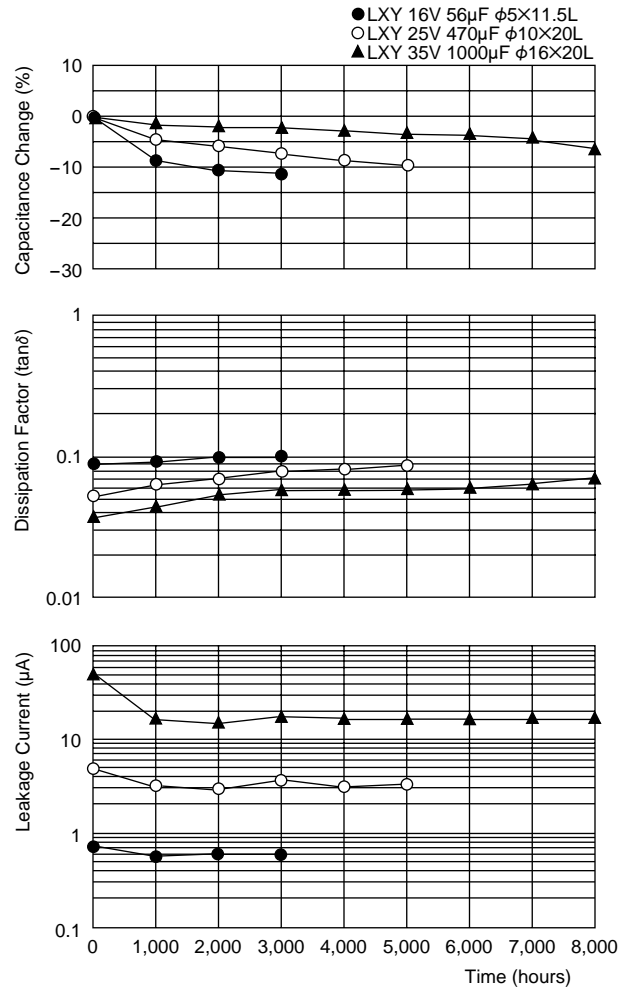
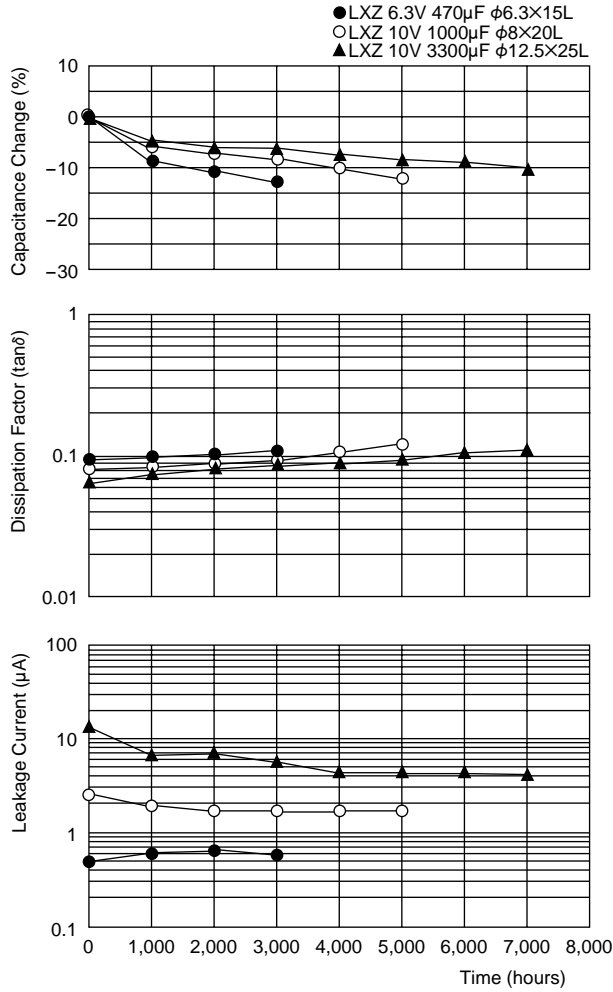

●Impedance-Frequency Characteristics

●Impedance-Frequency Characteristics

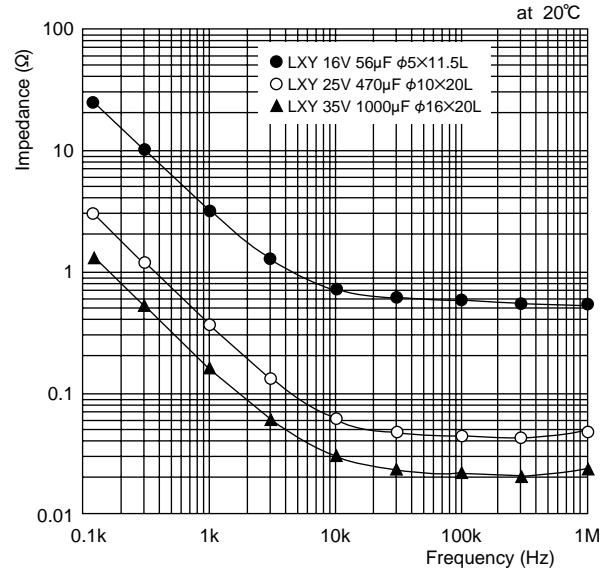
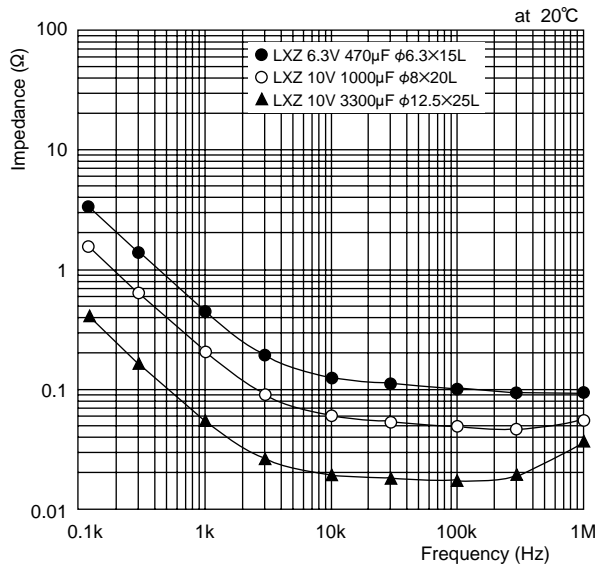

●105°C Endurance with Rated Ripple Current

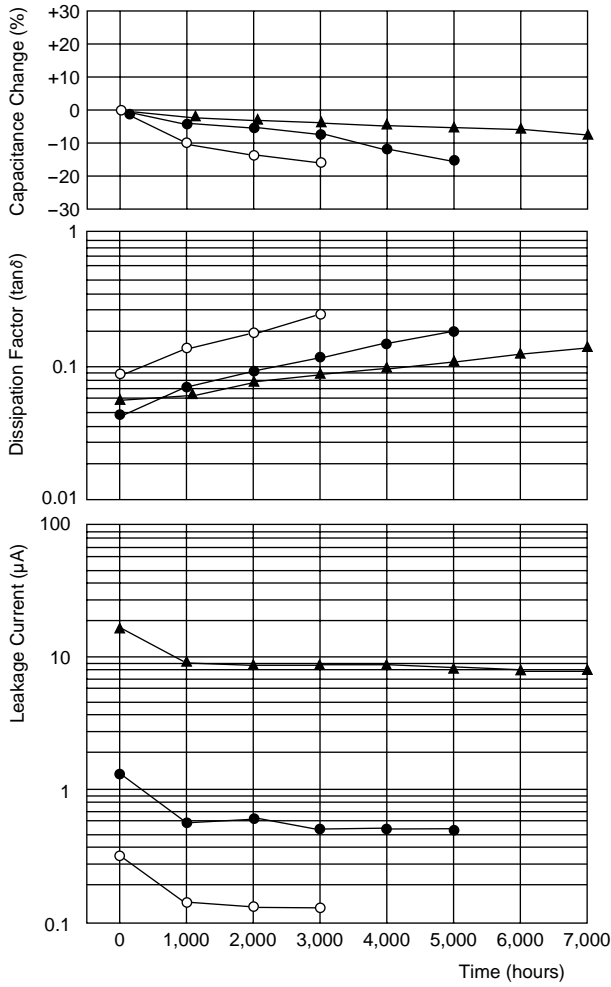

●105°C Shelf Life test

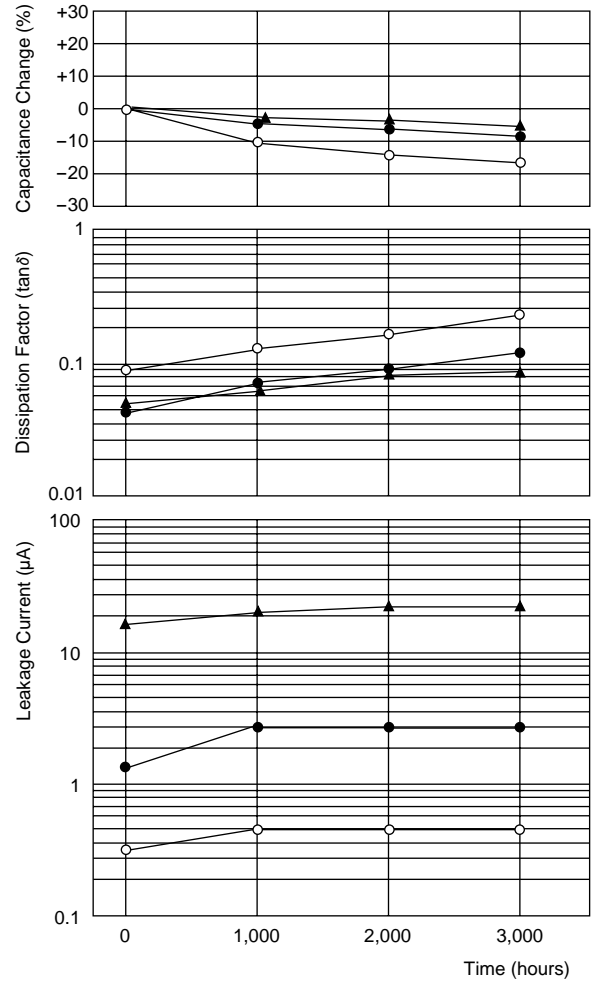

●Temperature Characteristics

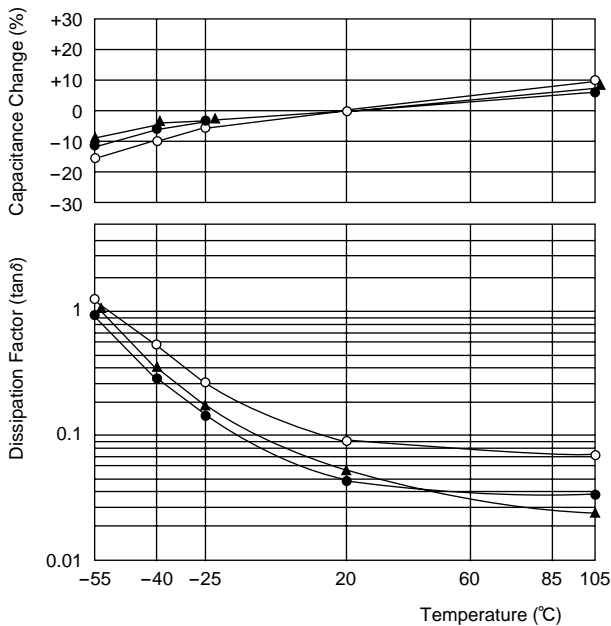

●Impedance-Frequency Characteristics

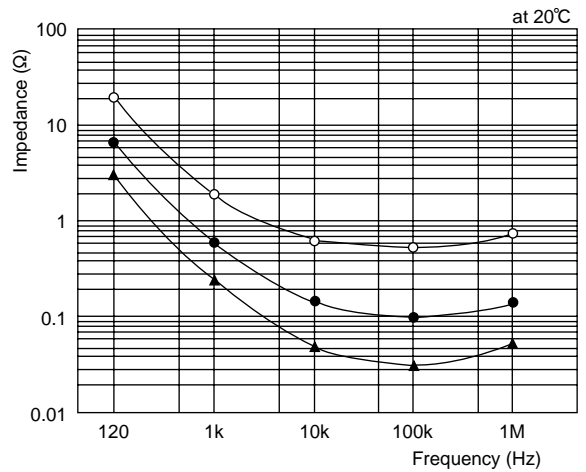

●125°C Endurance with Rated Ripple Current

- GXE 35V 100μF φ8×12L
- △ GXE 50V 100μF φ10×12.5L
- GXE 10V 3300μF φ16×25L

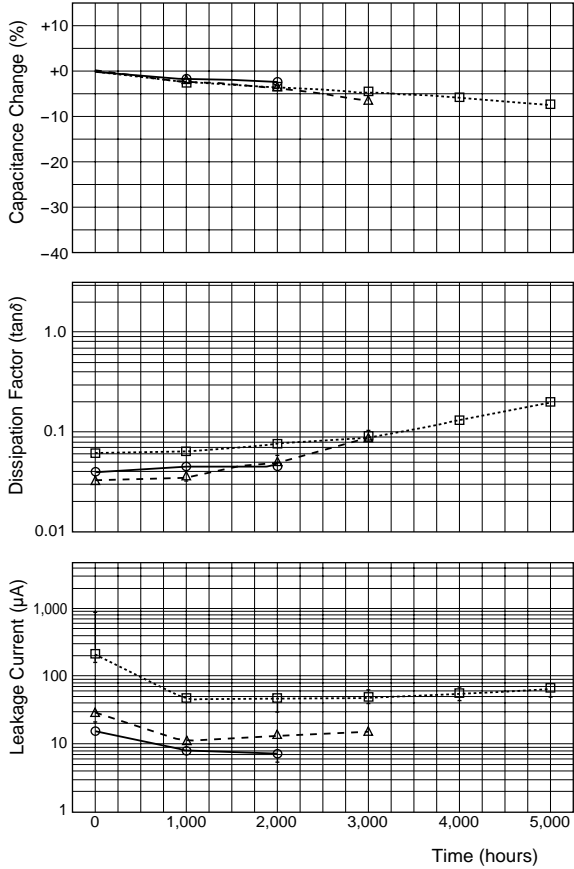

●Impedance-Frequency Characteristics

- GXE 35V 100μF φ8×12L
- △ GXE 50V 100μF φ10×12.5L
- GXE 10V 3300μF φ16×25L at 20°C

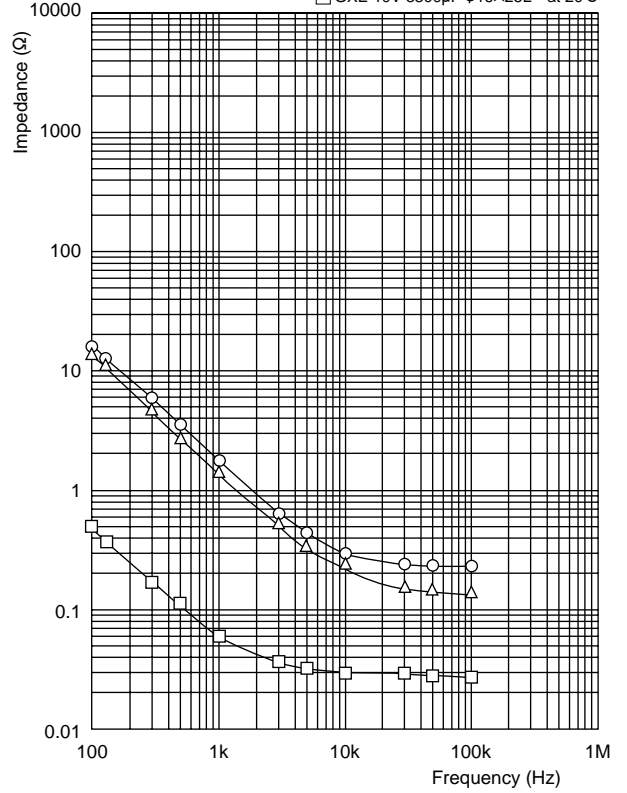

SMM Series

●85°C Endurance with Rated Ripple Current

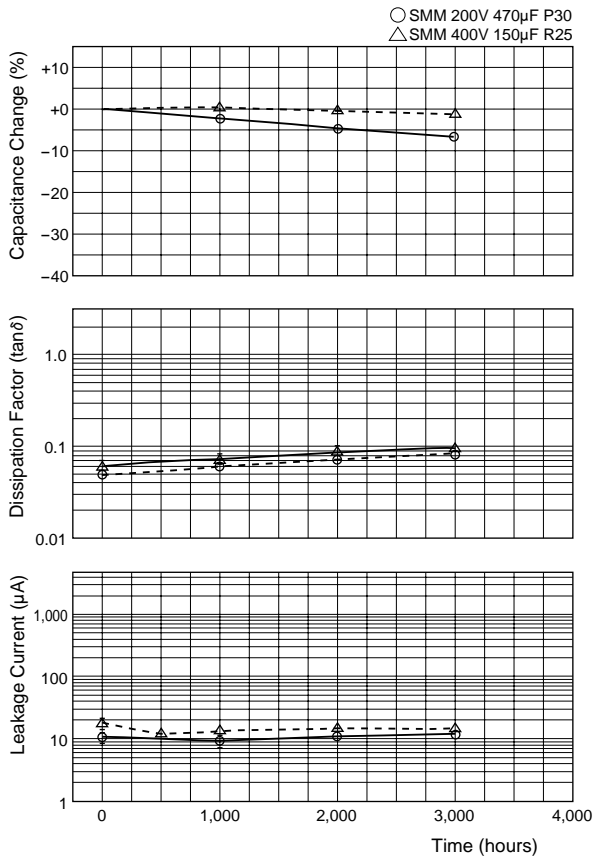

KMM Series

●105°C Endurance with Rated Ripple Current

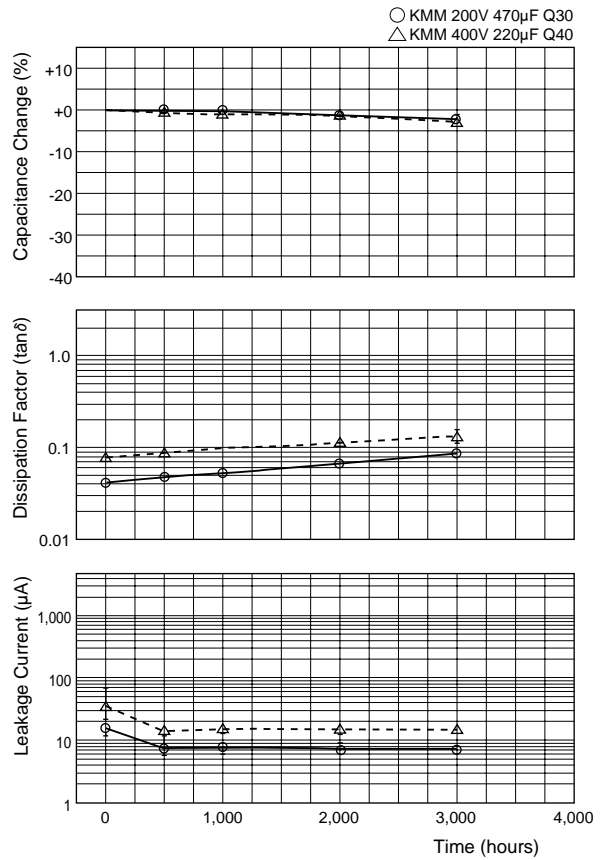

LXG Series

●105°C Endurance with Rated Ripple Current

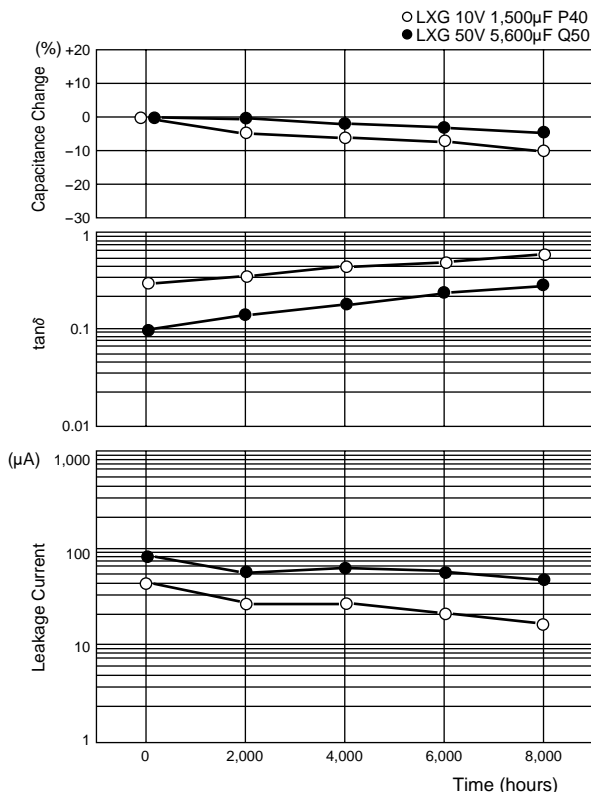

LXH Series

●105°C Endurance with Rated Ripple Current

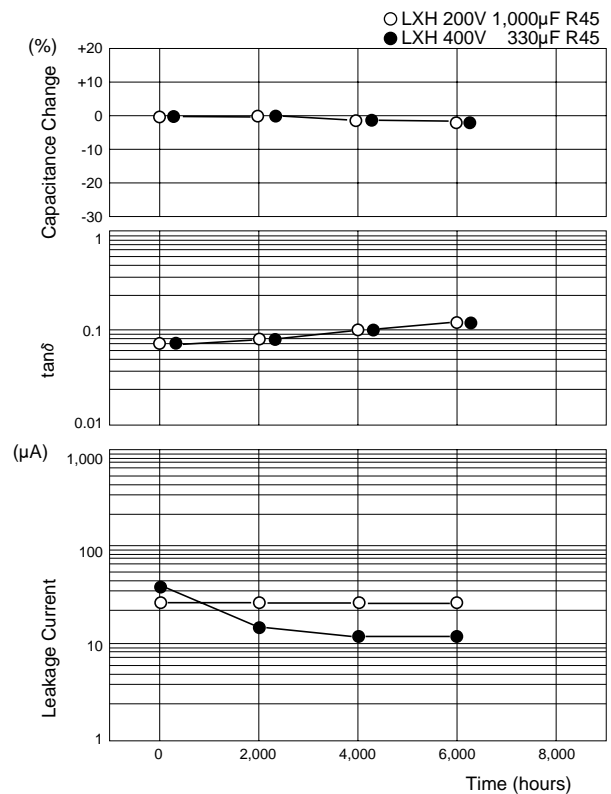

RWE/RWF/RWL Series

RWE/RWF series

●85°C Endurance with Rated Ripple Current

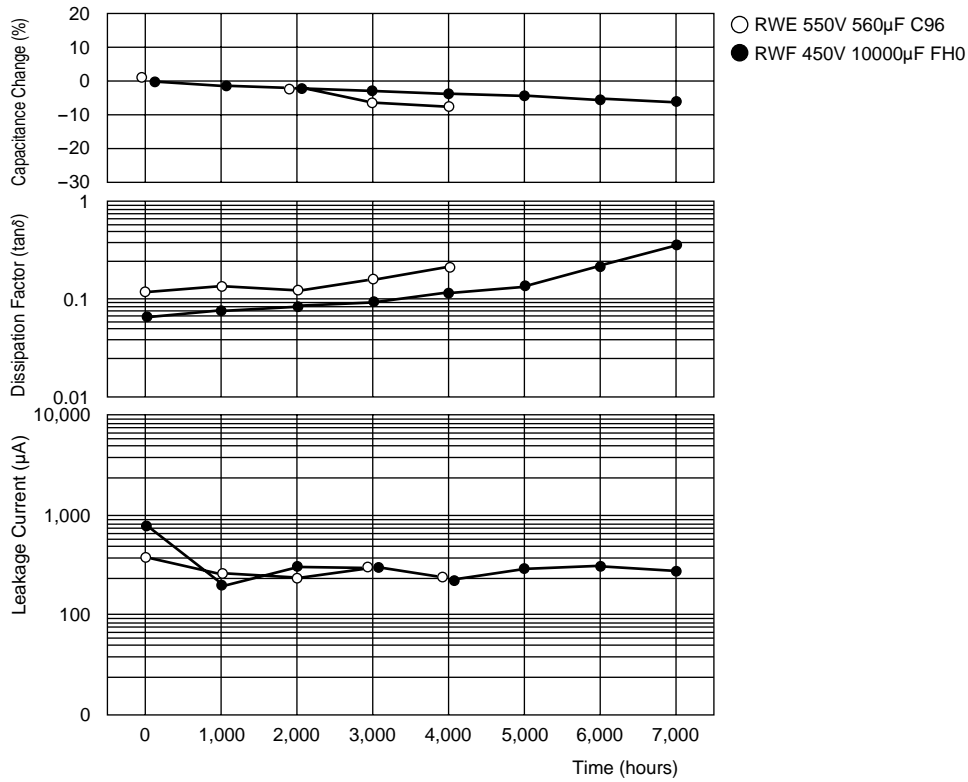

RWL series

●85°C Endurance with Rated Ripple Current

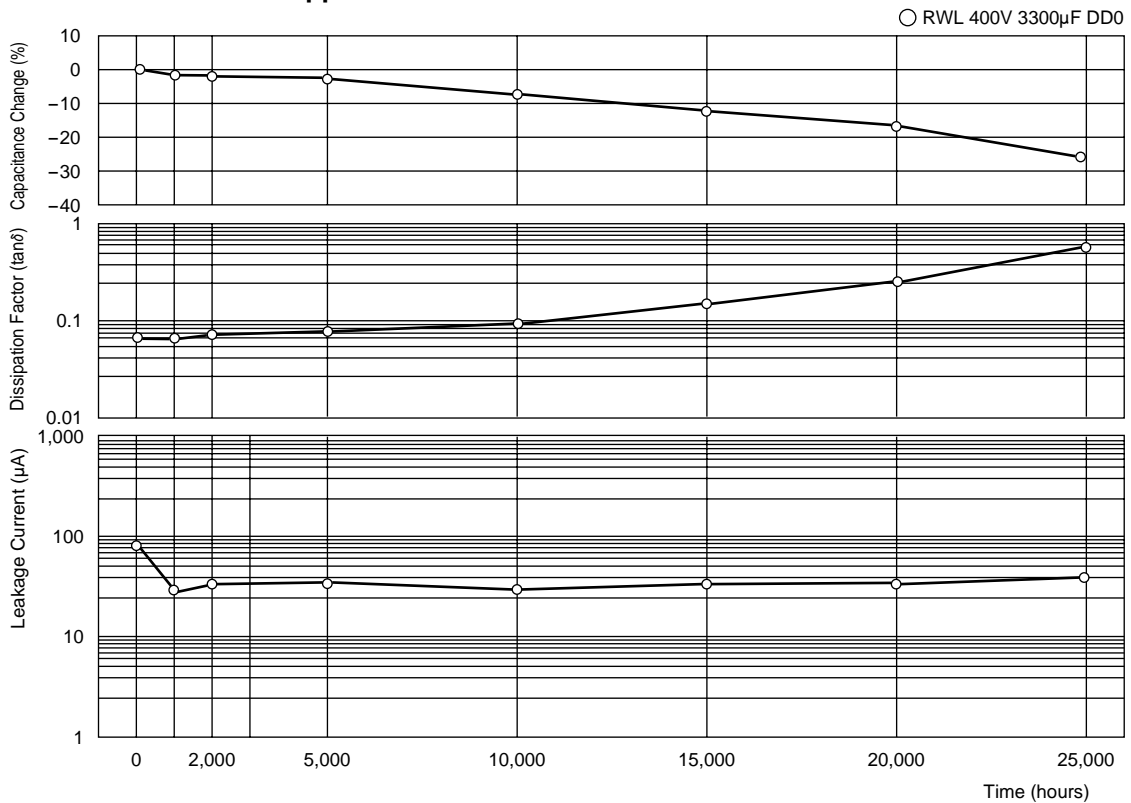

Appendix (Part number)

◆Capacitance code

* How to use the table

	1st
2nd	Cap. Value

Capacitance value part

2nd	1st								
	1	2	3	4	5	6	7	8	9
0	10.0	20.0	30.0	40.0	50.0	60.0	70.0	80.0	90.0
A	10.5	20.5	30.5	40.5	50.5	60.5	70.5	80.5	90.5
1	11.0	21.0	31.0	41.0	51.0	61.0	71.0	81.0	91.0
B	11.5	21.5	31.5	41.5	51.5	61.5	71.5	81.5	91.5
2	12.0	22.0	32.0	42.0	52.0	62.0	72.0	82.0	92.0
C	12.5	22.5	32.5	42.5	52.5	62.5	72.5	82.5	92.5
3	13.0	23.0	33.0	43.0	53.0	63.0	73.0	83.0	93.0
D	13.5	23.5	33.5	43.5	53.5	63.5	73.5	83.5	93.5
4	14.0	24.0	34.0	44.0	54.0	64.0	74.0	84.0	94.0
E	14.5	24.5	34.5	44.5	54.5	64.5	74.5	84.5	94.5
5	15.0	25.0	35.0	45.0	55.0	65.0	75.0	85.0	95.0
F	15.5	25.5	35.5	45.5	55.5	65.5	75.5	85.5	95.5
6	16.0	26.0	36.0	46.0	56.0	66.0	76.0	86.0	96.0
G	16.5	26.5	36.5	46.5	56.5	66.5	76.5	86.5	96.5
7	17.0	27.0	37.0	47.0	57.0	67.0	77.0	87.0	97.0
H	17.5	27.5	37.5	47.5	57.5	67.5	77.5	87.5	97.5
8	18.0	28.0	38.0	48.0	58.0	68.0	78.0	88.0	98.0
J	18.5	28.5	38.5	48.5	58.5	68.5	78.5	88.5	98.5
9	19.0	29.0	39.0	49.0	59.0	69.0	79.0	89.0	99.0
K	19.5	29.5	39.5	49.5	59.5	69.5	79.5	89.5	99.5

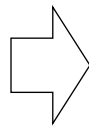

For less than 10 μ F, a decimal point position is displayed with R.

For 10 μ F or more, capacitance code is set to the first 2 digits and index (1digit).

Treatment of fraction (Refer to the table)

Example of conversion

Real cap.	The first 2 digits	Treatment of fraction	Code		
			11th	12th	13th
10.0 μ F →	10.0 →	10.0 →	1	0	0
10.1 μ F →	10.1 →	10.0 →	1	0	0
10.2 μ F →	10.2 →	10.0 →	1	0	0
10.3 μ F →	10.3 →	10.5 →	1	A	0
10.4 μ F →	10.4 →	10.5 →	1	A	0
10.5 μ F →	10.5 →	10.5 →	1	A	0
10.6 μ F →	10.6 →	10.5 →	1	A	0
10.7 μ F →	10.7 →	10.5 →	1	A	0
10.8 μ F →	10.8 →	11.0 →	1	1	0
10.9 μ F →	10.9 →	11.0 →	1	1	0
11.0 μ F →	11.0 →	11.0 →	1	1	0
132 μ F →	13.2 →	13.0 →	1	3	1
133 μ F →	13.3 →	13.5 →	1	D	1
167 μ F →	16.7 →	16.5 →	1	G	1
168 μ F →	16.8 →	17.0 →	1	7	1
1110 μ F →	11.1 →	11.0 →	1	1	2
1340 μ F →	13.4 →	13.5 →	1	D	2
13200 μ F →	13.2 →	13.0 →	1	3	3
13600 μ F →	13.6 →	13.5 →	1	D	3
270000 μ F →	27.0 →	27.0 →	2	7	4

◆Case length (Radial lead type)

Case length [mm]	16th	17th	Case length [mm]	16th	17th	Case length [mm]	16th	17th	Case length [mm]	16th	17th	Case length [mm]	16th	17th	Case length [mm]	16th	17th
0.0	—	—	1.0	0	1	2.0	0	2	3.0	0	3	4.0	0	4	5.0	0	5
0.1	0	B	1.1	1	B	2.1	2	B	3.1	3	B	4.1	4	B	5.1	5	B
0.2	0	C	1.2	1	C	2.2	2	C	3.2	3	C	4.2	4	C	5.2	5	C
0.3	0	D	1.3	1	D	2.3	2	D	3.3	3	D	4.3	4	D	5.3	5	D
0.4	0	E	1.4	1	E	2.4	2	E	3.4	3	E	4.4	4	E	5.4	5	E
0.5	0	F	1.5	1	F	2.5	2	F	3.5	3	F	4.5	4	F	5.5	5	F
0.6	0	G	1.6	1	G	2.6	2	G	3.6	3	G	4.6	4	G	5.6	5	G
0.7	0	H	1.7	1	H	2.7	2	H	3.7	3	H	4.7	4	H	5.7	5	H
0.8	0	J	1.8	1	J	2.8	2	J	3.8	3	J	4.8	4	J	5.8	5	J
0.9	0	K	1.9	1	K	2.9	2	K	3.9	3	K	4.9	4	K	5.9	5	K
6.0	0	6	6.1	6	B	7.0	0	7	8.0	0	8	9.0	0	9	10.0	1	0
6.1	6	B	6.2	6	C	7.1	7	B	8.1	8	B	9.1	9	B	10.1	A	1
6.2	6	C	6.3	6	D	7.2	7	C	8.2	8	C	9.2	9	C	10.2	A	2
6.3	6	D	6.4	6	E	7.3	7	D	8.3	8	D	9.3	9	D	10.3	A	3
6.4	6	E	6.5	6	F	7.4	7	E	8.4	8	E	9.4	9	E	10.4	A	4
6.5	6	F	6.6	6	G	7.5	7	F	8.5	8	F	9.5	9	F	10.5	A	5
6.6	6	G	6.7	6	H	7.6	7	G	8.6	8	G	9.6	9	G	10.6	A	6
6.7	6	H	6.8	6	J	7.7	7	H	8.7	8	H	9.7	9	H	10.7	A	7
6.8	6	J	6.9	6	K	7.8	7	J	8.8	8	J	9.8	9	J	10.8	A	8
6.9	6	K				7.9	7	K	8.9	8	K	9.9	9	K	10.9	A	9
11.0	1	1	11.1	B	1	12.0	1	2	13.0	1	3	14.0	1	4	15.0	1	5
11.1	B	1	11.2	B	2	12.1	C	1	13.1	D	1	14.1	E	1	16.0	2	6
11.2	B	2	11.3	B	3	12.2	C	2	13.2	D	2	14.2	E	2	16.1	3	7
11.3	B	3	11.4	B	4	12.3	C	3	13.3	D	3	14.3	E	3	16.2	4	8
11.4	B	4	11.5	B	5	12.4	C	4	13.4	D	4	14.4	E	4	16.3	5	9
11.5	B	5	11.6	B	6	12.5	C	5	13.5	D	5	14.5	E	5	16.4	6	0
11.6	B	6	11.7	B	7	12.6	C	6	13.6	D	6	14.6	E	6	16.5	7	1
11.7	B	7	11.8	B	8	12.7	C	7	13.7	D	7	14.7	E	7	16.6	8	2
11.8	B	8	11.9	B	9	12.8	C	8	13.8	D	8	14.8	E	8	16.7	9	3
11.9	B	9				12.9	C	9	13.9	D	9	14.9	E	9	16.8	0	4



PART NUMBERING SYSTEM

Case length [mm]	16th	17th
15.0	1	5
15.1	F	1
15.2	F	2
15.3	F	3
15.4	F	4
15.5	F	5
15.6	F	6
15.7	F	7
15.8	F	8
15.9	F	9

Case length [mm]	16th	17th
16.0	1	6
16.1	G	1
16.2	G	2
16.3	G	3
16.4	G	4
16.5	G	5
16.6	G	6
16.7	G	7
16.8	G	8
16.9	G	9

Case length [mm]	16th	17th
17.0	1	7
17.1	H	1
17.2	H	2
17.3	H	3
17.4	H	4
17.5	H	5
17.6	H	6
17.7	H	7
17.8	H	8
17.9	H	9

Case length [mm]	16th	17th
18.0	1	8
18.1	J	1
18.2	J	2
18.3	J	3
18.4	J	4
18.5	J	5
18.6	J	6
18.7	J	7
18.8	J	8
18.9	J	9

Case length [mm]	16th	17th
19.0	1	9
19.1	K	1
19.2	K	2
19.3	K	3
19.4	K	4
19.5	K	5
19.6	K	6
19.7	K	7
19.8	K	8
19.9	K	9

Case length [mm]	16th	17th
20.0	2	0
20.5	L	1
21.0	2	1
21.5	L	3
22.0	2	2
22.5	L	5
23.0	2	3
23.5	L	7
24.0	2	4
24.5	L	9
25.0	2	5
25.5	M	1
26.0	2	6
26.5	M	3
27.0	2	7
27.5	M	5
28.0	2	8
28.5	M	7
29.0	2	9
29.5	M	9

Case length [mm]	16th	17th
30.0	3	0
30.5	N	1
31.0	3	1
31.5	N	3
32.0	3	2
32.5	N	5
33.0	3	3
33.5	N	7
34.0	3	4
34.5	N	9
35.0	3	5
35.5	P	1
36.0	3	6
36.5	P	3
37.0	3	7
37.5	P	5
38.0	3	8
38.5	P	7
39.0	3	9
39.5	P	9

Case length [mm]	16th	17th
40.0	4	0
40.5	Q	1
41.0	4	1
41.5	Q	3
42.0	4	2
42.5	Q	5
43.0	4	3
43.5	Q	7
44.0	4	4
44.5	Q	9
45.0	4	5
45.5	R	1
46.0	4	6
46.5	R	3
47.0	4	7
47.5	R	5
48.0	4	8
48.5	R	7
49.0	4	9
49.5	R	9

Case length [mm]	16th	17th
50.0	5	0
50.5	S	1
51.0	5	1
51.5	S	3
52.0	5	2
52.5	S	5
53.0	5	3
53.5	S	7
54.0	5	4
54.5	S	9
55.0	5	5
55.5	T	1
56.0	5	6
56.5	T	3
57.0	5	7
57.5	T	5
58.0	5	8
58.5	T	7
59.0	5	9
59.5	T	9

Case length [mm]	16th	17th
60.0	6	0
60.5	U	1
61.0	6	1
61.5	U	3
62.0	6	2
62.5	U	5
63.0	6	3
63.5	U	7
64.0	6	4
64.5	U	9
65.0	6	5
65.5	V	1
66.0	6	6
66.5	V	3
67.0	6	7
67.5	V	5
68.0	6	8
68.5	V	7
69.0	6	9
69.5	V	9

Case length [mm]	16th	17th
70.0	7	0
70.5	W	1
71.0	7	1
71.5	W	3
72.0	7	2
72.5	W	5
73.0	7	3
73.5	W	7
74.0	7	4
74.5	W	9
75.0	7	5
75.5	X	1
76.0	7	6
76.5	X	3
77.0	7	7
77.5	X	5
78.0	7	8
78.5	X	7
79.0	7	9
79.5	X	9

Case length [mm]	16th	17th
80.0	8	0
80.5	Y	1
81.0	8	1
81.5	Y	3
82.0	8	2
82.5	Y	5
83.0	8	3
83.5	Y	7
84.0	8	4
84.5	Y	9
85.0	8	5
85.5	Z	1
86.0	8	6
86.5	Z	3
87.0	8	7
87.5	Z	5
88.0	8	8
88.5	Z	7
89.0	8	9
89.5	Z	9

◆Case length (Snap-in type / Screw mount terminal type)

Case length [mm]	16th	17th	Case length [mm]	16th	17th	Case length [mm]	16th	17th	Case length [mm]	16th	17th	Case length [mm]	16th	17th
20	2	0	30	3	0	40	4	0	50	5	0	60	6	0
21	2	1	31	3	1	41	4	1	51	5	1	61	6	1
22	2	2	32	3	2	42	4	2	52	5	2	62	6	2
23	2	3	33	3	3	43	4	3	53	5	3	63	6	3
24	2	4	34	3	4	44	4	4	54	5	4	64	6	4
25	2	5	35	3	5	45	4	5	55	5	5	65	6	5
26	2	6	36	3	6	46	4	6	56	5	6	66	6	6
27	2	7	37	3	7	47	4	7	57	5	7	67	6	7
28	2	8	38	3	8	48	4	8	58	5	8	68	6	8
29	2	9	39	3	9	49	4	9	59	5	9	69	6	9
70	7	0	80	8	0	90	9	0	100	A	0	110	B	0
71	7	1	81	8	1	91	9	1	101	A	1	111	B	1
72	7	2	82	8	2	92	9	2	102	A	2	112	B	2
73	7	3	83	8	3	93	9	3	103	A	3	113	B	3
74	7	4	84	8	4	94	9	4	104	A	4	114	B	4
75	7	5	85	8	5	95	9	5	105	A	5	115	B	5
76	7	6	86	8	6	96	9	6	106	A	6	116	B	6
77	7	7	87	8	7	97	9	7	107	A	7	117	B	7
78	7	8	88	8	8	98	9	8	108	A	8	118	B	8
79	7	9	89	8	9	99	9	9	109	A	9	119	B	9
120	C	0	130	D	0	140	E	0	150	F	0	160	G	0
121	C	1	131	D	1	141	E	1	151	F	1	161	G	1
122	C	2	132	D	2	142	E	2	152	F	2	162	G	2
123	C	3	133	D	3	143	E	3	153	F	3	163	G	3
124	C	4	134	D	4	144	E	4	154	F	4	164	G	4
125	C	5	135	D	5	145	E	5	155	F	5	165	G	5
126	C	6	136	D	6	146	E	6	156	F	6	166	G	6
127	C	7	137	D	7	147	E	7	157	F	7	167	G	7
128	C	8	138	D	8	148	E	8	158	F	8	168	G	8
129	C	9	139	D	9	149	E	9	159	F	9	169	G	9
170	H	0	180	J	0	190	K	0	200	L	0	210	M	0
171	H	1	181	J	1	191	K	1	201	L	1	211	M	1
172	H	2	182	J	2	192	K	2	202	L	2	212	M	2
173	H	3	183	J	3	193	K	3	203	L	3	213	M	3
174	H	4	184	J	4	194	K	4	204	L	4	214	M	4
175	H	5	185	J	5	195	K	5	205	L	5	215	M	5
176	H	6	186	J	6	196	K	6	206	L	6	216	M	6
177	H	7	187	J	7	197	K	7	207	L	7	217	M	7
178	H	8	188	J	8	198	K	8	208	L	8	218	M	8
179	H	9	189	J	9	199	K	9	209	L	9	219	M	9
220	N	0	230	P	0	240	Q	0	250	R	0			
221	N	1	231	P	1	241	Q	1	251	R	1			
222	N	2	232	P	2	242	Q	2	252	R	2			
223	N	3	233	P	3	243	Q	3	253	R	3			
224	N	4	234	P	4	244	Q	4	254	R	4			
225	N	5	235	P	5	245	Q	5	255	R	5			
226	N	6	236	P	6	246	Q	6	256	R	6			
227	N	7	237	P	7	247	Q	7	257	R	7			
228	N	8	238	P	8	248	Q	8	258	R	8			
229	N	9	239	P	9	249	Q	9	259	R	9			

◆ Supplement code

Surface mount type / Conductive polymer (Include Radial lead type)

	Terminal plating material (Radial lead type)		
	Sn100%	Sn-Bi	Sn-Pb
Coating case	S	G	N

Radial lead type / Snap-in type

		Terminal plating material (Radial lead type)		
		Sn100%	Sn-Bi	Sn-Pb
Outer sleeve	PET	S	D	C
	Coating case	H	G	F
	Polyolefin	L	—	—
	Pb-free PVC	M	—	N
	PVC	B	A	N

* Pb-free snap-in type does not have a plastic disk.

We also produce Pb-free snap-in type with "Plastic disk, Pb-free PVC sleeve and Sn100% terminal plating".

In this case, supplement code (the 18th digit) is "T".

Screw mount terminal type

	Screw terminal
Pb-free PVC	M
Polyolefin	S
PET	C
PVC	N