

NJG1144KF1
(R&D code:J0191)
GPS Low Noise Amplifier

Target specification

- Target specification
- Pin configuration
- Application circuit
- Package outline

Written by Nobuhiro Izumiseki

Approved by Koji Hayashi

New Japan Radio Co., Ltd.

Design Section 1
MMIC Design Department
Microwave and Optoelectronic Device Division

■ TARGET SPECIFICATION

DC Characteristics

General condition : $V_{DD}=2.85/1.80V$, $T_a=25^{\circ}C$

Parameter	Symbol	Condition	Target Specification(Ver.2)						Units
			$V_{DD}=2.85V$			$V_{DD}=1.8V$			
			min.	typ.	max.	min.	typ.	max.	
Supply Voltage	V_{DD}		2.5	2.85	3.5	-	1.8	-	V
Operating Current	I_{DD}	RF OFF	-	3.5	5.5	-	1.8	-	mA

RF Characteristics

General condition : $V_{DD}=2.85/1.80V$, $T_a=25^{\circ}C$, $f_{RF}=1575MHz$, $Z_s=Z_l=50\Omega$, with application circuit

Parameter	Symbol	Condition	Target Specification(Ver.2)						Units
			$V_{DD}=2.85V$			$V_{DD}=1.8V$			
			min.	typ.	max.	min.	typ.	max.	
Small Signal Gain	Gain		19	22	25	-	19.5	-	dB
Noise Figure	NF	Exclude PCB, Connector Lossess	-	0.6	1.1	-	0.75	-	dB
Input Power 1dB Compression	P-1dB(IN)		-19.0	-16.5	-	-	-18.5	-	dBm
Input 3rd Order Intercept Point	IIP3	$f_1=f_{RF}$, $f_2=f_1+100kHz$, $P_{in}=-34dBm$	-9.0	-2.0	-	-	-6.0	-	dBm
RF IN VSWR	VSWR _i		-	1.5	2.3	-	2.0	-	-
RF OUT VSWR	VSWR _o		-	1.5	2.3	-	1.5	-	-

■ PIN COFIGURATION

KF1 Type
(Top View)

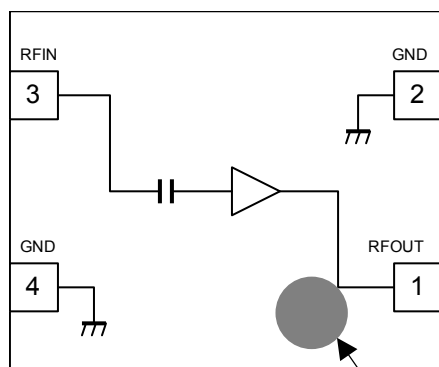

Pin connection

1. RFOUT
2. GND
3. RFIN
4. GND

1Pin INDEX

■ APPLICATION CIRCUIT

(Top View)

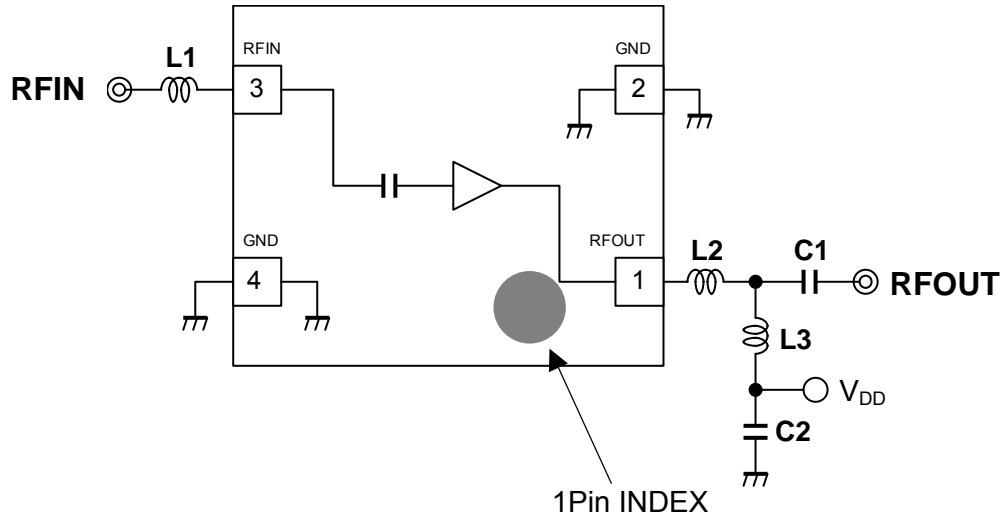

■ PACKAGE OUTLINE (ESON4-F1)

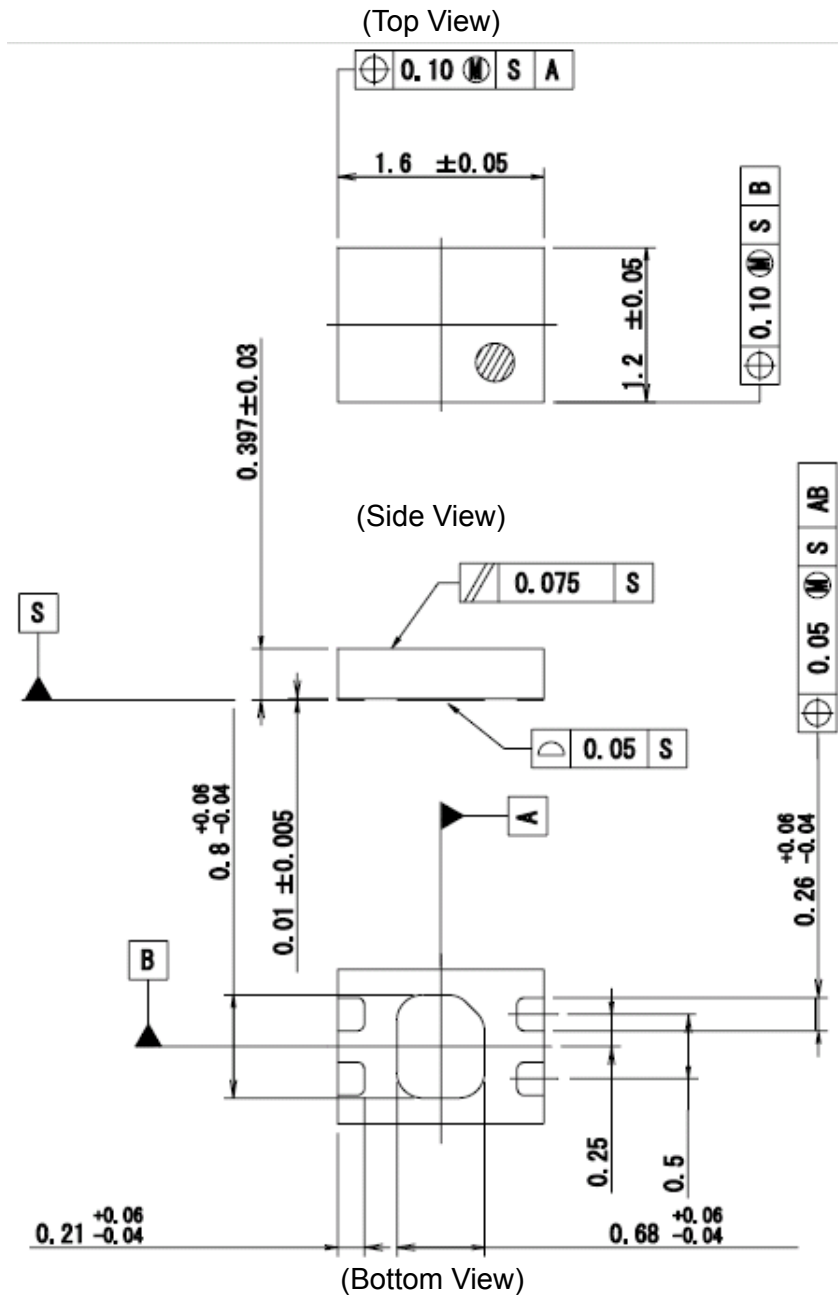

Units : mm
 Board : Cu
 Terminal treat : SnBi
 Molding material : Epoxy resin