

13 mm LASER TRACKBALL

X13

Utilizing the latest and most advanced laser tracking technology, the X13 laser Trackerball™ is an extremely high specification, contact-less device, ideal for the most demanding of cursor control applications.

The laser tracking engine provides accurate cursor motion at all speeds and on virtually any ball, combining the benefits of solid state sensing (no moving parts except the ball). The design incorporates a removable top ring as standard to allow for easy cleaning, decontamination, sterilisation and maintenance - ensuring continued optimum performance and operation under the harshest of conditions.

The X13 trackballs are available with a variety of electrical outputs, tracking force options, and sealing capabilities up to IP68.

The trackball has been designed to be back of panel mounted as part of OEM keyboards and consoles



- Solid state sensing technology
Laser tracking engine
- Sealing IP68
- Output: PS/2 & USB or Quadrature
- Smooth operation in rugged environments
- Various top plate configurations
- Custom connector options

SPECIFICATIONS

Mechanical

Weight	15 grams
Ball	Epoxy Resin, 12,7 mm
Tracking Force	10 grams Nominal - damper ring 10 - 30 grams - rubber seal
Ball Load	50N Maximum downward pressure (5 Kg) for 2 mins.
Resolvable Ball Speed	40 Inches/sec.
Housing Material	Polycarbonate (Lexan®LS2 lens grade) / ABS
Transducer	Optical Navigation Technology (solid state sensing)
Mounting Position	All angles (Dependant on top plate arrangement)

Electrical

Supply voltage	4.4V to 5.25V D.C.
Supply current	23mA typical, 25mA maximum
Resolution	300 counts per ball revolution @ 1 IPS (inches per second) +/- 10% 600 counts per ball revolution @ 5 IPS (inches per second) +/- 10%
Output connector	8 Way, right-angled JST film connector, part no: 08FM-1.0SP-1.9-TF
Laser safety class	Embedded class 1M laser safety, IEC 60825-1

Environmental

Operating temperature	0°C to +55°C (IEC 60068-2-1, IEC60068-2-2)
Storage temperature	-40°C to + 85°C (IEC 60068-2-1, IEC60068-2-2)
Operating humidity	93% RH @ 40°C, non-condensing (IEC 60068-2-78)
Storage humidity	10%-95% non-condensing (IEC 60068-2-78)
Vibration	5g, 10-500Hz, 1 octave/min, 10 sweep cycles (IEC 60068-2-6)
Operating Shock	15g/11ms, ½ sine, 3 shocks in +ve and -ve direction, all 3 axes (IEC 60068-2-27)
Mechanical lifetime	1 million ball revolutions
MTBF	in excess of 80,000 hours (MIL-STD-217F)
ESD	15kV air-discharge and 8kV contact discharge (IEC 61000-4-2)
EMC	Radiated immunity - limits according to level 3 of IEC 61000-4-3 Radiated emissions to EN55022 class B
Sealing capability	IP68 (BS EN 60529)

13 mm LASER TRACKBALL

DIMENSIONAL DRAWING

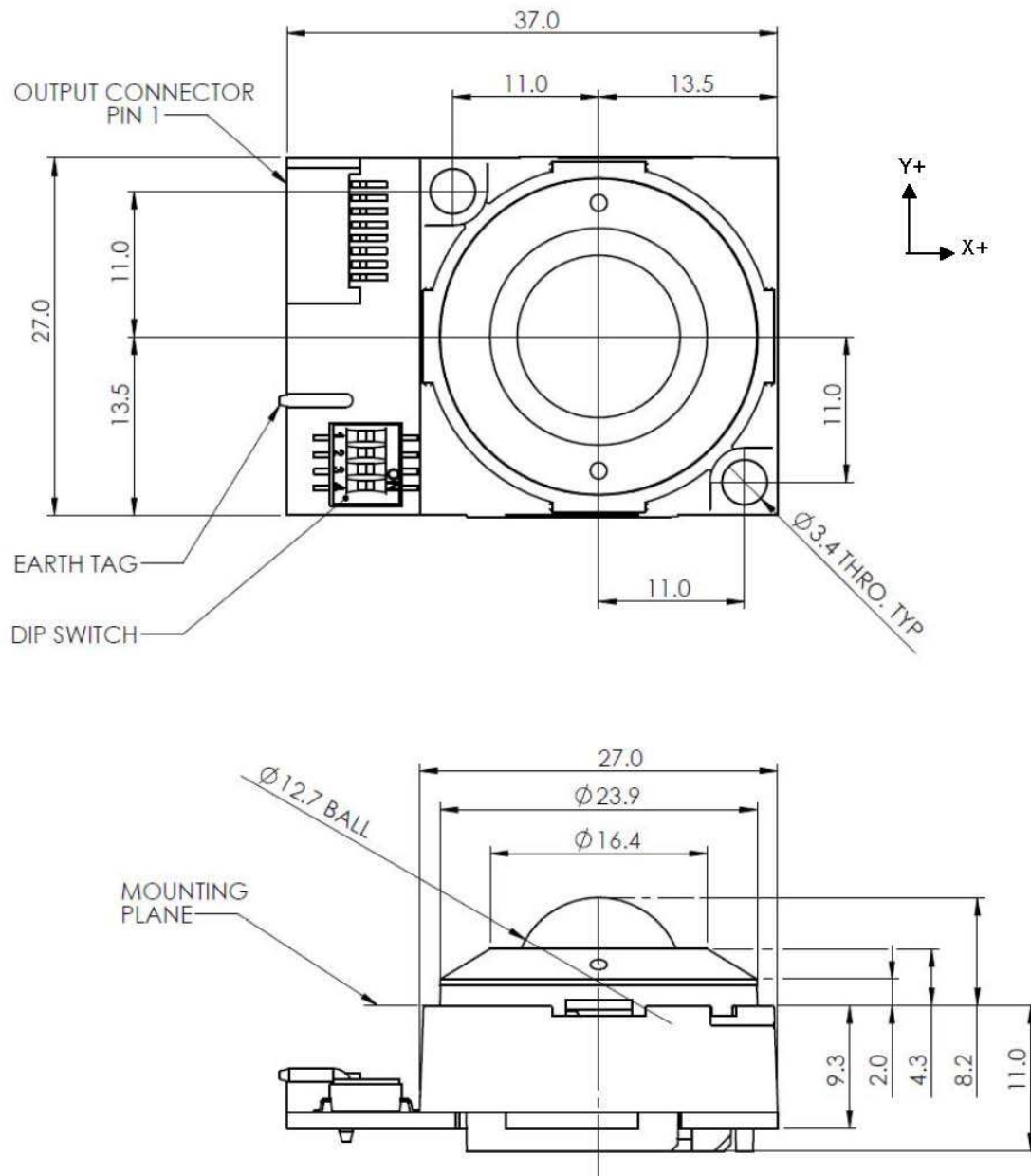

Dimensional drawing specifies factory default orientation.
 All dimensions are in mm unless otherwise stated.
 Tolerances +/- 0.2mm unless otherwise stated
 Please note that an IGES model is available on request.
 Please contact your local sales office for more information.

The company reserves the right to alter without prior knowledge the specification or design of any standard product or service.

13 mm LASER TRACKBALL

CONNECTION DETAILS QUADRATURE OUTPUT

Output Connector : P1

Description: header 8 way FM 1.0mm pitch
 Manufacturer: JST (or equivalent)
 Part No: 08FM-1.0SP-1.9-TF
 Mating connector: Flexible flat cable (FFC), 1.0mm pitch

Pin Number	Quadrature
1	+5V DC
2	X1
3	X2
4	Y1
5	Y2
6	0V
7	Not used
8	Not used

CONNECTION DETAILS PS/2 - USB OUTPUT

Output Connector : P1

Description: header 8 way FM 1.0mm pitch
 Manufacturer: JST (or equivalent)
 Part No: 08FM-1.0SP-1.9-TF
 Mating connector: Flexible flat cable (FFC), 1.0mm pitch

Pin Number	PS/2 & USB
1	+5V DC
2	D-, PS/2 Data
3	D+, PS/2 Clock
4	Right Switch
5	Left Switch
6	0V
7	Middle Switch
8	N.C.

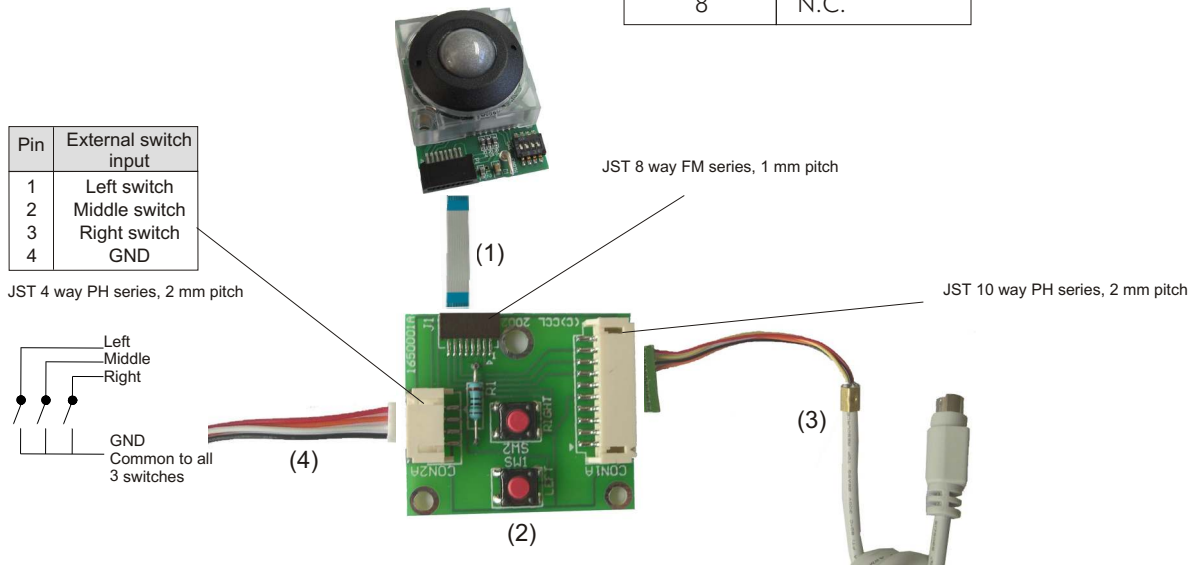

OPTIONAL ASSEMBLIES

Standard lead & PCB assemblies for connection to the X13 unit are available. Other assemblies can also be supplied to customer specifications.

Part Number	Leads / Adapters	Description
1151-00	Flexlead	Flexlead interconnection cable, 12 cm long (1)
T1601126	PCB	Interconnection PCB (2)
OC5010160	Output cable USB	1,6 m shielded cable with USB type A plug (3)
OC6010160	Output cable PS/2	1,6 m shielded cable with 6 pin mini DIN plug (3)
IC040035	Switch Input	4 way JST style - bare wires, 35 cm long (4)

13 mm LASER TRACKBALL

CONFIGURATION

The X13 Series trackball provides features that may be selected using the DIP switch located on the printed circuit board. This table details the assigned function of each switch.

DIP Switch Functions

DIP Switch	Function	OFF	ON
1	Orientation 1 Setting	See Figure.1	See Figure.1
2	Orientation 2 Setting	See Figure.1	See Figure.1
3	Factory setting	N/A	N/A
4	Not used	N/A	N/A

Factory default setting: All DIP switches OFF

Orientation

The orientation function allows the user to mount the X13 Series trackball device in one of four positions (see figure. 1 below). The orientation of the device is determined by the direction in which the output connector is facing (when viewed from the top of Trackerball device). The Tracker ball orientation can be selected to accommodate customer requirements for connector location and wiring.

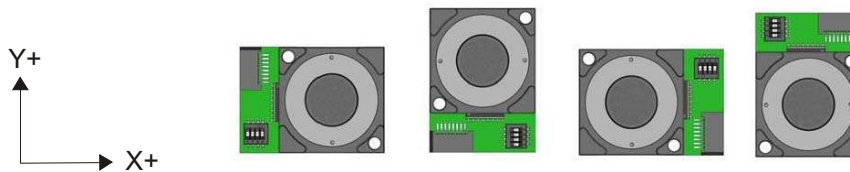

Switch 1	Orientation 1	Off	On	Off	On
Switch 2	Orientation 2	Off	Off	On	On

Figure.1 Mounting Orientations

ORDER INFO

OUTPUT	DAMPER RING	RUBBER SEAL
Quadrature	X13-70021D	X13-70022D
PS/2 & USB	X13-76021D	X13-76022D

MANUFACTURER

Cursor Controls Ltd, Brunel Drive,
Newark, U.K
Tel: ++44 (0) 1636 615600
Fax: ++44 (0) 1636 615601
Website : www.cursorcontrols.com
E-mail: sales@cursorcontrols.com



EUROPEAN SALES & SERVICE CENTER

NSI bvba, Haakstraat 1A,
B-3740 Bilzen, Belgium
Tel. : +32 89 51 90 00
Fax : +32 89 91 90 09
Website : www.nsi-be.com
E-mail : info@nsi-be.com

