

REV.	RIF.	DESCR. MODIFICA	DATA	AUTORE
1		Packaging according to "IPC/JEDEC J-STD-033A"	17-05-11	Biasio
2		The carrier-tape wide was w=32mm. The carrier pitch was 20mm. The nr. of pieces/reel was 192. The nr. of reel/box was 6.	26-10-11	Biasio

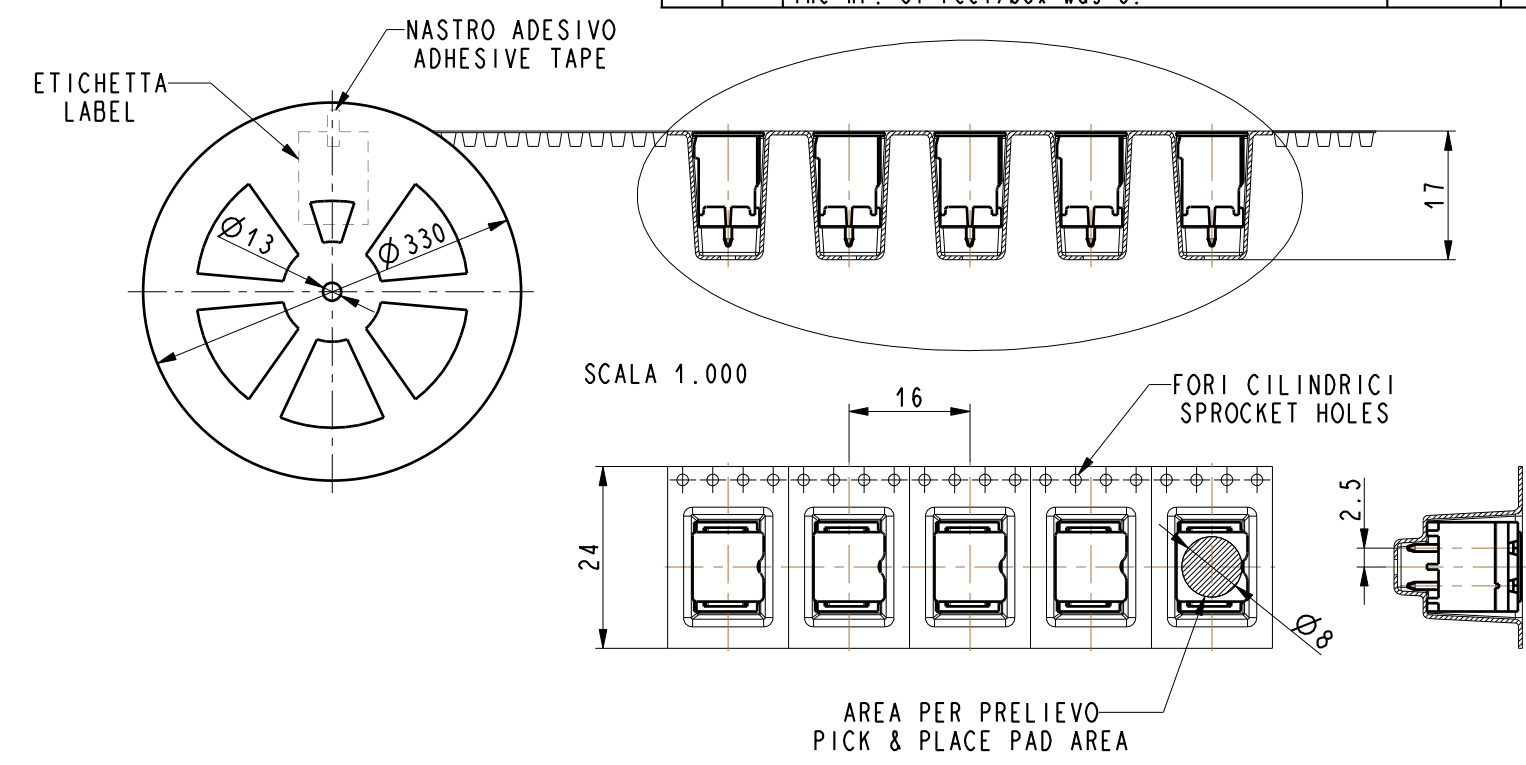

MAX 7 BOBINE/SCATOLONE
MAXIMUM 7 REELS/BOX

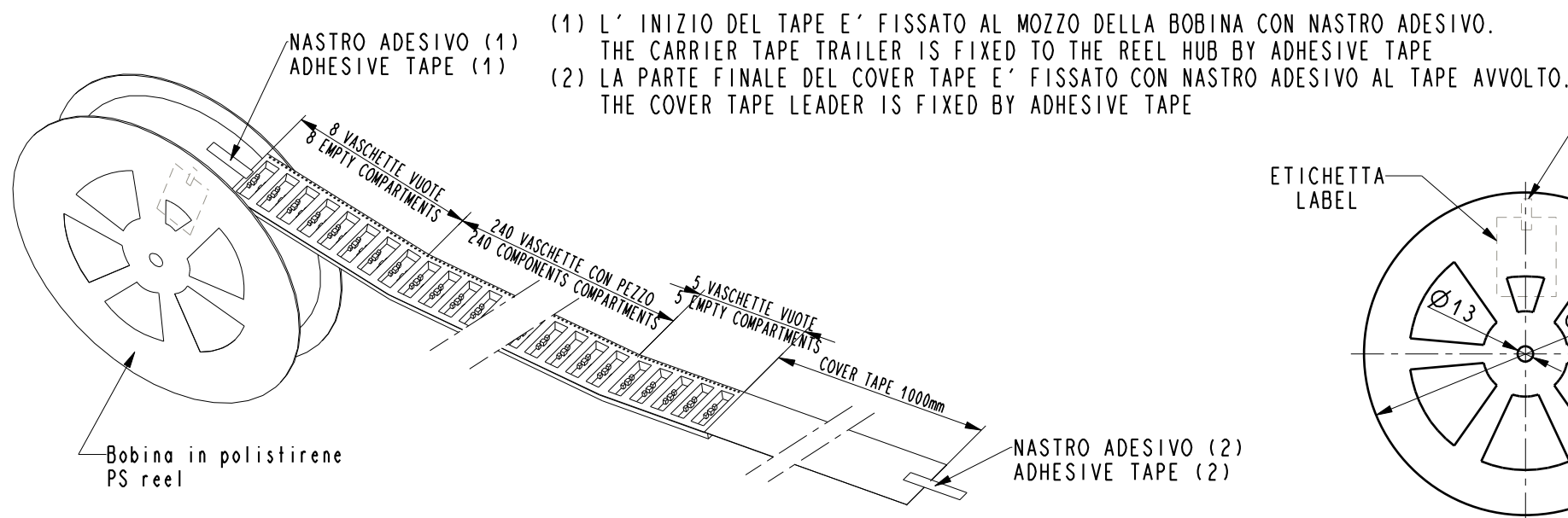
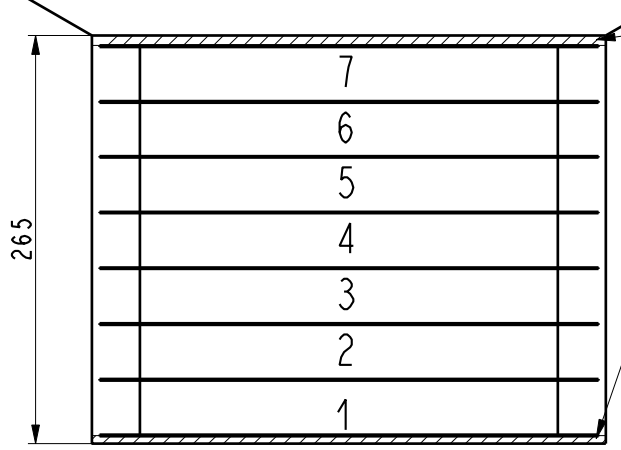

MATERIALE DI RIEMPIMENTO
FILLER PACKAGING MATERIAL

**NOTE PER REPARTO PRODUZIONE SAURO
NOTES FOR SAURO' PRODUCTION DEPT.**

-L'operazione di sigillatura nel sacchetto deve essere svolta entro 4 ore dall'operazione di essiccazione da effettuarsi a 120°C per 4 ore.

Composizione dell'imballo - (Packaging bill materials)		
Codice - P/N	Descrizione - Description	Note - Remarks
W10081-TV	Scatolone (Carton box)	
W10130-NY	Sacchetto a barriera d'umidità (Moisture barrier bag)	Da sigillare a caldo sotto vuoto (Vacuum hot sealed)
W10132-IU	Indicatore livello di umidità (Humidity indicator)	1 pezzo in ogni sacchetto 1 piece per bag
W10131-AD	Sacchetto argilla disidratante (Desiccant bag)	2 pezzi in ogni sacchetto 2 pieces per bag
V20-00-002	Foglio informativo Moisture-Sensitive-Devices (Moisture-Sensitive-Devices information)	Da inserire in ogni sacchetto con le scritte in vista. (Inside each bag)
W10140-FL W10141-FL	Bobina in polistirene D=330mm; L=24mm (PS reel D=330mm; W=24mm)	
W1CIM24D1-01	Carrier Tape	Rif. disegno S19-00-128
W100CT-24D	Cover Tape	
-	Etichetta (Label)	Da applicare sulla bobina (Applied on the reel)

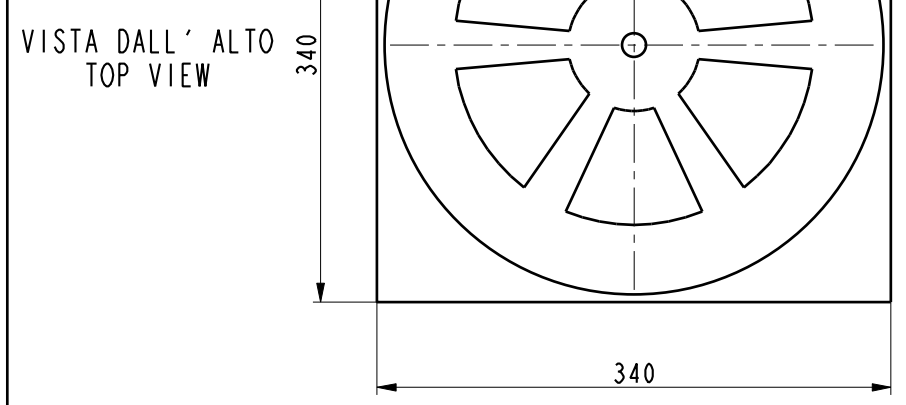
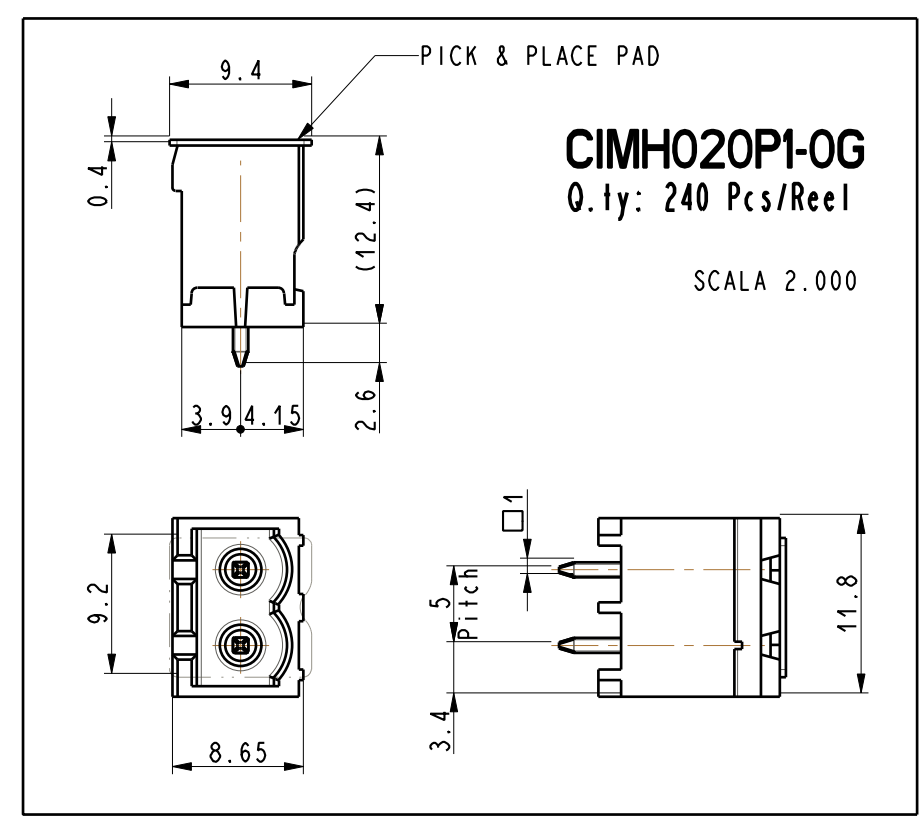

CODICE PN

KC IMH020P1 TG

REVISIONE: KIT: KC IMH020P1TG PASSO/PITCH: -

FOGLIO: 1/2 DIS.N°: KC IMH020P1TG FIRMA: Biasio DATA: 20-May-10