

COMe-cAL6 (E2)

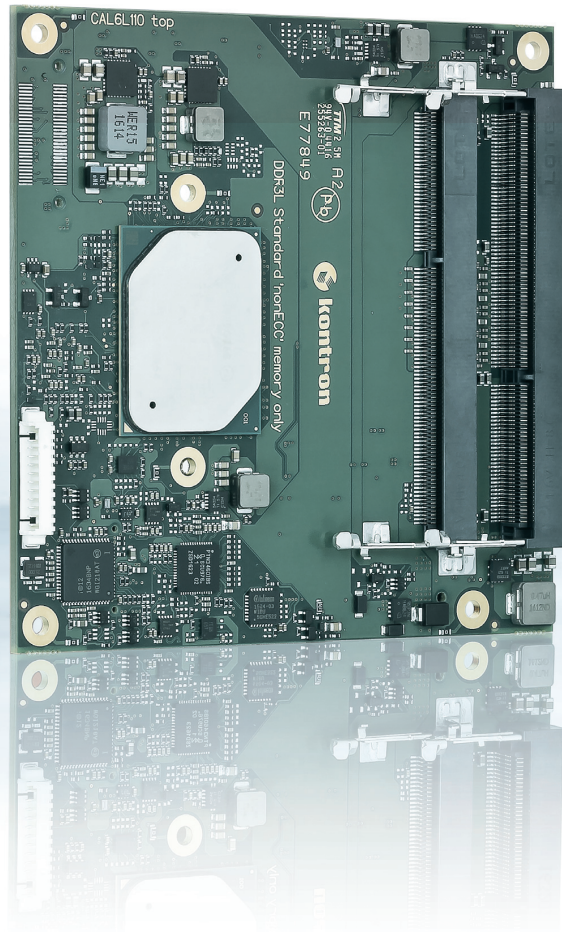

COM Express® COMPACT TYPE 6 WITH Intel® Atom™ E3900 Series, Pentium® AND Celeron® PROCESSORS

- ▶ Low-power – performance/watt optimized form factor solution
- ▶ Up to 8 GByte DDR3L 1600 / 1866 Memory (2x SODIMM socket)
- ▶ 4x USB 3.0/2.0, 4x USB 2.0, 2x SATA, eMMC Flash
- ▶ Industrial grade temperature
- ▶ Support of Kontron's Embedded Security Solution - APPROTECT (optional)

POSSIBILITIES START HERE



► TECHNICAL INFORMATION

COMPLIANCE	COM Express® compact, Pin-out Type 6																
DIMENSIONS (W X D)	95 x 95 mm																
CPU	Intel® Atom™ x7-E3950, 4C, 1.6 / 2.0 GHz, 12 W TDP Intel® Atom™ x5-E3940, 4C, 1.6 / 1.8 GHz, 9.5 W TDP Intel® Atom™ x5-E3930, 2C, 1.3 / 1.8 GHz, 6.5 W TDP Intel® Pentium® N4200, 4C, 1.1 / 2.5 GHz, 6 W TDP Intel® Celeron® N3350, 2C, 1.1 / 2.4 GHz, 6 W TDP																
CHIPSET	-																
MAIN MEMORY	2x SODIMM for DDR3L-1600/1866 (non ECC) up to 8 GByte																
GRAPHICS CONTROLLER	Intel HD Gfx Gen9: 1x LVDS/eDP (3840 x 2160 @ 60 Hz) 2x DP (++) on DDI1/DDI2 up to 4K																
ETHERNET CONTROLLER	Intel® I210IT / I211AT																
ETHERNET	10/100/1000 MBit Ethernet																
HARD DISK	2x SATA 6Gb/s, SDIO Interface (shared with GPIO)																
FLASH ONBOARD	32 GByte eMMC SLC on request: - up to 64 GByte eMMC SLC - up to 128 GByte eMMC MLC																
PCI EXPRESS® SUPPORT	<table border="1"> <tr> <td></td> <td>LAN</td> <td>PCIe switch</td> <td>PCIe config</td> </tr> <tr> <td>default</td> <td>yes</td> <td>no</td> <td>3x PCIe x1</td> </tr> <tr> <td>on request</td> <td>yes</td> <td>yes</td> <td>5x PCIe x1 or 1x PCIe x2 + 3x PCIe x1</td> </tr> <tr> <td>on request</td> <td>no</td> <td>no</td> <td>2x PCIe x2 or 4x PCIe x1</td> </tr> </table>		LAN	PCIe switch	PCIe config	default	yes	no	3x PCIe x1	on request	yes	yes	5x PCIe x1 or 1x PCIe x2 + 3x PCIe x1	on request	no	no	2x PCIe x2 or 4x PCIe x1
	LAN	PCIe switch	PCIe config														
default	yes	no	3x PCIe x1														
on request	yes	yes	5x PCIe x1 or 1x PCIe x2 + 3x PCIe x1														
on request	no	no	2x PCIe x2 or 4x PCIe x1														
PANEL SIGNAL	DDI 1/2: DP++, LVDS: Single Channel 18/24 bit or eDP on request)																
USB	4x USB 3.0/2.0, 4x USB 2.0 (3x USB 2.0 w Security Chip)																
SERIAL	2x serial interface (RX/TX only)																
AUDIO	Intel® High Definition Audio																
COMMON FEATURES	SPI, LPC, SMB, Fast I ² C, Staged Watchdog, RTC																
BIOS	AMI Aptio V																
HUMIDITY	93 % relative Humidity at 40 °C, non-condensing (according to IEC 60068-2-78)																
FEATURES ON REQUEST	PCIe configurations w/ PCI hub and w/o LAN chip Security Chip (Support of Kontron APPROTECT) eMMC Flash configuration eDP instead of LVDS General Purpose SPI instead of Boot SPI FSP + Coreboot, AES-NI, USB client																
POWER MANAGEMENT	ACPI 4.0																
POWER SUPPLY	8.5 V – 20 V Wide Range, Single Supply Power																
SPECIAL FEATURES	POSCAP capacitors, Trusted Platform Module TPM 2.0, microSD card socket 4k Resolutions, GPIO/SDIO Switch, Industrial grade temperature																
OPERATING SYSTEM	Windows® 10, Enterprise, Windows 10 IoT, Linux, VxWorks 7.x																
TEMPERATURE	COMe-cAL6 - commercial temperature: 0 °C to +60 °C operating, -30 °C to +85 °C non-operating COMe-cAL6 E2 - industrial temperature: -40 °C to +85 °C operating, -40 °C to +85 °C non-operating																
SUPPORTED MODULES	COMe-cAL6 / COMe-cAL6 E2																

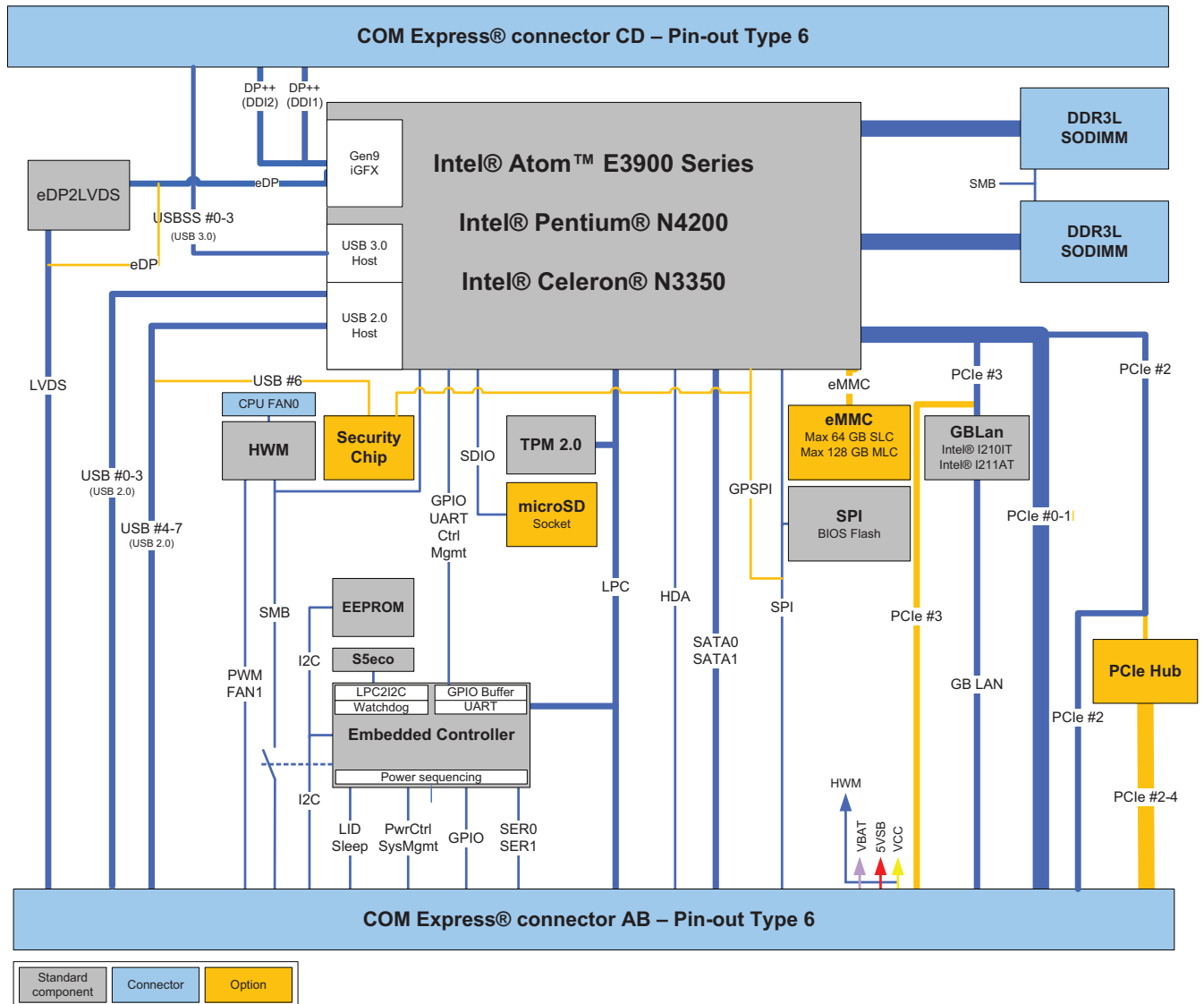

Copyright © 2017 Kontron AG. All rights reserved. All data is for information purposes only and not guaranteed for legal purposes. Information has been carefully checked and is believed to be accurate; however, no responsibility is assumed for inaccuracies. Kontron and the Kontron logo and all other trademarks or registered trademarks are the property of their respective owners and are recognized. Specifications are subject to change without notice. CONIR-CALD-20170612-WMH1

► CORPORATE OFFICES

EUROPE, MIDDLE EAST & AFRICA

Lise-Meitner-Str. 3-5
86156 Augsburg
Germany
Tel.: + 49 821 4086 0
Fax: + 49 821 4086 111
info@kontron.com

NORTH AMERICA

14118 Stowe Drive
Poway, CA 92064-7147
USA
Tel.: + 1 888 294 4558
Fax: + 1 858 677 0898
info@us.kontron.com

ASIA PACIFIC

1-2F, 10 Building, No. 8 Liangshuihe 2nd Street,
Economical & Technological Development Zone,
Beijing, 100176, P.R.China
Tel.: +86 10 63751188
Fax: +86 10 83682438
info@kontron.cn